

# Mining Truck

# T 282 C

Gross Vehicle Weight (GVW): 600 t / 661 ton  
Payload Class: 363 t / 400 ton  
Empty Vehicle Weight (EVW): 237 t / 261 ton



Preliminary

# LIEBHERR

# T 282 C

Gross Vehicle Weight (GVW): 600 t / 661 ton  
Payload Class: 363 t / 400 ton  
Empty Vehicle Weight (EVW): 237 t / 261 ton





## **Productivity**

The Liebherr T 282 C mining truck combines a high horsepower diesel engine with an efficient AC drive system to maximize productivity and minimize fuel consumption.

## **Reliability**

The T 282 C is engineered to be strong, durable, and lightweight. This mining truck enables reduced cycle times and offers the highest payload to empty vehicle weight (EVW) ratio in its class.

## **Safety**

Liebherr promotes a safe, healthy, and incident-free work environment for both product and personnel.

## **Low Operating Cost**

Hauling more for less is Liebherr's trademark to achieve maximum profitability. Liebherr allows for higher output at a lower operating cost by offering durable, yet lighter equipment.

## **Customer Support**

Liebherr provides customers with a complete range of services that deliver the lowest cost of ownership. The company implements the right combination of scheduled, preventative, and planned maintenance to allow customers to achieve availability goals.

## **Vertical Integration**

Liebherr is synonymous with quality products. The new T 282 C mining truck offers optimum reliability and availability.

This 363 t / 400 ton truck utilizes the most current technologies in components and software to minimize the overall cost of ownership.



The T 282 C is a Liebherr integrated truck. The company incorporates proprietary components in strategic areas, specifically developed to serve the needs of the mining industry. The vertical integration philosophy advances supply chain coordination and facilitates the allocation of resources according to customer needs.



**IGBT Control Box**

The IGBT technology offers numerous advantages for high power applications. It optimizes the performance and efficiency of the truck, while increasing reliability.



**Front Wheels**

Designed to work in conjunction with the front suspensions, the front wheels offer superior maneuverability and reduced tire wear.



**Front Suspensions**

The T 282 C features “Double A-Frame” front suspensions. This concept provides longer vertical wheel travel and less strut travel, resulting in shorter suspension struts. The “Double A-Frame” design contributes to the reduction of operating costs by increasing tire life. The suspension design eliminates side loading on the struts allowing immediate and accurate payload monitoring.



**Frame**

Welded steel structure with cast components in strategic areas:

- Designed according to international Institute of Welding (IIW) fatigue guidelines
- Hollow box rails with fully welded internal structure
- Critical welds ultrasonically inspected based on American Welding Society (AWS) D1.1
- Lightweight design supports low empty vehicle weight

# Vertical Integration



## Rear suspension

The quality of design attenuates loading impact and improves ride with a 20 % longer stroke and 33 % reduction in internal pressure.

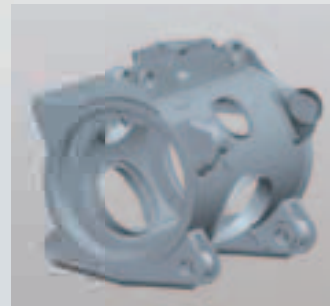

## Axle box

Optimized vents offer great cooling capabilities. The orientation of the drag link pins extends component life by preventing debris accumulation.

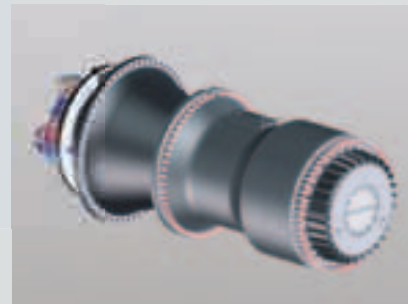

## Planetary Gear Sets

The planetary gear sets have been utilized on Liebherr trucks since 2004. This proven system has performed in a variety of applications. Its efficient design maximizes the energy transmitted into torque and reduces mechanical losses inside the gearbox.



## Traction motors

The AC traction motors have been specifically designed for mining applications to provide the highest truck reliability.

nts in  
titude of  
al stiffeners  
ased on





**Litronic Plus Traction Motors and Planetary Gears**

The traction motors deliver up to 4.474 kW or 6,000 hp. Reduced pressure drops across the motors enhance their cooling capabilities for operation at higher altitudes or at higher ambient temperatures. Multiple gear ratios are available to optimize performance for specific mining applications.

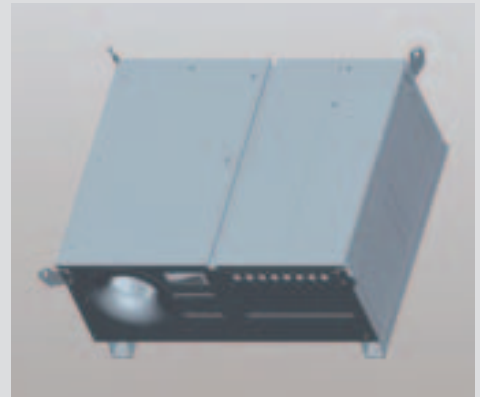

# Productivity

The Liebherr T 282 C mining truck combines a high horsepower diesel engine with an efficient Litronic Plus AC drive system to maximize productivity and minimize fuel consumption.

Main components:

- Diesel engine
- Traction alternator
- Litronic Plus control box with integrated rectifier and main blower
- Litronic Plus traction motors and planetary gears
- Litronic Plus grid box

## Diesel Engine

The standard engine has two available configurations: fuel optimized and emission optimized (complying with latest emission standards).

The efficient triple injection monitoring system on the standard engine allows CAN Bus interface for the monitoring of fuel consumption and multiple exhaust gas temperatures.

As a safer “wet” engine, the diesel engine includes a water-jacketed exhaust manifold and turbo system designed to reduce engine surface temperatures below the auto-ignition point of diesel and hydraulic fluid.

Other engine options are available.

## Traction Alternator

The traction alternator is matched to the fitted engine to provide the required power output.

## Litronic Plus Control Box with Integrated Rectifier and Main Blower

The control box consists of two power stacks per motor providing three-phase AC current to each traction motor. The control box is liquid-cooled. It outperforms air-cooled circuits in warmer climates and higher altitudes due to its greater cooling capability.

The rectifier is located inside the pressurized control box protected from water and dust. The main blower is engine speed independent and controlled by a liquid-cooled inverter positioned in the control box. The noise and energy expended by the blower is limited to what is needed for immediate cooling purposes. The efficiency of the blower reduces fuel consumption and increases reliability.

### Litronic Plus Grid Box

The horizontal orientation of the AC blower motor provides better accessibility and increases airflow.

This motor is powered by a liquid-cooled inverter located inside the Litronic Plus control box.

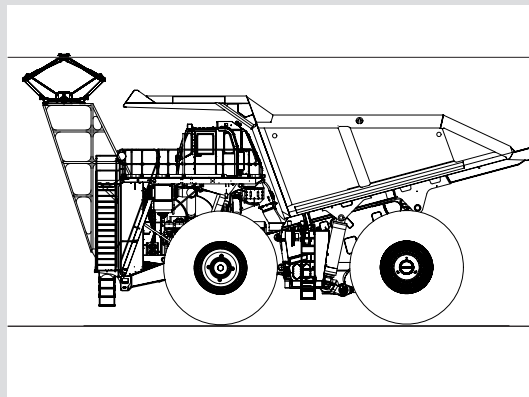

### Trolley Capable

A package is available upon request. Consult factory for additional details.





Outside  
Temperature

Cab  
Temperature



≈ 50°C  
122°F



≈ 25°C  
77°F



≈ -40°C  
-40°F



≈ 15°C  
59°F

### Climate Control

Liebherr automatic climate control provides a comfortable environment for operators:

- Internal cab temperature of 25° C (77° F) can be maintained under a maximum ambient temperature of 50° C (122° F)
- Internal cab temperature of 15° C (59° F) can be maintained under a minimum ambient temperature of -40° C (-40° F)

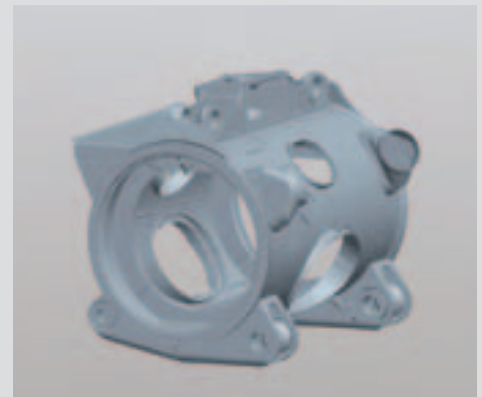



# Reliability

The Liebherr T 282 C is engineered to be strong, durable, and lightweight. This mining truck enables reduced cycle times and offers the highest payload to empty vehicle weight (EVW) ratio in its class.

## Litronic Plus IGBT Drive System

The IGBT drive system provides a smoother voltage variation which reduces power losses in heat. The reliability of the drive system is enhanced with the use of fewer electrical parts. The unique gate sequencing of the grid box allows an even wear of the grid resistors.

## Diagnostics

The Litronic Plus Diagnostics system integrates all vital truck components. Engine, drive, and truck diagnostics can be accessed via a single USB or Ethernet “OPC” port. A data storage system is included and can be used for advanced diagnostics. The stored data is accessible through Wi-Fi or remotely via cellular and Low Earth Orbit (LEO) satellites.

A 12-inch color touch screen is provided in the cab for the display of critical systems data, fault codes, and startup sequences. The Litronic Plus Diagnostics program detects the exact cause of each fault for greater maintainability.

The Liebherr T 282 C utilizes CAN open operator gauges instead of digital displays. In the event of individual non-vital gauge replacement, the truck is able to continue its operation until service is completed.

Additional space and mounting brackets are available to accommodate optional equipment, such as: dispatch systems, rearview monitor, and two-way radio.

### Accessibility

- Dual access to axle box via service and maintenance doors
- AC grid box blower motor accessible from the deck
- Easy access to both sides of engine and alternator
- Centralized service station conveniently located at ground level
- Sampling points located at or near ground level

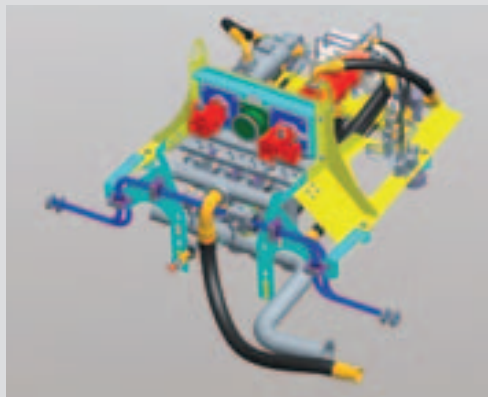

### Serviceability and Maintainability

- Individually routed fixed piping reducing the length and number of hydraulic hoses
- Single access point for all vital truck systems via in-dash color touch screen
- Litronic Plus Diagnostics
- Lighter components
- Multiple tie off points



### Brake Blending

■ Dynamic Braking\*     
 ■ Service Brakes\*\*

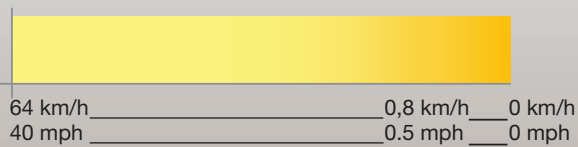

\* Dynamic braking from 64 km/h (40 mph) to 0 km/h (0 mph)

\*\* Service brake blending begins at 0,8 km/h (0.5 mph)

### Brake Blending

The Litronic Plus IGBT AC drive system utilizes dynamic braking to bring the T 282 C to an almost complete standstill of 0,8 km/h (0.5 mph).

The brake blending system automatically applies the hydraulic dry disc service brakes to bring the truck to a complete stop.



# Safety

Liebherr promotes a safe, healthy, and incident-free work environment for both product and personnel.

## Operator Cab

The ergonomically designed wide cab offers functionality, visibility, and comfort to the operator. The cab complies with all operator seat vibration and noise exposure standards: vibration ISO 2631 and noise ISO 6394.

Visual and audible alarms are activated when the operator door is opened and the parking brake is not applied.

Increased operator protection is achieved with the addition of a safety plate underneath the cab. The cab design includes an ISO 3471 compliant integrated ROPS.

## Braking System

The braking of the truck is performed by dynamic braking. The system is virtually wear-free, resulting in less replacement parts.

The emergency braking is performed by hydraulic dry disc brakes. The hydraulic braking system is split into two separate circuits for front and rear with independent accumulators for each circuit. The system complies with ISO 3450 braking standard. A separate pedal for the service brake is provided for emergency situations.

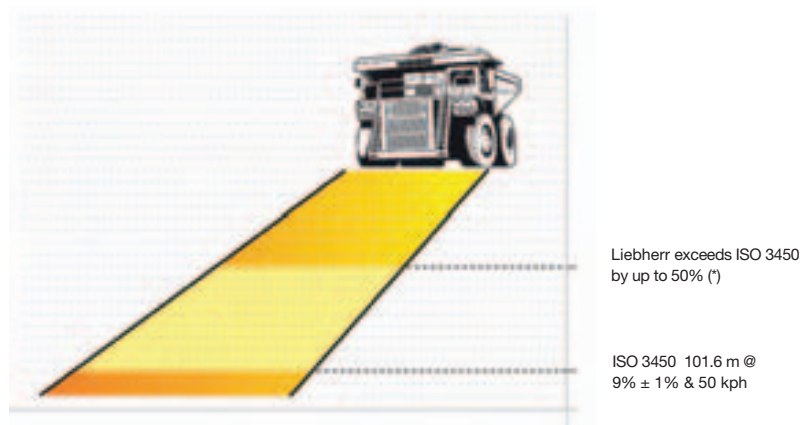

(\*) Service brakes and dynamic braking - actual performance depends on specific conditions such as ground adhesion and truck speed

## Slip-Slide Control

The Litronic Plus IGBT drive system offers highly advanced slip-slide control. It utilizes a front wheel speed sensor that prevents lock up of rear wheels and allows for reliable dry disc brake blending.



## Park Brake

The spring applied / pressure released park brake is capable of holding a 100% loaded truck on a ± 15% grade.

## Speed Control

Speed limits can be set for loaded, unloaded, and dump body up conditions. These include mine-determined speed limits, which are independent of operator input. Dynamic braking speed control is available for downhill operation. It allows the use of operator-set limits to maintain a safe operation.

## Anti-Rollback

The anti-rollback function automatically applies the service brakes in forward or reverse when zero speed is required on an incline.



**Frame**

Liebherr load-management design philosophy increases durability and minimizes Empty Vehicle Weight (EVW). Low EVW is primarily achieved by utilizing castings only in high stress areas of the frame, such as the integrated hoist carriage, cross member, and dump body pivot.

■ Castings in high stress areas

**Cost Effectiveness of Braking Systems**

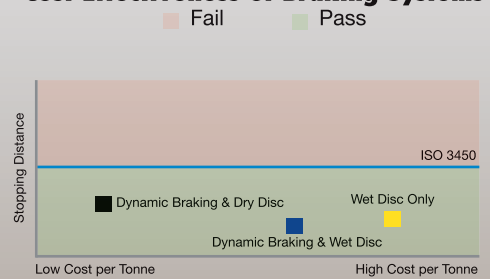



# Low Operating Cost

Hauling more for less is Liebherr's trademark to achieve maximum profitability. Liebherr allows for higher output at a lower operating cost by offering durable, yet lighter equipment.

## Less Fuel Consumption

The T 282 C is a fuel efficient truck. Its AC drive system is coupled with a traction alternator powered by a high horsepower engine. The drive system provides continuous acceleration and dynamic braking without shifting gears.

By incorporating an efficient load management, the T 282 C requires less operating hours to meet production targets. As a consequence, associated costs are minimized, such as: fuel, tires, labor, spare parts, lubricants and maintenance. The chart below illustrates the operating hours and fuel required of two leading competitors to equal the production seen of the T 282 C at 60,000 hours.

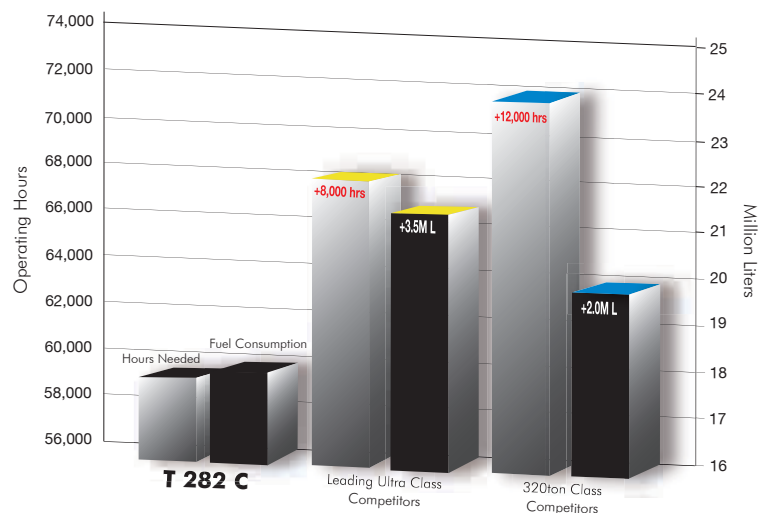

## Low Empty Vehicle Weight (EVW)

The new Litronic Plus AC drive system weighs less than both mechanical drive systems and old versions of AC drives. It requires the use of lighter components, which reduces the EVW.

The T 282 C innovative "Stress Flow" design requires lighter steel structures and castings, than other conventional truck frames, while maintaining durability.

### Cost Effectiveness of Dry vs. Wet Brake Systems

The T 282 C utilizes dynamic braking. Dry disc brakes are available for emergency situations. The air-cooled dry disc brakes do not require additional oil, pumps, filters, and cooling circuits to operate. Liebherr braking systems comply with ISO 3450 standard and offer the lowest cost per tonne.



### Differential Wheel Torque Control

When traveling through a curve, the drive system will automatically adjust the torque of the rear traction motors in order to maximize traction and minimize tire wear during low speed handling.



#### On-Site Support

Liebherr provides on-site service support, as well as training for customer's maintenance groups. Training classes can be customized to suit specific needs.

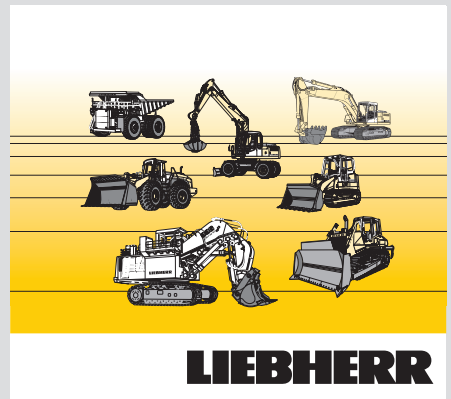



# Customer Support

Liebherr provides customers with a complete range of services that deliver the lowest cost of ownership. The company implements the right combination of scheduled, preventative, and planned maintenance to allow customers to achieve availability goals.

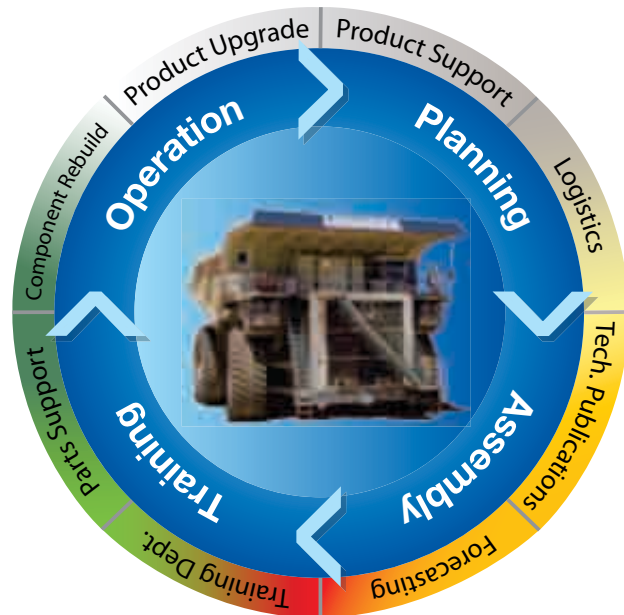

## Product Support

Liebherr product support provides the vital interface between the customer and Liebherr. There are different levels of product support available:

- Assembly
- Maintenance Advice
- Troubleshooting Assistance
- Technical Expertise

Product support personnel work with customers from the assembly of a truck throughout its operating life. Liebherr understands the importance of proper service and support, and will be there for the life of the equipment.

### Technical Publications

The technical publications department offers both printed and online manuals. Additional options are available for online manuals.



### On-Line Support

A LinkOne user-friendly, accurate, and complete electronic parts catalog gives customers access to the original configuration of the truck. This publication viewing system makes information available to assist customers with finding the right part, the first time, every time.



#### Performance Indicators

- Liebherr provides key performance indicators (KPIs) to communicate truck fleet performance
- The KPIs are customized to site requirements



# Customer Support

## Operator and Field Service Technician Training

The training program consists of a three-level competency-based blended training.

Level 1 - General web-based technical skills training

Level 2 - Product-specific web-based technical training

Level 3 - Product-specific hands-on troubleshooting technical training

Advantages of Liebherr's technical training strategy:

- Customer focused 24/7 access to technical training (just-in-time training)
- Minimizes employee time off the job
- Maximizes effectiveness of classroom training time
- Reduces customer's overall training costs
- Provides customers with mechanism for recording and tracking employee training

## Parts Support and Logistics

The proactive forecasting for global fleet requirements optimizes inventories and logistics to ensure prompt response to any parts requirements:

- Continuous two-year forecasting
- 24/7 on-call service
- Inventory planning and management
- Global and real-time inventory data tracking system

## Component Rebuild Program

Condition-based monitoring maximizes major component life while avoiding unplanned failures. Rebuilds are conducted by certified repair shops using best practices, ensuring that the life and reliability of rebuilt components match new component performance expectations.

## Product Upgrade Programs

The operating life of the Liebherr T 282 C can be extended and optimized by upgrading any of its systems or components as advances in technology, innovations in design, and improvements in manufacturing techniques occur.



### Forecasting Tool

- Continually updates the estimated life of a major component based on algorithm analyses of hours at the time of replacement
- Provides accurate forecasted life to ensure that a major component's spare is available when needed
- Inventory planning takes in consideration the spare parts needed for scheduled maintenance and component rebuild projects

# Technical Data



## Engine

<b>Model</b> _____	<b>MTU DD 20V4000 Tier II</b>
Gross horsepower @ 1,800 rpm _____	2.800 kW / 3,750 hp
No. of cylinders _____	20
Displacement _____	95,4 L / 5,822 in <sup>3</sup>
Wet weight _____	12.020 kg / 26,500 lbs
Crankcase _____	335 L / 88 gal
Cooling system _____	758 L / 200 gal
<b>Model</b> _____	<b>Cummins QSK 78</b>
Gross horsepower @ 1,900 rpm _____	2.610 kW / 3,500 hp
No. of cylinders _____	18
Displacement _____	78 L / 4,735 in <sup>3</sup>
Wet weight _____	11.300 kg / 24,912 lbs
Crankcase _____	295 L / 78 gal
Cooling system _____	721 L / 191 gal
Fan clutch (optional) _____	Variable speed, temperature controlled
Air cleaners _____	Two units with 2 elements per unit with electronic restriction monitoring in the cab
Radiator _____	Mesabi
Starter _____	Electric
Roll out power module _____	Radiator, engine and alternator, mounted on roll out sub frame
Batteries _____	6 x 12 Volt, (3 series of 2), 1,200 CCA each at -18° C (0° F), 1,475 CCA at 0° C (32° F)



## Electric Drive System

Manufacturer _____	Liebherr - Litronic Plus AC Drive System (IGBT)
Traction alternator _____	AC brushless, direct drive
Traction motors _____	Litronic Plus AC Induction Motors (2)
Gear ratio _____	Standard 43.7 to 1 - haul profile dependant Optional 37.33 to 1 - haul profile dependant
Max speed _____	Standard 54 km/h / 34 mph Optional 64 km/h / 40 mph
Cooling fan _____	Electric cooling motor with twin impeller radial fan (75 kW / 100 hp)



## Tires

Rims _____	41" x 63" bolt on rims
Tires _____	Michelin 56/80 R63 or Bridgestone 59/80 R63



## Suspensions

Front suspension _____	Double A-frame with inclined king pin design pivot and spindle
Rear suspension _____	Three bar linkage comprised of triangular upper link plus two bottom drag links
Suspension struts _____	Nitrogen over oil with integral damping



## Braking Systems

Electric dynamic braking with continuous rating, fan forced air over stainless steel resistor grids with a dry disc emergency braking system.	
Electric dynamic braking _____	Max: 4.480 kW / 6,030 hp
Extended speed range _____	Full dynamic braking down to 0,8 km/h / 0.5 mph. Automatic brake blending with service brakes down to zero
Dynamic braking speed control _____	Operator adjustable and will automatically slow the truck on downhill grade
Two speed over speed _____	Automatic speed settings for empty and loaded truck adjustable for site requirements
Slip slide traction control _____	Computer controlled, propel and dynamic braking, forward and reverse, fully independent left and right
Service brakes front _____	Single disc, wheel speed, five calipers per wheel
Service brakes rear _____	Dual discs per side, one caliper per disc, armature speed
Hydraulic accumulators _____	2 x 7,6 L / 2 gal, separate accumulator for front and rear axle
Park brakes _____	Spring applied, pressure released, one caliper per each rear disc
Filtration _____	Cleanliness level ISO 18/16/13



## Steering

Ackermann center point lever system. Full hydraulic power steering with accumulator safety backup. Fully separate from dump hydraulic system. Two double acting hydraulic cylinders.

Hydraulic accumulator _____	170 L / 45 gal SAE J53
Filtration _____	Cleanliness level ISO 18/16/13
Turning radius (SAE) – Tire centerline* _____	17,2 m / 56' 5"
Vehicle clearance Radius _____	18,45m / 60' 6"

\* This is a theoretical calculation and depends on the ground surface, the strut length and tie rod length.



## Dump System

Two double stage, double acting hoist cylinders with inter stage and end cushioning in both directions. Electronic joystick with full modulating control in both extend and retract.

Dump angle _____	49° (45° with optional kick-out switch)
Cycle times _____	< 50 seconds
Remote dump _____	Quick disconnects for external power dumping (buddy dump) accessible from ground level
Filtration _____	High pressure filtration and return line filtration. Cleanliness level ISO 18/16/13



## Body

Body sizes are custom designed to fit customer requirements and specific applications.



# Technical Data



## Frame

Design \_\_\_\_\_ Closed box structure with multiple torque tube cross members, internal stiffeners and integrated front bumper. Steel castings are used in high stress areas.

Welding \_\_\_\_\_ Frame girders welded inside and out with ultrasonic inspection aligned with AWS D1.1



## Weights

Payload \_\_\_\_\_ 363 t / 400 ton

Gross Vehicle Weight (GVW) \_\_\_\_\_ 600 t / 661 ton

Chassis weight \* \_\_\_\_\_ 194 t / 214 ton

Body weight \_\_\_\_\_ Custom for each mine site

Frame capacity \*\* \_\_\_\_\_ 406 t / 447 ton

Weight distribution \_\_\_\_\_ Empty – front 46 % / rear 54 %  
Loaded – front 33 % / rear 67 %

\* depends on options fitted

\*\* total weight of body and payload, subject to chassis weight



## Cab

Deluxe cab with integrated ROPS and double wall design for optimum insulation. Fully adjustable air suspension operator seat with double lumbar support and full size second seat for training requirements. Operator comfort controls include a tilt and telescoping steering wheel, heater, defroster and standard AC. Real-time vital truck information is easily displayed to the operator and also recorded for download.



## Sound

Designed to meet ISO, OSHA and MSHA occupational noise criteria for truck operator weighted sound exposure.



## Fluid Capacities

Fuel tank \_\_\_\_\_ 6813 L / 1800 gal

Hydraulic dump circuit

- Tank \_\_\_\_\_ 1.302 L / 344 gal
- System \_\_\_\_\_ 1.514 L / 400 gal

Hydraulic brake and steering

- Tank \_\_\_\_\_ 924 L / 244 gal
- System \_\_\_\_\_ 1.060 L / 280 gal

Planetary gear sets, each (2) \_\_\_\_\_ 280 L / 74 gal

Front wheels, each (2) \_\_\_\_\_ 60 L / 16 gal

Grease tank \_\_\_\_\_ 90 kg / 200 lbs



## Dimensions

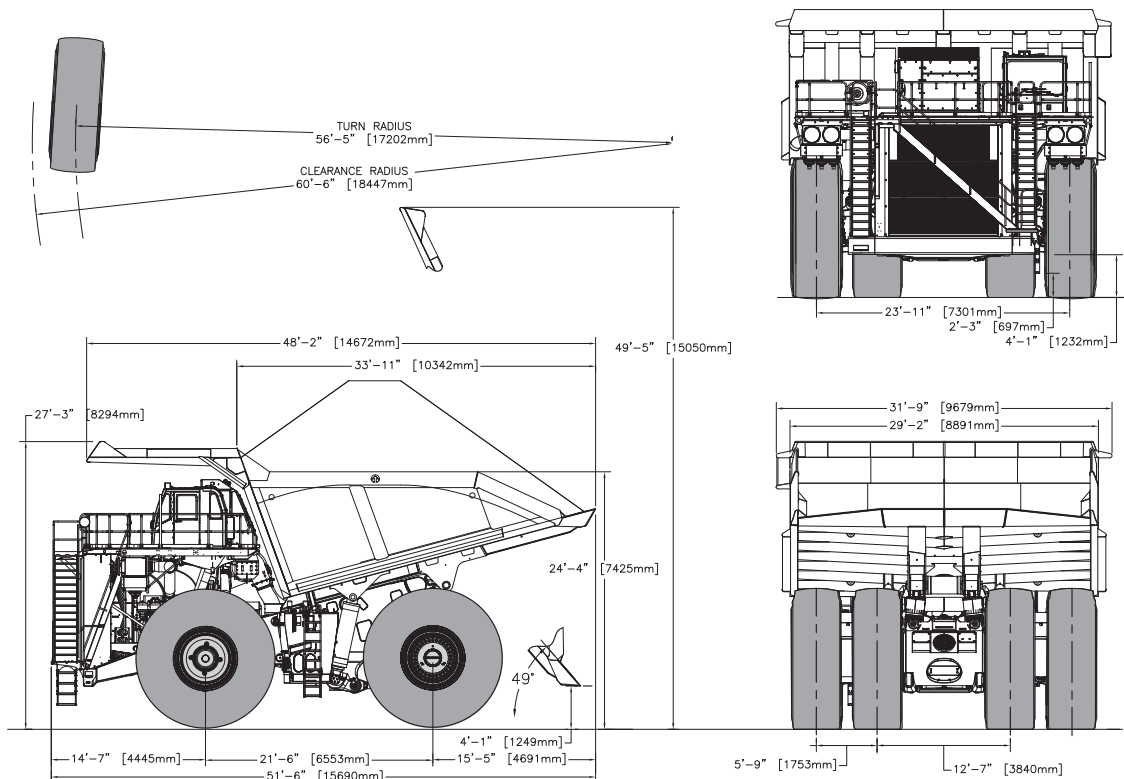

Note: All measurements assuming unloaded using 56/80R63 tires. Loading height dependant on final dump body design

# Standard Equipment



## Standard Equipment

- Access ladders - 45° diagonal stair (drivers side access) with two side ladders with flexible step
- Access lights - 3 x ladder, 1 x superstructure
- Accumulators - 1 x steering 170 L / 45 gal.  
2 x brakes 7,6 L / 2 gal (split front & rear brake system)
- Air cleaner dust ejectors - automatic
- Air cleaner indicators
- Anti-roll back - in forward and reverse
- Axle box - dual entry service access and rear air exhaust
- Batteries - 6 x 12 V wired in series / parallel
- Battery box lockouts - ground level, battery, propel and starter
- Brake warning lights (cab mounted) - dynamic brake and service brake (LED)
- Brakes - dynamic braking with automatic hydraulic brake blending and emergency hydraulic service brakes
- Catwalk - right and left side of engine
- Centralized service station - ground level, driver side, with fuel gauge
- Climate control - combined heater and air conditioner with multiple air ducts and filtered air
- Color - white / grey
- Cup holder - 2 x center consol mounted
- Drive system - liquid-cooled IGBT & grid box control w/ Litronic Plus AC traction motors
- Electric starter
- Electrical system - 24 VDC
- Emergency stops - in-cab and ground level
- Engine fan - low rpm with clutch
- Exhaust - side mounted mufflers with insulated exhaust pipes
- Fire extinguishers - 2 x hand held extinguishers
- Gear ratio - 43.7 to 1
- Grease system - automatic lubrication system
- Grid box - resistor grid control system and variable AC grid box blower motor
- Headlights (HID) - 4 x high beam, 4 x low beam
- Hydraulic coolers - 1 x hoist system, 2 x planetary gear sets gear oil
- Hydraulic filters - high pressure and return line brake, steering and hoist with electronic monitoring
- Mirrors - driver side (flat), off driver side (convex) and access ladder (convex)
- Mud flaps - front and rear of hydraulic and fuel tanks
- Park brake - spring applied pressure release
- Payload display - 2 x superstructure mounted

- Power outlets - 12 VDC and 115 VAC
- Power windows - driver and passenger
- Pressurized cab - with fan on
- Radiator - with header tank level gauge
- Radio ready - wiring, speakers and DIN fitting
- Rear Wheel Drive - Litronic Plus Planetary Gears and Traction Motors
- Recovery points - front and rear
- Recovery system - auxiliary connectors for brake, steering and hoist "buddy system"
- Reverse alarm
- Reverse lights - 2 x axle box, 1 x drivers side superstructure
- Rims - bolt on front and rear
- Rock ejectors - bar type
- ROPS - integrated
- Seat belt - 3 point - 50mm / 2 inch wide
- Seats - fully adjustable driver and passenger seats with air suspension
- Service access ladders - right and left engine bay ladders
- Service lights - 2 x engine bay and 2 x axle box (LED)
- Shut off valves - brake and steering, hoist and fuel tank with electronic monitoring
- Sight gauges - brake, steering, hoist, radiator tanks and front wheel hub
- Steering wheel - tilting and telescopic with center operated horn
- Sun visors - 2 x windshield sun visors and 1 x driver door mounted pull-down blind
- Systems interface - Can Open, Ethernet (OPC), Wi-Fi, USB
- Tie off points - multiple personnel tie off points
- Touch screen - dimmable color touch screen with operator information and warning
- Truck lights - tail, brake, dynamic brake and indicators (LED)
- Windows - tempered and tinted glass
- Windshield - laminated and tinted glass
- Wipers - two speed electric and intermittent with self park and dual wiper arms



# Optional Equipment



## Optional Equipment

- Access ladder - retractable stair
- Accumulators - MDG 15 certified
- Auxiliary low beams (HID) - 2 x bottom radiator mounted
- Battery isolation - double pole with critical system bypass
- Centralized service station - off driver side mounted
- Cold climate - engine heater
- Color - Liebherr yellow/grey
- Cornering lights (HID) - 2 x forward facing superstructure mounted
- Dump body - liners, heated, tailgates, rock deflectors
- Fire suppression system
- Fog lights (HID) - 4 x bottom radiator mounted
- Gear ratio - 37.33 to 1
- High altitude / high cooling package
- Hoist limit - 45° hoist kick out switch
- Protection plates - belly pan, hydraulic tank, steering idler lower grease line
- Reverse light (HID) - off driver side superstructure
- Rims - double gutter bolt on
- Rise topper lights (HID) - 2 x top radiator mounted
- Rock ejectors - chain type
- Service access ladders - Off driver side and driver side engine bay and hydraulic tank ladders with fold up
- Service lights - 2 x rear engine bay (LED)
- Sound attenuation package
- Special language decals
- Trolley capable
- Video cameras and monitors - Off driver side and reverse

Standard and optional equipment subject to change at the discretion of the manufacturer.

Please contact your local representative for further information.

# The Liebherr Group of Companies

## Wide product range

The Liebherr Group is one of the largest construction equipment manufacturers in the world. Liebherr's high-value products and services enjoy a high reputation in many other fields, too. The wide range includes domestic appliances, aerospace and transportation systems, machine tools and maritime cranes.

## Exceptional customer benefit

Every product line provides a complete range of models in many different versions. With both their technical excellence and acknowledged quality, Liebherr products offer a maximum of customer benefits in practical application.

## State-of-the-art technology

To provide consistent, top quality products, Liebherr attaches great importance to each product area, its components and core technologies. Important modules and components are developed and manufactured in-house, for instance the entire drive and control technology for construction equipment and mining trucks.

## Worldwide and independent

Hans Liebherr founded the Liebherr family company in 1949. Since that time, the enterprise has steadily grown to a group of more than 100 companies with over 32,000 employees located on all continents. The corporate headquarters of the Group is Liebherr-International AG in Bulle, Switzerland. The Liebherr family is the sole owner of the company.

[www.liebherr.us](http://www.liebherr.us)



BK-RP LME 1100398-web-08.10

Subject to technical modifications. Illustrations may include optional equipment and accessories.

**Liebherr Mining Equipment Co.**  
4100 Chestnut Avenue, Newport News, VA 23607, USA  
[www.liebherr.us](http://www.liebherr.us), E-Mail: [info.lme@liebherr.com](mailto:info.lme@liebherr.com)

ISO 9001:2000 Certified Firm