



690C EXCAVATOR



Model shown may include options.

ENGINE PERFORMANCE

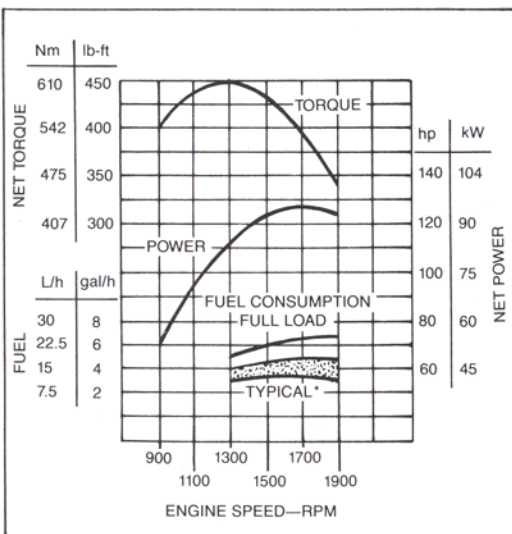

* Depending on operating variables

FEATURES

125-*SAE-net-hp* (93 kW) turbocharged John Deere diesel engine

21-ft. (6.40 m) digging depth

30-ft. (9.14 m) reach at ground level

Two-lever, all-hydraulic pilot control of boom, arm, bucket, and 360-degree continuous swing

Simultaneous operation of digging functions and propel

Track-type undercarriage with hydraulic track adjustment, sealed track chain and metal-faced seals for rollers and idlers

Two-speed propel with planetary gear reduction and automatically engaged multiple-wet-disk brakes

Large cab for improved operator comfort and visibility

Vandal protection—lockable cab and service doors

690C EXCAVATOR SPECIFICATIONS

Specifications and design subject to change without notice. Wherever applicable, specifications are in accordance with PCSA and SAE Standards. Except where otherwise noted, these specifications are based on a unit with 36-in. (900 mm) bucket, 24-in. (600 mm) track shoes, full fuel tank, 175 lb. (80 kg) operator and standard equipment.

Rated Power @ 1900 rpm:	SAE	DIN 6270
Net	125 hp (93 kW)	93 kW
Gross	134 hp (100 kW)	

Net engine power is with standard equipment including air cleaner, exhaust system, alternator, and cooling fan, at standard conditions per SAE J1349 and DIN 6270 using No. 2-D fuel @ 35 API gravity. No derating is required up to 10,000 ft. (3050 m) altitude. Gross power is without cooling fan.

Engine: John Deere 6-466T

Type	4-stroke cycle, turbocharged diesel
Bore and stroke	4.56 x 4.75 in. (116 x 121 mm)
No. of cylinders	6
Displacement	466 cu. in. (7,638 L)
Compression ratio	14.9 to 1
Maximum net torque @ 1300 rpm	450 lb-ft (610 Nm) (62.2 kg-m)
Lubrication	Pressure system with full-flow filter
Cooling fan	Suction type
Air cleaner w/restriction indicator and safety element	Dry
Electrical system	24-volt with 42-amp alternator
Batteries (two 12-volt)	Reserve capacity: 160 minutes

Hydraulic System: Open center

Two open-center pumps mounted in tandem are coupled directly to the flywheel, through an isolator.	
Total rated pump flow	84 gpm (5.30 L/s)
System operating pressure	2500 psi (17 238 kPa) (175.7 kg/cm ²)

Relief valves:

Boom (2)	Rod, 3000 psi (20 685 kPa) (210.9 kg/cm ²)	Head, 3750 psi (25 856 kPa) (263.6 kg/cm ²)
Arm (2)	3000 psi (20 685 kPa) (210.9 kg/cm ²)	
Bucket (2)	3000 psi (20 685 kPa) (210.9 kg/cm ²)	

Oil filtration:

One 4-micron full-flow return filter with bypass	
One 40-micron pilot oil filter	
Oil cooler	All brazed aluminum hydraulic oil cooler, mounted side by side with engine coolant radiator.
Hydraulic connections	Flat-face O-ring type

Cylinders:	Bore	Rod Diameter	Stroke
Boom (2)	5.0 in. (127 mm)	2.75 in. (70 mm)	43.75 in. (1111 mm)
Arm	5.5 in. (140 mm)	3.25 in. (83 mm)	63.19 in. (1605 mm)
Bucket	5.5 in. (140 mm)	3.25 in. (83 mm)	40.51 in. (1029 mm)

All cylinders have phenolic wear rings. Boom and arm cylinders have a built-in hydraulic cushion at each end of stroke. Bucket cylinder has hydraulic cushion at rod end. All cylinder rods are ground, heat treated, chrome plated and polished.

Swing Mechanism:

Swing	360 degrees; hydraulic motor with integral crossover reliefs and multiple reduction spur and planetary gearing.
Swing brake	Hydraulically released, spring applied, multiple wet-disk.
Swing bearing	Single row ball with internal drive, induction hardened ring and pinion gears and 500-hour lubrication interval. In-cab fitting for swing bearing lubrication.

Undercarriage:

Propel system (one for each track)	High-torque, 2-speed hydraulic motors with planetary and spur gear reduction drives. Wet multiple-disk brakes automatically release while propelling, and apply when stationary. Independent drive to each track permits counterrotation.
Undercarriage and track frame	Each track frame is a formed, reinforced U-channel. A reinforced undercarriage frame joins the track frame to the swing bearing mount. Narrow or wide undercarriage frames available.
Track rollers and idlers	Nine rollers and one idler per track. All rollers and idlers have metal-faced seals. Idlers have heavy-duty spring recoil mechanisms. Through-hardened steel slides support and guide upper track.
Track adjustment	Hydraulic

Track Shoes:	Shoes	Ground Contact	Average Ground Pressure
24 in. (600 mm) (standard)	Triple semigrouser	6136 sq. in. (39 587 cm ²)	6.5 psi (44.8 kPa) (0.46 kg/cm ²)
30 in. (750 mm) (optional)	Triple semigrouser	7670 sq. in. (49 484 cm ²)	5.3 psi (36.5 kPa) (0.37 kg/cm ²)

Cab:

Large, isolation-mounted, with sound-absorbing materials on ceiling and sidewalls. Safety glass windows. Front window can be stored overhead. Rear window, door, and roof hatch open for ventilation.

Seat:

Deluxe, fully cushioned, vinyl covered, with adjustable backrest, headrest and padded fold-up armrests. Independent horizontal and vertical adjustments.

Controls:

All hydraulic functions are pilot controlled for precise metering and low operator effort. Two levers control swing, boom, arm, and bucket functions. Right and left pedals control forward, reverse and counterrotation movements. All controls are deactivated by a lever on the left console.

Boom and Arm:

Internally reinforced tapered-box construction with heat-treated steel bushings. Machined and line-bored after welding for accurate alignment. Centralized lubrication system.

Servicing and Vandal Protection:

Swingaway service doors expose built-in service platforms and handrails. Hinged hood provides easy access to engine and hydraulic systems. Built-in key locks secure cab and service access areas.

Additional Standard Equipment:

- Cab:**
 - Heater, 13,500 Btu/hr (4 kW)
 - Horn
 - Interior light
 - Positive position hand throttle
 - Windshield wiper
 - Monitor system with alarm features:
 - Engine air cleaner restriction indicator light
 - Engine alternator charge indicator light
 - Engine coolant temperature warning light w/audible alarm
 - Engine oil pressure warning light w/audible alarm
 - Flow divider indicator light
 - Hydraulic oil filter restriction indicator light
 - Gauges:
 - Engine coolant temperature gauge
 - Fuel gauge
 - Hydraulic oil temperature gauge
 - Quartz hourmeter
- Engine:**
 - Full-flow oil filter
 - Dual dry-type air filter
 - Dual heavy-duty fuel filters
 - Low maintenance batteries
 - Underhood muffler
- Frame:**
 - Hinged engine cover
 - Built-in service platforms
 - 4280-lb. (1940 kg) counterweight
- Undercarriage:**
 - Propel motor shields
 - Pull loops
 - Single flange track rollers
 - Upper track slides

Optional or Special Equipment:

- Cab:**
 - Air conditioner with integral heater
 - Air conditioner, 20,000 Btu/h (5.8 kW/h)
 - Heater, 40,000 Btu/h (11.7 kW/h)
 - Alternate pilot control pattern
 - Window protection covers
- Engine:**
 - Ether starting aid
 - Four-battery system with 320 minutes reserve capacity
 - Coolant heater
- Frame:**
 - Auxiliary counterweight system, 1100-lb. (500 kg) or 2200-lb. (1000 kg)
- Front attachments:**
 - Bucket linkage load lifting loop
 - Buckets and attachments
 - Bucket side cutters and teeth
 - Worklights—two boom-mounted
- Undercarriage:**
 - 30-in. (750 mm) triple semigrouser shoes

690C EXCAVATOR SPECIFICATIONS

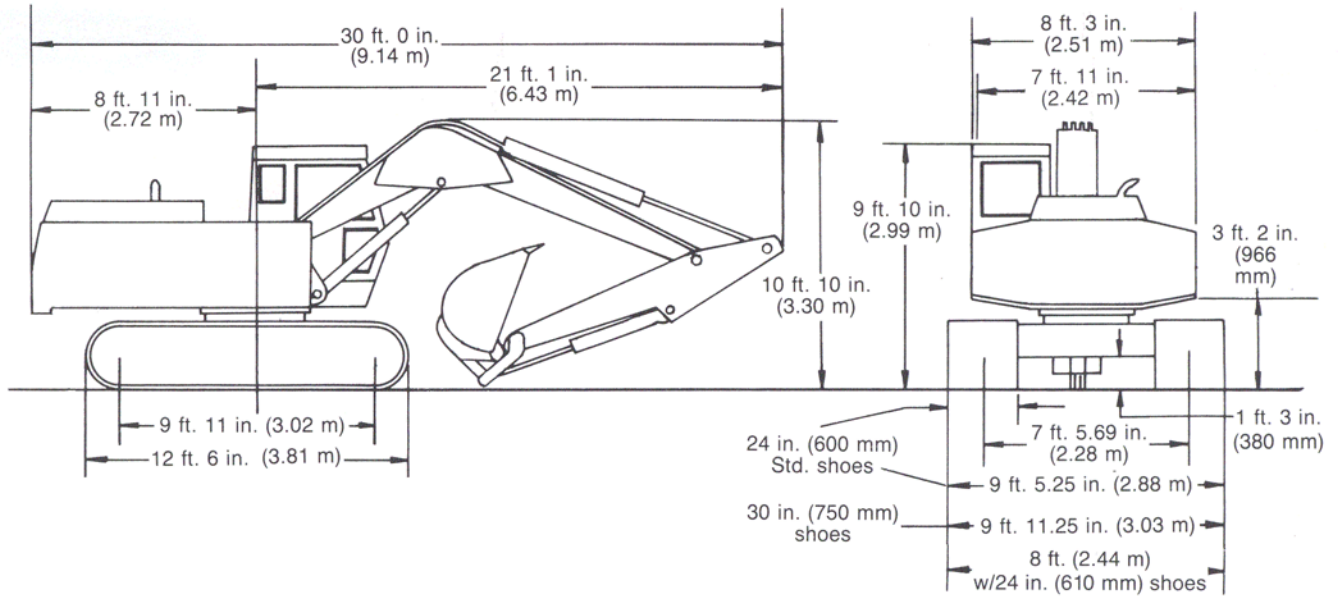

Operating Information:

Max. digging depth	21 ft. (6.40 m)
Max. reach at ground level	30 ft. (9.14 m)
Max. dumping height	15 ft. (4.57 m)
Gradability	70% (35°)
Swing speed	0-7.8 rpm
Travel speeds: Low range	0 to 0.9 mph (1.5 km/h)
High range	0 to 1.8 mph (2.8 km/h)

Weights:

	lb.	kg
Operating weight (w/full fuel tank, operator, and bucket) with:		
24-in. (600 mm) triple grouser shoes	39,935	18 115
30-in. (750 mm) triple grouser shoes	40,895	18 550
Upperstructure (less front attachment and undercarriage)	15,530	7045
Undercarriage:		
24-in. (600 mm) triple-grouser shoes	17,020	7720
30-in. (750 mm) triple-grouser shoes	17,980	8155
One-piece boom (with arm cylinder)	3,350	1520
Arm, 108.14 in. (2.75 m) w/bucket cylinder and linkage	2,165	980
Boom lift cylinders, total weight (2)	515	234
Main counterweight	4,280	1940
Optional auxiliary counterweights (per set)	1,100	500
(Two sets available)		

Capacities:

	U.S.	Liters
Fuel tank	70 gal.	265
Cooling system	42 qt.	40
Engine lubrication, including filter	25 qt.	24
Hydraulic system	80 gal.	303
Planetary propel drive (each)	10 qt.	9.5
Swing drive	8 qt.	7.6
Swing planetary drive	0.4 qt.	0.4

Digging Depth and Reach:

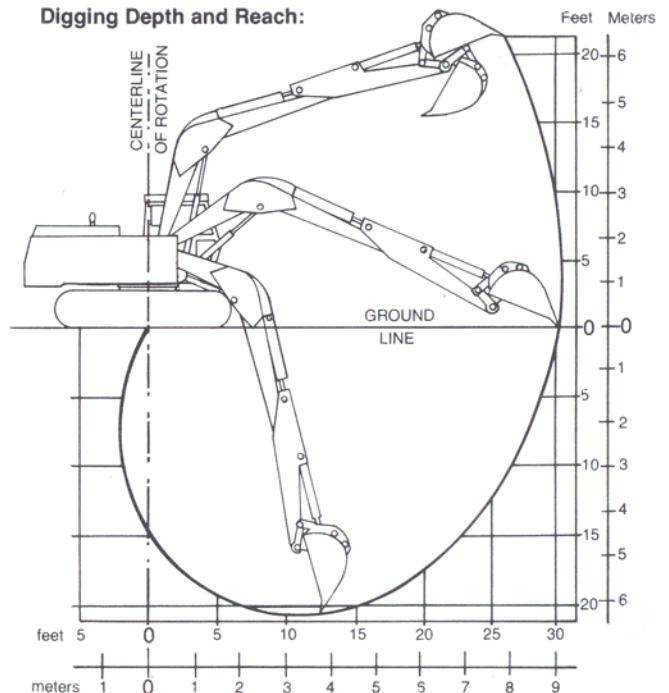

690C EXCAVATOR LIFTING CAPACITIES

Ratings at bucket lift hook, machine situated on firm, uniform supporting surface. Total load includes weight of cables, hook, etc. Boldface type indicates hydraulic-limited capacities, lightface type indicates stability-limited capacities, in lb. (kg). Figures do not exceed 87 percent of hydraulic capacities or 75 percent of weight needed to tip machine. Add 8 percent to stability-limited capacities when optional 1100-lb. (500 kg) counterweight is used. Add 16 percent to stability-limited capacities when optional 2200-lb. (1000 kg) counterweight is used.

BOOM lifting, over front or rear, arm holding

Horizontal distance from centerline of rotation:	10 ft. (3.05 m)	15 ft. (4.57 m)	20 ft. (6.10 m)	25 ft. (7.62 m)	30 ft. (9.14 m)	
15 ft. (4.57 m)				4,260 (1930)		
10 ft. (3.05 m)			5,360 (2430)	4,710 (2140)		
5 ft. (1.52 m)		9,230 (4190)	6,390 (2900)	5,250 (2380)	4,210 (1910)	
Ground level		13,910 (6310)	10,630 (4820)	7,260 (3290)	5,680 (2580)	
- 5 ft. (- 1.52 m)		17,560 (7970)	10,970 (4980)	7,700 (3490)	5,810 (2640)	
- 10 ft. (- 3.05 m)	16,140 (7320)	10,380 (4710)	7,360 (3340)			
- 15 ft. (- 4.57 m)	12,340 (5600)	7,820 (3550)				

ARM lifting, over front or rear, boom holding

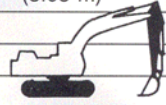
Horizontal distance from centerline of rotation:	10 ft. (3.05 m)	15 ft. (4.57 m)	20 ft. (6.10 m)	25 ft. (7.62 m)	30 ft. (9.14 m)	
15 ft. (4.57 m)				6,460 (2930)		
10 ft. (3.05 m)			9,440 (4280)	7,070 (3210)		
5 ft. (1.52 m)		14,830 (6730)	9,550 (4330)	6,770 (3070)	3,320 (1510)	
Ground level		11,320 (5130)	14,350 (6510)	9,230 (4190)	6,590 (2990)	
- 5 ft. (- 1.52 m)		17,160 (7780)	14,270 (6470)	9,110 (4130)	6,530 (2960)	
- 10 ft. (- 3.05 m)	26,300 (11 930)	14,460 (6560)	9,210 (4180)			
- 15 ft. (- 4.57 m)	20,900 (9480)	13,520 (6130)				

BOOM lifting, over the side, arm holding, upperstructure 90 degrees to tracks

Horizontal distance from centerline of rotation:	10 ft. (3.05 m)	15 ft. (4.57 m)	20 ft. (6.10 m)	25 ft. (7.62 m)	30 ft. (9.14 m)	
15 ft. (4.57 m)				4,260 (1930)		
10 ft. (3.05 m)			5,360 (2430)	4,710 (2140)		
5 ft. (1.52 m)		9,230 (4190)	6,390 (2900)	5,060 (2300)	3,780 (1710)	
Ground level		13,910 (6310)	10,400 (4720)	6,820 (3090)	4,890 (2220)	
- 5 ft. (- 1.52 m)		17,560 (7970)	10,330 (4690)	6,720 (3050)	4,830 (2190)	
- 10 ft. (- 3.05 m)	16,140 (7320)	10,380 (4710)	6,810 (3090)			
- 15 ft. (- 4.57 m)	12,340 (5600)	7,820 (3550)				

ARM lifting, over the side, boom holding, upperstructure 90 degrees to tracks

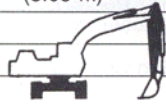
Horizontal distance from centerline of rotation:	10 ft. (3.05 m)	15 ft. (4.57 m)	20 ft. (6.10 m)	25 ft. (7.62 m)	30 ft. (9.14 m)	
15 ft. (4.57 m)				5,470 (2480)		
10 ft. (3.05 m)			7,340 (3330)	5,340 (2420)		
5 ft. (1.52 m)		10,830 (4910)	7,130 (3230)	5,060 (2300)	3,320 (1510)	
Ground level		11,320 (5130)	10,400 (4720)	6,820 (3090)	4,890 (2220)	
- 5 ft. (- 1.52 m)		17,160 (7780)	10,330 (4690)	6,720 (3050)	4,830 (2190)	
- 10 ft. (- 3.05 m)	20,570 (9330)	10,500 (4760)	6,810 (3090)			
- 15 ft. (- 4.57 m)	20,900 (9480)	10,960 (4970)				

690C EXCAVATOR BUCKETS

Buckets: High-strength steel, ribbed and double plated bottom section, loading and power digging positions.

Nominal Width	Bite Width	Capacity SAE (Heaped)	Weight
Regular duty			
24 in. (600 mm)	25.4 in. (645 mm)	0.56 cu. yd. (0.43 m ³)	1000 lb. (455 kg)
30 in. (750 mm)	31.4 in. (798 mm)	0.75 cu. yd. (0.57 m ³)	1100 lb. (500 kg)
36 in. (900 mm)	37.4 in. (950 mm)	0.88 cu. yd. (0.67 m ³)	1200 lb. (545 kg)
48 in. (1220 mm)	49.4 in. (1250 mm)	1 cu. yd. (0.76 m ³)	1200 lb. (545 kg)
60 in. (1520 mm)	60.0 in. (1520 mm)	1.38 cu. yd. (1.05 m ³)	1200 lb. (545 kg)
Heavy duty			
24 in. (600 mm)	26.0 in. (660 mm)	0.625 cu. yd. (0.48 m ³)	1380 lb. (625 kg)
29 in. (740 mm)	31.0 in. (787 mm)	0.75 cu. yd. (0.57 m ³)	1500 lb. (680 kg)
35 in. (890 mm)	37.0 in. (940 mm)	0.75 cu. yd. (0.57 m ³)	1525 lb. (690 kg)

ARM AND BUCKET DIGGING FORCES

Buckets Bucket Width	Arm Digging Forces	Bucket Tangential Digging Forces
Regular duty		
24-, 30-, or 36-in. (600, 750, or 900 mm)	13,290 lb. (59 kN) (6028 kg)	25,780 lb. (115 kN) (11 694 kg)
48-in. (1220 mm)	14,065 lb. (63 kN) (6380 kg)	30,945 lb. (138 kN) (14 037 kg)
60-in. (1520 mm)	14,465 lb. (64 kN) (6561 kg)	33,981 lb. (151 kN) (15 414 kg)
Heavy duty		
24- or 29-in. (600 or 740 mm)	13,475 lb. (60 kN) (6112 kg)	26,695 lb. (119 kN) (12 109 kg)
35-in. (890 mm)	13,880 lb. (62 kN) (6296 kg)	29,210 lb. (130 kN) (13 250 kg)

BUCKET SELECTION CHART				
Recommended Bucket Size*				
lb/yd ³	kg/m ³	MATERIAL	Regular Duty	Heavy Duty
700	420	Wood chips	5 cu. yd. (3.8 m ³)	—
810	480	Peat, dry	4.5 cu. yd. (3.4 m ³)	—
1242	740	Peat, wet	3 cu. yd. (2.3 m ³)	—
1450	860	Cinders	2.5 cu. yd. (1.9 m ³)	—
2000	1186	Topsoil	1.8 cu. yd. (1.4 m ³)	—
2600	1540	Earth, dry loam	1.38 cu. yd. (1.05 m ³)	—
2700	1600	Sand, dry	1.38 cu. yd. (1.05 m ³)	1 cu. yd. (.8 m ³)
3000	1780	Coal, natural bed	1.12 cu. yd. (.9 m ³)	1 cu. yd. (.8 m ³)
3200	1900	Earth, moist loam	1.12 cu. yd. (.9 m ³)	0.88 cu. yd. (.7 m ³)
3250	1930	Sand, gravel, dry	1.12 cu. yd. (.9 m ³)	0.88 cu. yd. (.7 m ³)
3300	1960	Sand, moist	1.12 cu. yd. (.9 m ³)	0.88 cu. yd. (.7 m ³)
3500	2080	Sand, wet	1 cu. yd. (.8 m ³)	0.75 cu. yd. (.6 m ³)
3500	2080	Shale	1 cu. yd. (.8 m ³)	0.75 cu. yd. (.6 m ³)
4200	2490	Limestone, broken	—	0.62 cu. yd. (.5 m ³)
4300	2550	Clay, wet	0.88 cu. yd. (.7 m ³)	0.62 cu. yd. (.5 m ³)
4600	2730	Rock, granite, blasted	—	0.62 cu. yd. (.5 m ³)

*Contact your John Deere dealer for optimum bucket and attachment selection. The use of larger than recommended buckets in heavy materials and tough conditions should be carefully analyzed for digging force and load capacity. Bucket capacity indicated is SAE heaped.