

FELLER BUNCHERS

753J/759J/903K/909K/953K/959K TRACKED



JOHN DEERE



Tough bunch of fellers.

Loggers demand maximum productivity and uptime out of their equipment, shift after shift. And John Deere 700J-Series and 900K-Series Tracked Feller Bunchers deliver, big time. Each features a powerful fuel-efficient engine, fast hydraulics for superb multifunction operation, deep cutting swath, and best-in-class head accumulation for maximum productivity. Quick, wide-open access to service items and major components along with simplified maintenance help maximize uptime. Plus, the spacious, well-appointed cab provides everything operators need to bring out their very best. With one of these tough feller bunchers on your jobsite, working hard has never been so easy.





KEEP BACK
300 FT / 90 M

753J

JOHN DEERE



Ready, willing, and stable.

When you are ready to increase productivity, choose a 700J-Series Feller Buncher. Combining faster hydraulics, 50-percent-more cutting swath, and a best-in-class boom, these powerful, agile machines give you more muscle to handle more trees, with a faster saw-recovery time. 700J-Series Feller Bunchers are not only plenty able, but very stable. Choose the larger U7 undercarriage option on the 753J for even more stability in rugged terrain. The 759J's industry-exclusive Shift-Tilt™ leveling system provides the leverage needed for cutting on steep slopes.



Best-in-class boom increases cutting efficiency and optimizes cutting time, maximizing productivity.

Fast, cool hydraulics ensure smooth multifunction operation, no waiting for power — or oil. Get more done, faster, with more precision.

Cutting swath increased 50 percent, so operators can make more strategic and productive cuts with less tracking and traveling.

Attachment valve location improves overall felling-head efficiency and cycle times. The simplified design eliminates 20 connections and over 100 feet of hoses and tubes.

Shift-Tilt auto-leveling system provides superb stability for cutting on difficult slopes. Four-way leveling shifts the upper structure a full three feet forward, optimizing the machine's center of gravity on steep inclines.

Larger U7 undercarriage option provides additional stability for handling hilly or rocky terrain on the 753J, adding over 5,000 pounds and 11 inches of length. With increased ability to gather full loads, operators will be more productive.

State-of-the-art diagnostics on the 700J-Series Powerview™ monitor help speed troubleshooting and decrease downtime.

Tame the toughest woods.

The worst of the woods brings out the best in a 900K-Series Feller Buncher. Large-displacement 9.0L engine delivers the power you need to get the job done quickly and efficiently, while conserving fuel. The best-in-class leveling system keeps you steady and centered on rocky or steep terrain. Plus, the enhanced multifunction LCD color monitor provides quick push-button access to a wealth of machine info and superior onboard diagnostics to keep you up and running. And ready to take on whatever the woods throw your way.



Engine delivers from 300 to 330 horsepower, ensuring superior swing torque, boom performance, and tracking on K-Series models — without compromising best-in-class fuel efficiency. And the 295-gallon fuel tank lets you get more done between fill-ups.

CommandCenter™ advanced display unit shows operating, diagnostic, and maintenance info on a color LCD screen with **easy-on-the-eyes clarity**. Best-in-class onboard diagnostics simplify preventative maintenance work and troubleshooting for increased uptime.

Sealed-switch module keeps out dust, moisture, and debris, so it **virtually never wears out**. Proven marine-grade touchpad eliminates rocker switches, numerous wires, and unsealed connections, and lasts 10 times longer than standard dash switches.

Hydraulically actuated door to the engine and pump enclosure ensures fast service access, for **easy and efficient maintenance**.

Standard reversing cooling fan automatically clears leaves, pine straw, and other debris from the grill, for **better airflow to the engine**.

Robust hydraulics system ensures long-lasting reliability. The power-management system ensures no horsepower is wasted, for smooth multifunction operation.

Best-in-class leveling system keeps the upper frame parallel to the ground, even when the tracks are climbing or tilting. The system tilts 26 degrees forward, seven degrees rearward, and 14 degrees to either side, keeping the operator in a comfortable, level position.





Brings a whole new meaning to the term “mobile office.”

Who wouldn't be more productive working from the fully adjustable suspension seat of a John Deere feller buncher? The comfortable, well-appointed cab offers plenty of space to get things done. Quiet and smooth running, too, with isolation mountings to reduce noise and vibration. A wide expanse of glass provides excellent all-around visibility. And a high-power HVAC system ensures year-round comfort. Other fatigue-beating amenities include an AM/FM/CD/AUX radio, two 12-volt power ports, generous storage space for cell phones and other carryons, and bright cab lighting. Everything your operator needs to conduct business “on the go” — and be more productive longer.



1

2

3

1. Visibility is virtually unobstructed, due to the wide expanse of front and side glass, a skylight, and a bottom window (900K Series). An optional sunshade for the rear window on 900K-Series machines keeps the cab cooler, while reducing glare.
2. Joysticks and low-effort controls with backlit indicators are conveniently located within the adjustable armrests.
3. Tree counter (900K Series) operates in either automatic or manual mode. Automatic mode counts stems based on follow-arm sequencing and saw rpm pull-down. Manual mode tracks each tree cut with a push of the button on the joystick.

Fatigue-beating joysticks with smooth, responsive hydraulics put intuitive control at your fingertips.

JDLink on 900K-Series machines gives you 24/7 online access to machine location. Track machine health, utilization, and fuel consumption — valuable information that helps you better understand costs and jobsite performance. Plus, you can help protect your machine from theft by setting up geofence and curfew alerts in your JDLink account.

Rapid Cycle System (RCS) boom option

This option for 900K-Series machines allows faster, low-effort boom control using only a single joystick — for more productivity with less fatigue. RCS includes the following features:

- **Straight-Line Rapid Cycle Boom** — single forward motion of the boom/stick/head engaged using joystick.
- **Auto Head Level** — automatically maintains the head's cutting position throughout the boom-reach cycle.
- **Auto Arm Sequencing** — grab-arms and accumulator-arms automatically sequence to gather cut trees with the press of a single joystick button.
- **Quick Release** — all four arms open simultaneously for a quick bunch release with the press of a single joystick button.



Our felling heads are at the head of their class.

Delivering superior accumulation capacity, our high-rotation heads allow you to cut more wood from one position and load each skidder to capacity from a single bunch. Our patented offset disc saw blade keeps you moving at high rpm without slowing or stopping. These rugged felling heads won't let you down either. The wrist delivers triple the life expectancy, and the saw housing prevents vines, chips, and sap from binding.



FS20 felling head for 700J-Series machines delivers top-ranked mixed-stand accumulation capacity. Ideal for small-diameter thinning or handling large single stems up to 20 inches.

High-rotation FR26 and FR24B felling heads for 900K-Series machines cut more wood from one position to give the skidder a full load from a single bunch.

Versatile 30-degree wrist on the FS20 provides ± 15 -degree rotation and strong clamping force. Wider arm spacing and horn design deliver a high-accumulation capacity for increased productivity.

Patented offset disc saw blade and one-piece rotatable teeth on the K-Series keep the saw moving — and you from waiting.

Three-piece saw housing is bolted, not welded, for easier service. And it's protected by a wear plate for longer life.

Offset horn design and superior gathering arm keep stems aligned to hold larger bunches with better control and less stem breakage.



1. Deere-designed high-rotation wrist delivers best-in-class accumulation capacity. Its more compact design improves visibility to the felling head for increased productivity.

2. New high-rotation FR21B felling head for 700J-Series Feller Bunchers enables loggers to cut more trees, track less, and be more productive. Superior pickup force allows effortless placement of fallen trees.

3. A gate blocks chips from entering the saw housing, preventing clogging. Wide-open exit area further prevents buildup.

3



Cuts costs while cutting timber.

Cutting wood isn't the only area where your John Deere tracked feller buncher excels. Lowering daily operating costs and simplifying maintenance are among the many other things it does well. Deere diesels deliver best-in-class fuel efficiency. Easy, wide-open access to checkpoints makes quick work of daily checks, while a clean hydraulics layout, common hydraulic components, and spin-on filters ease periodic maintenance. Plus, industry-leading parts and service are always within easy reach.

1. Quick, wide-open access to service items and major components speeds daily checks and periodic maintenance. Maintenance work that used to cost you a day now takes just an hour.
2. Streamlined, easily accessible hydraulic systems make maintenance a breeze, increasing uptime and lowering daily operating costs. Common hydraulic reservoir internal components such as independent suction lines, case-drain filtration, and common return filters simplify changes and keep costs down.
3. Optional platform counterweight on 700J-Series machines features slip-resistant surfaces and a convenient ladder to help ensure safer and easier service.
4. New boom debris guard on the 700J Series prevents nearly all debris from entering the engine compartment.





753J



KEEP BACK
10011506

FR 218

1

3

753J / 759J



Engine	753J		759J
Manufacturer and Model	John Deere PowerTech™ 6081H		John Deere PowerTech 6081H
Non-Road Emission Standards	EPA Tier 2/EU Stage II		EPA Tier 2/EU Stage II
Displacement	8.1 L (494 cu. in.)		8.1 L (494 cu. in.)
Peak Power at 2,000 rpm	180 kW (241 hp)		180 kW (241 hp)
Net Power (ISO 9249) at 2,000 rpm	164 kW (220 hp)		164 kW (220 hp)
Net Peak Torque at 1,400 rpm	1230 Nm (907 lb.-ft.)		1230 Nm (907 lb.-ft.)
Fuel Tank	584 L (154 gal.)		584 L (154 gal.)
Cooling	753J / 759J		
Fan Type	Suction type, belt driven		
Powertrain	753J		759J
Undercarriage	U6 (standard)	U7 (optional)	U6 (standard)
Travel Speed, Forward and Reverse:			
High	3.8 km/h (2.4 mph)	3.5 km/h (2.2 mph)	3.8 km/h (2.4 mph)
Low	1.8 km/h (1.1 mph)	1.6 km/h (1.0 mph)	1.8 km/h (1.1 mph)
Tractive Effort	256 kN (57,600 lbf)	292 kN (65,500 lbf)	256 kN (57,600 lbf)
Travel Brakes	Sealed, wet, multi-disc, automatic application, integral with track-drive gearboxes		
Hydraulics	753J / 759J		
Main Pump:	Variable-displacement, axial-piston		
Maximum Rated Flow	360 L/min. (95 gpm)		
Continuous Saw Pump:	Dedicated variable-displacement, axial-piston		
Maximum Rated Flow	114 L/min. (30 gpm)		
Attachment Pump:	Dedicated axial-piston		
Maximum Rated Flow	135 L/min. (35 gpm)		
Oil Filtration	2 main return filters, 10-micron return with bypass		
Electrical			
Voltage	24 volt		24 volt
Batteries	2 x 12 volt		2 x 12 volt
Alternator Rating	80 amp		80 amp
Work Lights	Halogen, 8 twin power (7 flood and 1 spot)		Halogen, 8 twin power (7 flood and 1 spot)
Undercarriage	753J		759J
Undercarriage	U6 (standard)	U7 (optional)	U6 (standard)
Track Gauge	2560 mm (101 in.) standard / 2285 mm (90 in.) optional narrow	2560 mm (101 in.)	2438 mm (96 in.)
Track Shoes, Single-Bar Grouser, Clipped Corner, Heavy Duty, Open Center	610 mm (24.0 in.)	610 mm (24.0 in.)	610 mm (24.0 in.)
Track Chain, Heavy Duty	203.2 mm (8.0 in.)	215.9 mm (8.5 in.)	203.2 mm (8.0 in.)
Carrier Slides (per side)	2 bolt-on	2 bolt-on	2 bolt-on
Shoes (per side)	45	45	45
Track Rollers (per side)	8 (tractor type)	9 (tractor type)	8 (tractor type)
Track Guides, Integral, Thick High-Abrasion-Resistant Material	25 mm (1.0 in.)	25 mm (1.0 in.)	25 mm (1.0 in.)
Ground Contact Area (with standard shoe)	4.6 m ² (7,053 sq. in.)	4.9 m ² (7,541 sq. in.)	4.6 m ² (7,053 sq. in.)
Track Adjustment	Hydraulic	Hydraulic	Hydraulic
Swing Mechanism			
Swing Speed (maximum)	7.0 rpm		7.0 rpm
Swing Torque	54 233 Nm (40,000 lb.-ft.)		54 233 Nm (40,000 lb.-ft.)
Swing Brake	Sealed, wet, multi-disc		Sealed, wet, multi-disc
Ground Pressure Data			
SAE J1309 (less attachment) / Undercarriage	U6 (standard)	U7 (optional)	U6 (standard)
Double Grouser, Heavy Duty:			
610 mm (24 in.)	51.5 kPa (7.5 psi)	52.4 kPa (7.6 psi)	59.0 kPa (8.6 psi)
760 mm (30 in.)	42.0 kPa (6.1 psi)	46.0 kPa (6.7 psi)	N/A
Single Grouser, Clipped Corner, Heavy Duty:			
610 mm (24 in.)	51.0 kPa (7.4 psi)	56.1 kPa (8.1 psi)	58.6 kPa (8.5 psi)
711 mm (28 in.)	44.3 kPa (6.4 psi)	48.9 kPa (7.1 psi)	50.8 kPa (7.4 psi)
Triple Grouser, Heavy Duty (for soft terrain only):			
914 mm (36 in.)	36.2 kPa (5.3 psi)	39.6 kPa (5.7 psi)	N/A



Operating Weight		753J		759J	
Includes standard equipment, half-full fuel tank, all fluids, 80-kg (175 lb.) operator (less attachment)					
Undercarriage	U6 (standard)	U7 (optional)	U6 (standard)	U6 (standard)	U6 (standard)
Approximate Weight	23 680 kg (52,220 lb.)	26 036 kg (57,410 lb.)	27 180 kg (59,940 lb.)	27 180 kg (59,940 lb.)	27 180 kg (59,940 lb.)
Attachment Information		753J		759J	
Attachment	FS20 (standard)	FR21B (optional)	FS20 (standard)	FR21B (optional)	FR21B (optional)
Maximum Cutting Capacity	559 mm (22.0 in.)	545 mm (21.5 in.)	559 mm (22.0 in.)	545 mm (21.5 in.)	545 mm (21.5 in.)
Maximum Accumulation Capacity	0.43 m ² (4.6 sq. ft.)	0.46 m ² (5.0 sq. ft.)	0.43 m ² (4.6 sq. ft.)	0.46 m ² (5.0 sq. ft.)	0.46 m ² (5.0 sq. ft.)
Opening at Front of Housing	983 mm (38.7 in.)	1180 mm (46.5 in.)	983 mm (38.7 in.)	1180 mm (46.5 in.)	1180 mm (46.5 in.)
Blade Diameter	1422 mm (56 in.)	1372 mm (54 in.)	1422 mm (56 in.)	1372 mm (54 in.)	1372 mm (54 in.)
Number of Teeth	18	18	18	18	18
Wrist	30 deg.	302 deg.	30 deg.	302 deg.	302 deg.
Width at Saw Housing	1600 mm (63 in.)	1550 mm (61 in.)	1600 mm (63 in.)	1550 mm (61 in.)	1550 mm (61 in.)
Height	2794 mm (110 in.)	2820 mm (111 in.)	2794 mm (110 in.)	2820 mm (111 in.)	2820 mm (111 in.)
Weight (including adapter and wrist)	2630 kg (5,800 lb.)	3039 kg (6,700 lb.)	2630 kg (5,800 lb.)	3039 kg (6,700 lb.)	3039 kg (6,700 lb.)

See individual felling head brochure for further details.

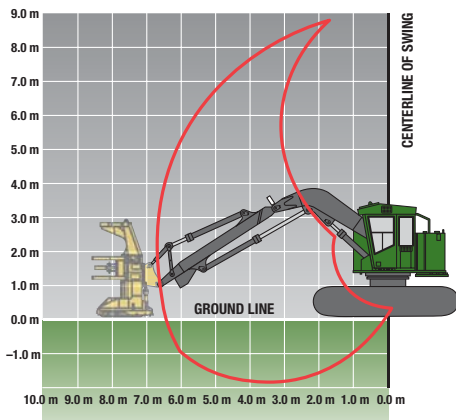

753J Track Feller Buncher

Standard Boom Performance		753J	
Attachment	FS20	FR21B	
Lift Capacity (bare pin):			
At Full Reach	4720 kg (10,400 lb.)	4720 kg (10,400 lb.)	
At 6.1 m (20 ft. 0 in.)	5220 kg (11,500 lb.)	5220 kg (11,500 lb.)	
Reach (to tip of saw blade):			
Maximum	8.40 m (27 ft. 6 in.)	8.41 m (27 ft. 7 in.)	
Minimum	3.22 m (10 ft. 6 in.)	3.23 m (10 ft. 7 in.)	
Cutting Swath (all heads)	5.18 m (17 ft. 0 in.)	5.18 m (17 ft. 0 in.)	

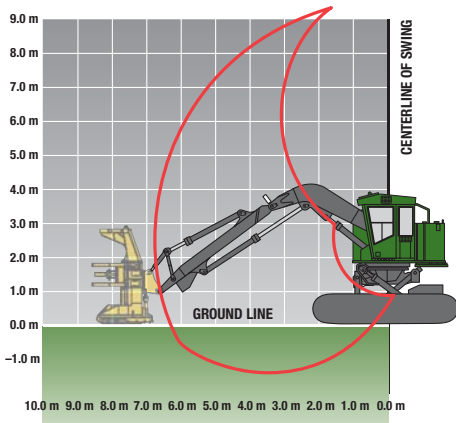

759J Track Feller Buncher

Standard Boom Performance		759J	
Attachment	FS20	FR21B	
Lift Capacity (bare pin):			
At Full Reach	4720 kg (10,400 lb.)	4720 kg (10,400 lb.)	
At 6.1 m (20 ft.)	5220 kg (11,500 lb.)	5220 kg (11,500 lb.)	
Reach (to tip of saw blade):			
Maximum	8.40 m (27 ft. 6 in.)	8.41 m (27 ft. 7 in.)	
Minimum	3.22 m (10 ft. 6 in.)	3.23 m (10 ft. 7 in.)	
Cutting Swath (all heads)	5.18 m (17 ft. 0 in.)	5.18 m (17 ft. 0 in.)	

Machine Dimensions	753J	759J
Undercarriage	U6 (standard)	U7 (optional) / U6 (standard)
A Overall Height:		
(1) Top of Cab	3.45 m (11 ft. 4 in.)	3.51 m (11 ft. 6 in.)
(2) Top of Boom	3.96 m (13 ft. 0 in.)	3.96 m (13 ft. 0 in.)
B Overall Track Length	4.41 m (14 ft. 6 in.)	4.69 m (15 ft. 5 in.)
C Track Length (idler to sprocket center)	3.37 m (11 ft. 1 in.)	3.62 m (11 ft. 10 in.)
D Tail Swing (from swing centerline):		
Short Counterweight	1.93 m (6 ft. 4 in.)	1.93 m (6 ft. 4 in.)
Long Counterweight	2.18 m (7 ft. 2 in.)	2.18 m (7 ft. 2 in.)
E Boom Reach (to attachment pin):		
Maximum	6.71 m (22 ft. 0 in.)	6.71 m (22 ft. 0 in.)
Minimum	1.52 m (5 ft. 0 in.)	1.52 m (5 ft. 0 in.)
Cutting Swath	5.18 m (17 ft. 0 in.)	5.18 m (17 ft. 0 in.)
F Ground Clearance:		
Single Grouser	730 mm (29 in.)	730 mm (29 in.)
Double Grouser	711 mm (28 in.)	711 mm (28 in.)
Triple Grouser	685 mm (27 in.)	685 mm (27 in.)
G Upperstructure Width	2.94 m (9 ft. 8 in.)	2.94 m (9 ft. 8 in.)
H Track Gauge	2.57 m (8 ft. 5 in.) standard / 2.29 m (7 ft. 6 in.) optional narrow	2.57 m (8 ft. 5 in.)
I Width Over Tracks:		
610-mm (24 in.) Track Shoes	3.18 m (10 ft. 5 in.) standard / 2.90 m (9 ft. 6 in.) narrow	3.18 m (10 ft. 5 in.)
711-mm (28 in.) Track Shoes	3.28 m (10 ft. 9 in.) standard / 3.00 m (9 ft. 10 in.) narrow	3.28 m (10 ft. 9 in.)
760-mm (30 in.) Track Shoes	3.33 m (10 ft. 11 in.) standard / 3.05 m (10 ft. 0 in.) narrow	3.33 m (10 ft. 11 in.)
914-mm (36 in.) Track Shoes	3.48 m (11 ft. 5 in.) standard / 3.20 m (10 ft. 6 in.) narrow	3.48 m (11 ft. 5 in.)

753J / 759J Track Feller Buncher

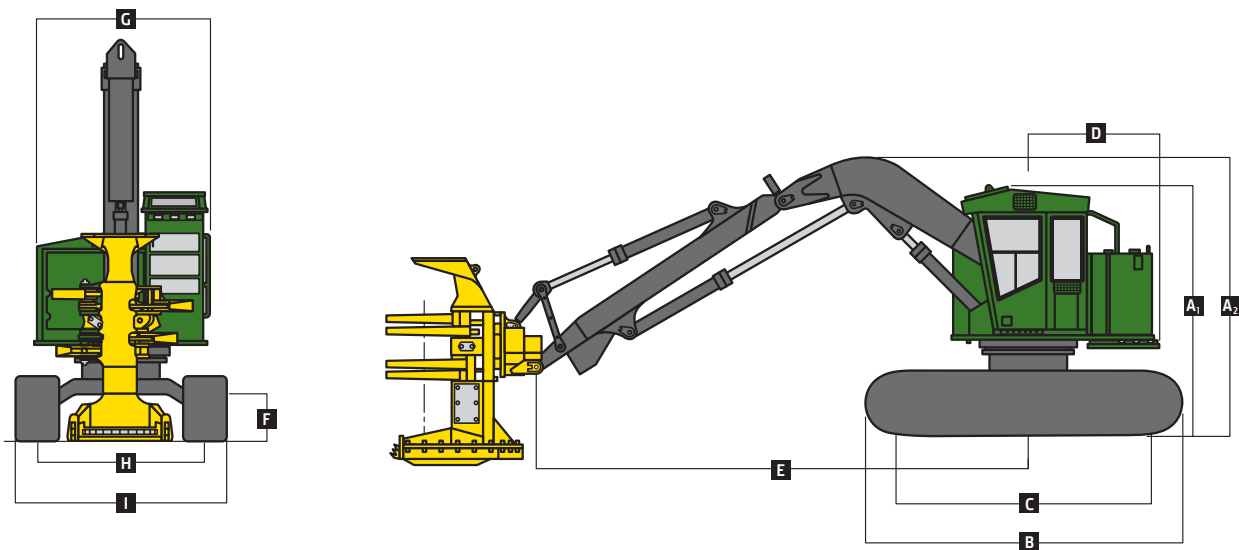

759J Track Feller Buncher

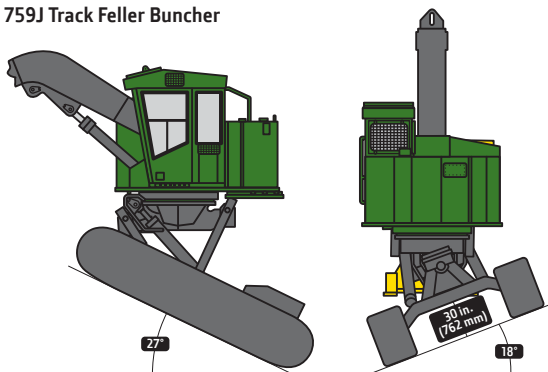

759J Undercarriage Leveling Mechanism

Forward	27 deg.
Rear	10 deg.
Side to Side	18 deg.

Machine not exactly as shown. Illustrations for dimensioning purposes only.

903K / 909K / 953K / 959K

Engine	903K		909K		953K		959K	
Manufacturer and Model	John Deere PowerTech™ Plus 6090H							
Non-Road Emission Standards	EPA Tier 3/EU Stage IIIA							
Displacement	9.0 L (549 cu. in.)		9.0 L (549 cu. in.)		9.0 L (549 cu. in.)		9.0 L (549 cu. in.)	
Standard Engine:								
Peak Power at 1,900 rpm	224 kW (300 hp)		224 kW (300 hp)		246 kW (330 hp)		246 kW (330 hp)	
Net Power (ISO 9249) at 2,000 rpm	199 kW (267 hp)		199 kW (267 hp)		214 kW (286 hp)		214 kW (286 hp)	
Net Peak Torque at 1,500 rpm	1270 Nm (937 lb.-ft.)		1270 Nm (937 lb.-ft.)		1392 Nm (1,027 lb.-ft.)		1392 Nm (1,027 lb.-ft.)	
Optional Engine:								
Peak Power at 1,900 rpm	246 kW (330 hp)		246 kW (330 hp)		N/A		N/A	
Net Power (ISO 9249) at 2,000 rpm	214 kW (286 hp)		214 kW (286 hp)		N/A		N/A	
Net Peak Torque at 1,500 rpm	1392 Nm (1,027 lb.-ft.)		1392 Nm (1,027 lb.-ft.)		N/A		N/A	
Fuel Tank	1117 L (295 gal.)		1117 L (295 gal.)		1117 L (295 gal.)		1117 L (295 gal.)	
Cooling	903K / 909K / 953K / 959K							
Fan Type	Suction type, hydraulically driven, variable speed, reversing							
Powertrain	903K		909K		953K		959K	
Undercarriage	U7 (standard)	U6 (optional)	HD (standard)	ExD (optional)	Standard		ExD (standard)	
Travel Speed, Forward and Reverse:								
High	4.2 km/h (2.6 mph)	5.0 km/h (3.1 mph)	4.2 km/h (2.6 mph)	3.6 km/h (2.2 mph)	4.2 km/h (2.6 mph)		3.6 km/h (2.2 mph)	
Low	2.0 km/h (1.2 mph)	2.6 km/h (1.6 mph)	2.0 km/h (1.2 mph)	1.7 km/h (1.0 mph)	2.0 km/h (1.2 mph)		1.7 km/h (1.0 mph)	
Tractive Effort	331 kN (74,300 lbf)	248 kN (55,700 lbf)	331 kN (74,300 lbf)	384 kN (86,300 lbf)	331 kN (74,300 lbf)		384 kN (86,300 lbf)	
Travel Brakes	Sealed, wet, multi-disc, automatic application, integral with track-drive gearboxes							
Hydraulics	903K / 909K / 953K / 959K							
	Closed center, load sense, pressure compensated							
Main Pump:	Variable-displacement, axial-piston							
Maximum Rated Flow	475 L/min. (125 gpm)							
Continuous Saw Pump:	Dedicated variable-displacement, axial-piston							
Maximum Rated Flow	114 L/min. (30 gpm)							
Attachment Pump:	Dedicated variable-displacement, axial-piston							
Maximum Rated Flow	120 L/min. (32 gpm)							
Oil Filtration	2 main return filters, 10-micron return with bypass and one case drain strainer, 25 micron							
Electrical	903K		909K		953K		959K	
Voltage	24 volt		24 volt		24 volt		24 volt	
Batteries	2 x 12 volt		2 x 12 volt		2 x 12 volt		2 x 12 volt	
Alternator Rating	100 amp standard / 130 amp optional		100 amp standard / 130 amp optional		100 amp standard / 130 amp optional		100 amp standard / 130 amp optional	
Work Lights	Halogen (9 flood and 5 spot)		Halogen (10 flood and 5 spot)		Halogen (9 flood and 5 spot)		Halogen (10 flood and 5 spot)	
Service Lights	Halogen (3)		Halogen (3)		Halogen (3)		Halogen (3)	
Undercarriage								
Undercarriage	U7 (standard)	U6 (optional)	HD (standard) / ExD (optional)		Standard		ExD (standard)	
Track Gauge	2560 mm (101 in.)	2560 mm (101 in.)	2718 mm (107 in.)		2560 mm (101 in.)		2718 mm (107 in.)	
Track Shoes, Single-Bar Grouser, Clipped Corner, Heavy Duty, Open Center	610 mm (24.0 in.)	610 mm (24.0 in.)	610 mm (24.0 in.)		610 mm (24.0 in.)		610 mm (24.0 in.)	
Track Chain, Heavy Duty	215.9 mm (8.5 in.)	203.2 mm (8.0 in.)	215.9 mm (8.5 in.)		215.9 mm (8.5 in.)		215.9 mm (8.5 in.)	
Carrier Slides (per side)	2 bolt-on		2 bolt-on		2 bolt-on		2 bolt-on	
Shoes (per side)	45		47		45		47	
Track Rollers (per side)	9 (tractor type)		10 (tractor type)		9 (tractor type)		10 (tractor type)	
Track Guides, Integral, Thick High-Abrasion-Resistant Material	25 mm (1.0 in.)		25 mm (1.0 in.)		25 mm (1.0 in.)		25 mm (1.0 in.)	
Ground Contact Area (with standard shoe)	4.9 m ² (7,541 sq. in.)		4.6 m ² (7,053 sq. in.)		5.1 m ² (7,957 sq. in.)		4.9 m ² (7,541 sq. in.)	
Track Adjustment	Hydraulic		Hydraulic		Hydraulic		Hydraulic	

Specifications are subject to change without notice.

Swing Mechanism	903K	909K	953K	959K
Rotation (continuous)	360 deg.	360 deg.	360 deg.	360 deg.
Swing Speed (maximum)	6.7 rpm	6.7 rpm	5.0 rpm	5.0 rpm
Swing Torque	70 503 Nm (52,000 lb.-ft.)	70 503 Nm (52,000 lb.-ft.)	99 246 Nm (73,200 lb.-ft.)	99 246 Nm (73,200 lb.-ft.)
Swing Brake	Sealed, wet, multi-disc	Sealed, wet, multi-disc	Sealed, wet, multi-disc	Sealed, wet, multi-disc

Ground Pressure Data						
SAE J1309 (less attachment) / Undercarriage	U7 (standard)	U6 (optional)	HD (standard)	ExD (optional)	Standard	ExD (standard)
Double Grouser, Heavy Duty:						
610 mm (24 in.)	59.7 kPa (8.7 psi)	59.3 kPa (8.6 psi)	67.9 kPa (9.8 psi)	68.6 kPa (9.9 psi)	63.2 kPa (9.2 psi)	70.6 kPa (10.2 psi)
760 mm (30 in.)	48.8 kPa (7.1 psi)	48.2 kPa (7.0 psi)	—	—	51.6 kPa (7.5 psi)	—
Single Grouser, Clipped Corner, Heavy Duty:						
610 mm (24 in.)	59.8 kPa (8.7 psi)	58.8 kPa (8.5 psi)	68.0 kPa (9.9 psi)	68.4 kPa (9.9 psi)	63.2 kPa (9.2 psi)	70.4 kPa (10.2 psi)
711 mm (28 in.)	52.0 kPa (7.5 psi)	51.0 kPa (7.4 psi)	59.0 kPa (8.6 psi)	59.4 kPa (8.6 psi)	54.9 kPa (8.0 psi)	61.0 kPa (8.8 psi)
Triple Grouser, Heavy Duty (for soft terrain only):						
914 mm (36 in.)	—	41.4 kPa (6.0 psi)	—	—	—	—

Operating Weight						
Includes standard equipment, half-full fuel tank, all fluids, 80-kg (175 lb.) operator (less attachment)						
Undercarriage	U7 (standard)	U6 (optional)	HD (standard)	ExD (optional)	Standard	ExD (standard)
Approximate Weight	29 630 kg (65,330 lb.)	27 510 kg (60,650 lb.)	35 570 kg (78,430 lb.)	35 930 kg (79,220 lb.)	31 280 kg (69,100 lb.)	36 960 kg (81,500 lb.)

Attachment Information		903K / 909K	903K / 909K	953K	959K
Attachment		FS22B	FR22B	FR24B	FR24B
Maximum Cutting Capacity		559 mm (22.0 in.)	559 mm (22.0 in.)	622 mm (24.5 in.)	622 mm (24.5 in.)
Maximum Accumulation Capacity		0.48 m ² (5.2 sq. ft.)	0.48 m ² (5.2 sq. ft.)	0.60 m ² (6.4 sq. ft.)	0.60 m ² (6.4 sq. ft.)
Opening at Front of Housing		1280 mm (50.4 in.)	1280 mm (50.4 in.)	1372 mm (54.0 in.)	1372 mm (54.0 in.)
Blade Diameter		1422 mm (56 in.)	1422 mm (56 in.)	1549 mm (61 in.)	1549 mm (61 in.)
Number of Teeth		18	18	20	20
Wrist		30 deg.	312 deg.	310 deg.	310 deg.
Width at Saw Housing		1620 mm (63.8 in.)	1620 mm (63.8 in.)	1737 mm (68.4 in.)	1737 mm (68.4 in.)
Height		3068 mm (120.8 in.)	3068 mm (120.8 in.)	3068 mm (120.8 in.)	3068 mm (120.8 in.)
Weight (including adapter and wrist)		3310 kg (7,300 lb.)	3775 kg (8,320 lb.)	3950 kg (8,700 lb.)	3950 kg (8,700 lb.)

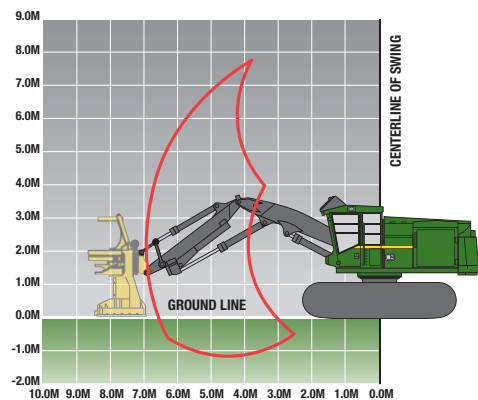

903K / 909K Track Feller Buncher

Standard Boom Performance		903K	909K
Attachment		Standard Crank/Link Boom w/ FR22B	Optional Crank/Link Long Boom w/ Typical Attachment, 1680 mm (66 in.) to Saw Tip
Lift Capacity (bare pin):			
At Full Reach		6210 kg (13,700 lb.)	4850 kg (10,700 lb.)
At 6.1 m (20 ft. 0 in.)		7130 kg (15,720 lb.)	7130 kg (15,720 lb.)
Reach (to tip of saw blade):			
Maximum		8.48 m (27 ft. 10 in.)	9.83 m (32 ft. 3 in.)
Minimum		5.44 m (17 ft. 10 in.)	5.11 m (16 ft. 9 in.)
Cutting Swath		3.05 m (10 ft. 0 in.)	4.72 m (15 ft. 6 in.)

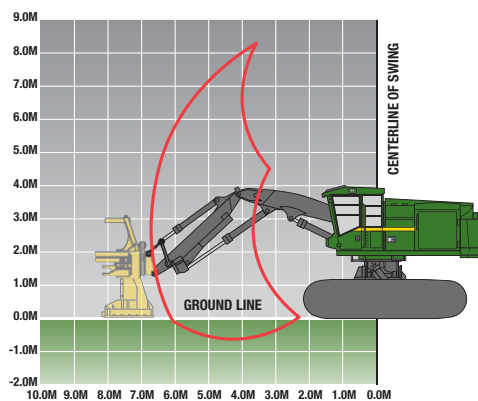

953K / 959K Track Feller Buncher

Standard Boom Performance		953K / 959K
Attachment		Standard Crank/Link Boom w/ FR24B
Lift Capacity (bare pin):		
At Full Reach		8160 kg (18,000 lb.)
At 6.1 m (20 ft. 0 in.)		9325 kg (20,560 lb.)
Reach (to tip of saw blade):		
Maximum		8.53 m (28 ft. 0 in.)
Minimum		5.49 m (18 ft. 0 in.)
Cutting Swath		3.05 m (10 ft. 0 in.)

Machine not exactly as shown. Illustrations for dimensioning purposes only.

Machine Dimensions	903K	909K	953K	959K		
Undercarriage	U7 (standard)	U6 (optional)	HD (standard)	ExD (optional)	Standard	ExD (standard)
A Overall Height:						
Top of Cab without Skylight	3.53 m (11 ft. 7 in.)	3.48 m (11 ft. 5 in.)	—	—	3.53 m (11 ft. 7 in.)	—
Top of Cab with Skylight	3.81 m (12 ft. 6 in.)	3.76 m (12 ft. 4 in.)	4.02 m (13 ft. 3 in.)	4.02 m (13 ft. 3 in.)	3.81 m (12 ft. 6 in.)	4.02 m (13 ft. 3 in.)
Top of Boom	4.01 m (13 ft. 2 in.)	3.96 m (13 ft. 0 in.)	4.19 m (13 ft. 9 in.)	4.19 m (13 ft. 9 in.)	4.01 m (13 ft. 2 in.)	4.19 m (13 ft. 9 in.)
B Overall Track Length	4.69 m (15 ft. 5 in.)	4.41 m (14 ft. 6 in.)	4.92 m (16 ft. 2 in.)	4.92 m (16 ft. 2 in.)	4.69 m (15 ft. 5 in.)	4.92 m (16 ft. 2 in.)
C Track Length (idler to sprocket center)	3.62 m (11 ft. 10 in.)	3.37 m (11 ft. 1 in.)	3.83 m (12 ft. 7 in.)	3.83 m (12 ft. 7 in.)	3.62 m (11 ft. 10 in.)	3.83 m (12 ft. 7 in.)
D Tail Swing (from swing center):						
Standard Counterweight	3.05 m (10 ft. 0 in.)	3.05 m (10 ft. 0 in.)	3.05 m (10 ft. 0 in.)	3.05 m (10 ft. 0 in.)	3.23 m (10 ft. 7 in.)	3.23 m (10 ft. 7 in.)
Optional Counterweight	3.23 m (10 ft. 7 in.)	3.23 m (10 ft. 7 in.)	—	—	—	—
E Boom Reach (to attachment pin) — Standard Crank/Link Boom:						
Maximum	6.71 m (22 ft. 0 in.)	6.71 m (22 ft. 0 in.)	6.71 m (22 ft. 0 in.)	6.71 m (22 ft. 0 in.)	8.53 m (28 ft. 0 in.)	6.71 m (22 ft. 0 in.)
Minimum	3.66 m (12 ft. 0 in.)	3.66 m (12 ft. 0 in.)	3.66 m (12 ft. 0 in.)	3.66 m (12 ft. 0 in.)	5.49 m (18 ft. 0 in.)	3.66 m (12 ft. 0 in.)
Cutting Swath	3.05 m (10 ft. 0 in.)	3.05 m (10 ft. 0 in.)	3.05 m (10 ft. 0 in.)	3.05 m (10 ft. 0 in.)	3.05 m (10 ft. 0 in.)	3.05 m (10 ft. 0 in.)
E' Boom Reach (to attachment pin) — Optional Crank/Link Long Boom:						
Maximum Reach	8.15 m (26 ft. 9 in.)	8.15 m (26 ft. 9 in.)	—	—	—	—
Minimum Reach	3.43 m (11 ft. 3 in.)	3.43 m (11 ft. 3 in.)	—	—	—	—
Cutting Swath	4.72 m (15 ft. 6 in.)	4.72 m (15 ft. 6 in.)	—	—	—	—
F Ground Clearance:						
Single Grouser	735 mm (29 in.)	735 mm (29 in.)	769 mm (30 in.)	769 mm (30 in.)	735 mm (29 in.)	769 mm (30 in.)
Double Grouser	711 mm (28 in.)	711 mm (28 in.)	735 mm (29 in.)	735 mm (29 in.)	711 mm (28 in.)	735 mm (29 in.)
G Upperstructure Width:						
Without Optional Walkway	3.05 m (10 ft. 0 in.)	3.05 m (10 ft. 0 in.)	—	—	3.05 m (10 ft. 0 in.)	—
With Optional Walkway	3.20 m (10 ft. 6 in.)	3.20 m (10 ft. 6 in.)	—	—	3.20 m (10 ft. 6 in.)	—
With Standard Walkway	—	—	3.20 m (10 ft. 6 in.)	3.20 m (10 ft. 6 in.)	—	3.20 m (10 ft. 6 in.)
H Track Gauge	2.56 m (8 ft. 5 in.)	2.56 m (8 ft. 5 in.)	2.72 m (8 ft. 11 in.)	2.72 m (8 ft. 11 in.)	2.56 m (8 ft. 5 in.)	2.72 m (8 ft. 11 in.)
I Width Over Tracks:						
610-mm (24 in.) Track Shoes	3.17 m (10 ft. 5 in.)	3.17 m (10 ft. 5 in.)	3.33 m (10 ft. 11 in.)	3.33 m (10 ft. 11 in.)	3.17 m (10 ft. 5 in.)	3.33 m (10 ft. 11 in.)
711-mm (28 in.) Track Shoes	3.27 m (10 ft. 9 in.)	3.27 m (10 ft. 9 in.)	3.43 m (11 ft. 3 in.)	3.43 m (11 ft. 3 in.)	3.27 m (10 ft. 9 in.)	3.43 m (11 ft. 3 in.)
760-mm (30 in.) Track Shoes	3.32 m (10 ft. 11 in.)	3.32 m (10 ft. 11 in.)	—	—	3.32 m (10 ft. 11 in.)	—
914-mm (36 in.) Track Shoes	—	3.47 m (11 ft. 5 in.)	—	—	—	—

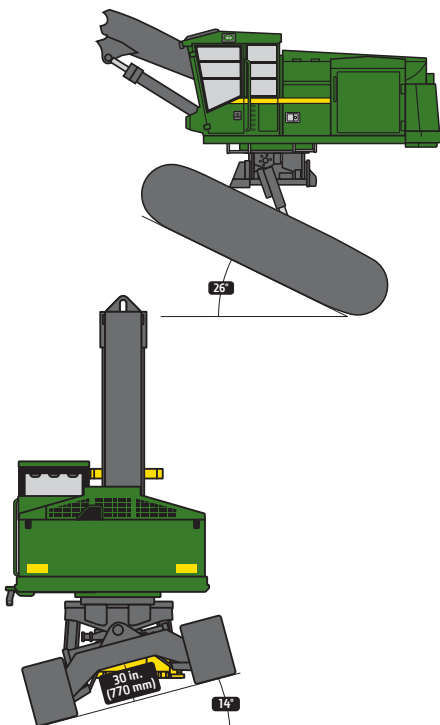

909K / 959K Undercarriage Leveling Mechanism

Forward	26 deg.
Rear	7 deg.
Side to Side	14 deg.

903K / 953K Track Feller Buncher

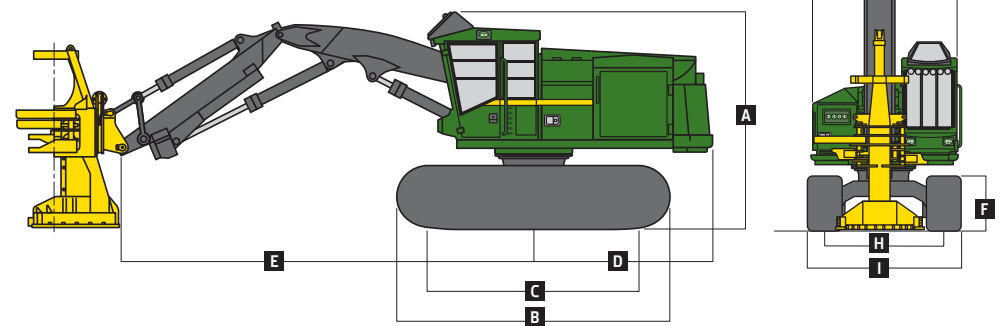

909K / 959K Track Feller Buncher

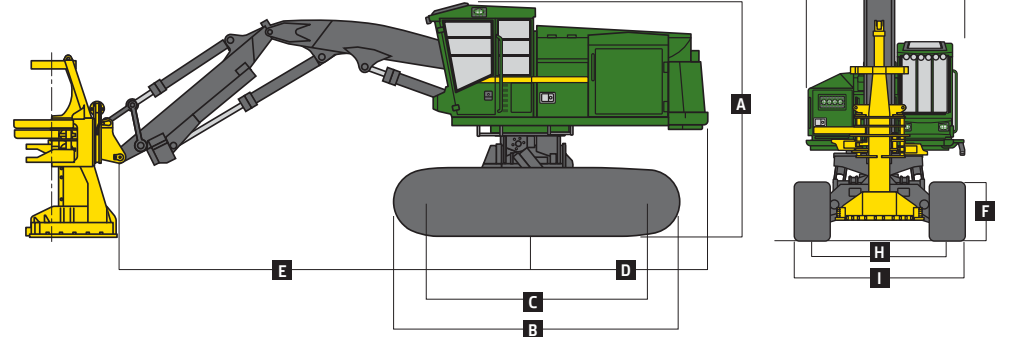

Specifications are subject to change without notice.



IT'S ABOUT TIME THE ODDS WEIGHED IN YOUR FAVOR.

We know the forest stacks the odds against you. But the new 753J features a larger undercarriage option that is tipping the scales to your advantage. This next-size-up U7 carrier adds over 5000 pounds of stabilizing force and an 11" longer track that eats up rocky, hilly terrain. Plus, a lower center of gravity makes it easy to gather a full head load. All in a machine designed not to quit. So no matter how steep the challenge, you're always on solid ground. For more info, see your dealer today, or call 1-800-503-3373. At John Deere, We're For Loggers.



JohnDeere.com/tfb