



NEW HOLLAND

C227 C232 C238

200 SERIES COMPACT TRACK LOADERS



200 SERIES

Preliminary Brochure



BUILT AROUND YOU

Built Around You

Introducing the new 200 Series compact track loaders. **With five years in the making, they're bigger, badder and better!**

New Holland engineers used input from hundreds of customers to design our new line of compact track loaders. Designed from the ground up, these machines were built around you. No matter what your line of work – agriculture, landscaping or construction – you'll work faster, smarter and more profitably with our new compact track loaders.

- New Holland's patented vertical lift Super Boom® design has best-in-class forward dump height and reach. It's more efficient to load materials to the center of the truck.
- Our industry leading bucket breakout force and dump angle provide fast cycle times and improve productivity.
- The rigid undercarriage design is simple, yet rugged, giving you a stable ride over rough working surfaces. Plus, with fewer moving parts than a suspension track system, it's easier to maintain.
- Need more room? We have one of the widest, most comfortable cabs in the industry, giving you more head and foot room, and offering twice the visibility in critical zones. Better visibility allows safe and efficient movement around the worksite.
- Comfortable operators get more work done. Just a few new convenience features include: keyless start, a Glide Ride option, available heated or air-ride seat and a self-leveling bucket feature.
- The overall width has been reduced from 84 inches to 78 inches on the C232 and C238 units equipped with the 17.7 inch tracks. This change makes it easy to transport on standard trailers.
- Daily maintenance just got easier. Our ground-level service checkpoints are easy to access and grouped together. Plus, the new flip-top cab tilts forward for complete component access.

With over 55 attachments available for the new 200 Series compact track loaders, these machines are multi-task masters! Whether you work in agriculture, landscaping or construction, New Holland delivers the equipment to get the job done right.



Compact Track Loader Specifications

RADIAL LIFT (C227)

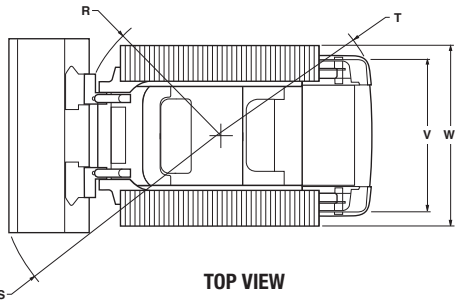
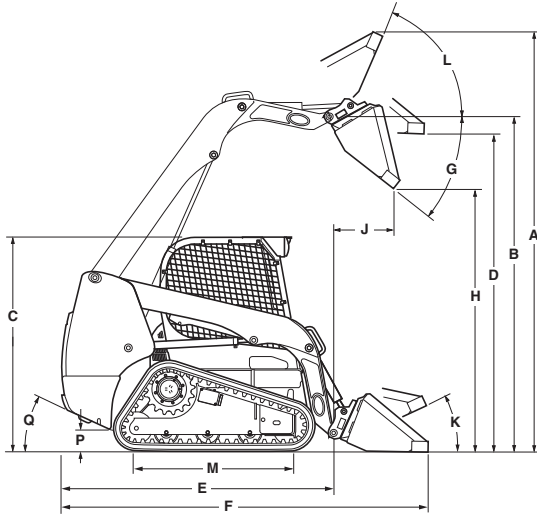

VERTICAL LIFT (C232 & C238)

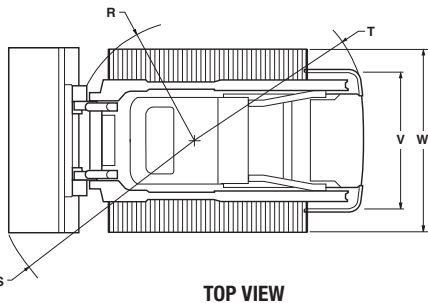
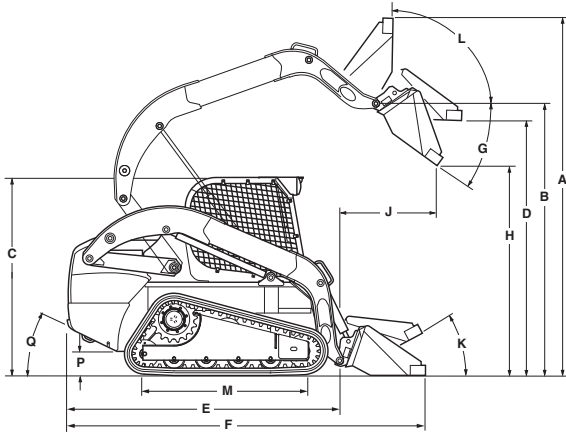

DIMENSIONS	C227	C232	C238
Overall operating height			
A. with foundry/excavating bucket short lip, in (mm)	154.3 (3920)	161.3 (4096)	161.3 (4096)
A. with low profile/standard lip bucket, in (mm)	158.3 (4020)	165.3 (4199)	165.3 (4199)
A. with low profile extended/long lip bucket, in (mm)	163.2 (4146)	170.4 (4327)	170.4 (4327)
Height to			
B. Bucket hinge pin, in (mm)	123 (3124)	131.1 (3330)	131.1 (3330)
C. Top of ROPS, in (mm)	78.7 (1998)	80.4 (2043)	80.4 (2043)
D. Bottom of level bucket, fully raised, in (mm)	116.1 (2950)	124.2 (3155)	124.2 (3155)
Overall length			
E. without attachment with coupler, in (mm)	105.1 (2669)	117.8 (2993)	117.6 (2986)
F. with foundry excavation bucket on ground, in (mm)	129.6 (3292)	142.9 (3631)	142.7 (3624)
F. with low profile bucket, in (mm)	133.7 (3397)	147 (3734)	146.7 (3727)
F. with low profile extended bucket, in (mm)	138.8 (3525)	152.1 (3863)	151.8 (3856)
Dump			
G. Dump angle, degrees	40	55	55
H. Dump height			
with foundry/excavating bucket short lip, in (mm)	98.2 (2495)	104.5 (2655)	104.5 (2655)
with low profile/standard lip bucket, in (mm)	95.6 (2428)	102.2 (2596)	102.2 (2596)
J. Dump reach (max height), in (mm)	22.3 (568)	34.0 (864)	34.0 (864)
Maximum attachment rollback			
K. Bucket on ground, degrees	31	33	33
L. Bucket at full height, degrees	99	85	85
Track and Clearance			
M. Track on ground, in (mm)	56.7 (1441)	63.1 (1602)	63.1 (1602)
P. Ground clearance (bottom of belly pan), in (mm)	8 (203)	9.5 (243)	9.5 (243)
Q. Angle of departure, degrees	32	32	32
Clearance circle			
R. without bucket, in (mm)	50.7 (1289)	1428 (56.2)	1428 (56.2)
S. with foundry bucket in carry position, in (mm)	79.9 (2031)	84.8 (2155)	84.8 (2155)
	w/72" bucket	w/78" bucket	w/78" bucket
S. with low profile bucket on ground, in (mm)	83.1 (2112)	88.4 (2246)	88.4 (2246)
	w/72" bucket	w/78" bucket	w/78" bucket
S. with extended low profile on ground, in (mm)	87.7 (2228)	92.6 (2352)	92.6 (2352)
	w/72" bucket	w/78" bucket	w/78" bucket
T. Clearance circle rear, in (mm)	62.9 (1599)	70.7 (1796)	70.4 (1789)
V. Track gauge, in (mm)	53.4 (1356)	58.3 (1480)	58.3 (1480)
W. Overall width, in (mm)	65.9 (1676)	76 (1930)	76 (1930)

Compact Track Loader Specifications

ENGINE	C227	C232	C238
Manufacturer/model	FPT / F5C E9454	FPT / F5C E9454	FPT / F5C E9454
Type	Diesel 4-stroke, turbo, D.I.	Diesel 4-stroke, turbo, D.I.	Diesel 4-stroke, turbo, D.I.
Cylinder	4	4	4
Bore/stroke, in (mm)	3.9 x 4.1 (99 x 104)	3.9 x 4.1 (99 x 104)	3.9 x 4.1 (99 x 104)
Displacement, in ³ (L)	195 (3.2)	195 (3.2)	195 (3.2)
Fuel injection	Direct	Direct	Direct
Fuel	#2 diesel	#2 diesel	#2 diesel
Fuel filter	In-line w/ water separator	In-line w/ water separator	In-line w/ water separator
Air intake	Turbocharged w/ external EGR	Turbocharged w/ external EGR	Turbocharged w/ external EGR
Cooling	Liquid	Liquid	Liquid
Engine speeds			
High idle - no load, rpm	2675 +/- 75	2675 +/- 75	2675 +/- 75
Rated - full load, rpm	2500	2500	2500
Low idle, rpm	1075 +/- 75	1075 +/- 75	1075 +/- 75
Horsepower per SAE J1349			
Gross hp (kW)	74 (55) @ 2500 rpm	82 (61) @ 2500 rpm	90 (67) @ 2500 rpm
Net hp (kW)	70 (52) @ 2500 rpm	76 (57) @ 2500 rpm	84 (63) @ 2500 rpm
Peak torque, lb-ft (N•m)	203 (275) @ 1400 rpm	225 (305) @ 1400 rpm	251 (340) @ 1400 rpm

POWER TRAIN	C227	C232	C238
Drive pump electro hydraulic			
Pump to engine ratio	1:1	1:1	1:1
Displacement, in ³ (cc)	2.81 (46)	2.81 (46)	2.81 (46)
Flow, gpm (Lpm)	30.4 (115)	30.4 (115)	30.4 (115)
Charge pressure, psi (bar)	363 (25)	363 (25)	363 (25)
System relief, psi (bar)	5220 (360)	5220 (360)	5220 (360)
Control	Electro hydraulic	Electro hydraulic	Electro hydraulic
Drive motors			
Effective Max displacement, in ³ (cc)	67 (1098)	67 (1098)	67 (1098)
Effective Displacement opt high speed, in ³ (cc)	43.6 (714)	43.6 (714)	43.6 (714)
Speed @ high idle engine rpm	105	105	105
Speed @ optional high speed, rpm	161	161	161
Torque @ max displ. and relief pressure, lb-ft (N•m)	4635 (6283)	4635 (6283)	4635 (6283)
Travel speed			
Low range, mph (km/h)	5.8 (9.3)	5.8 (9.3)	5.8 (9.3)
High range (optional), mph (km/h)	8.3 (13.4)	8.3 (13.4)	8.3 (13.4)
Final drive	Planetary Reduction	Planetary Reduction	Planetary Reduction
Parking brake			
Type	Spring applied, hydraulic release disc	Spring applied, hydraulic release disc	Spring applied, hydraulic release disc
Engagement	Depress on/off brake button on instrument panel, disconnect lapbelt, get off seat, or stop engine	Depress on/off brake button on instrument panel, disconnect lapbelt, get off seat, or stop engine	Depress on/off brake button on instrument panel, disconnect lapbelt, get off seat, or stop engine

UNDERCARRIAGE	C227	C232	C238
System	High drive offset tread pattern	High drive offset tread pattern	High drive offset tread pattern
Idlers / rollers per side	2/3	2/4	2/4
Ground pressure			
PSI (with 12.6", 320 mm belt)	5.7	NA	NA
PSI (with 15.7", 400 mm belt)	NA	4.8	5.0
PSI (with 17.7", 450 mm belt)	NA	4.3	4.5

Compact Track Loader Specifications

HYDRAULIC SYSTEM	C227	C232	C238
Pumps			
Type	Gear	Gear	Gear
Displacement standard aux., in ³ (cc)	2.08 (34.1)	2.08 (34.1)	2.08 (34.1)
Displacement high flow aux., in ³ (cc)	.76 (12.5)	1.12 (18.3)	1.12 (18.3)
Pump flow, gpm (Lpm)	22.5 (85)	22.5 (85)	22.5 (85)
Optional high flow, gpm (Lpm)	30.7 (116)	34.6 (131)	34.6 (131)
Loader control valve			
Type	3 spool / open center / series	3 spool / open center / series	3 spool / open center / series
Relief pressure, psi (bar)	3000 (207)	3000 (207)	3000 (207)
Hydraulic filter	6 micron / spin on	6 micron / spin on	6 micron / spin on

CYLINDERS	C227	C232	C238
Lift cylinder			
Bore diameter, in (mm)	2.5 (64)	2.5 (64)	2.5 (64)
Rod diameter, in (mm)	1.75 (45)	1.75 (45)	1.75 (45)
Stroke in, in (mm)	31.7 (805)	33.5 (852)	33.5 (852)
Closed length, in (mm)	45.6 (1158.0)	46.9 (1192)	46.9 (1192)
Bucket cylinders			
Bore diameter, in (mm)	2.75 (70)	3.0 (76)	3.0 (76)
Rod diameter, in (mm)	1.375 (35)	1.5 (38)	1.5 (38)
Stroke, in (mm)	16.14 (410)	16.14 (410)	16.14 (410)
Closed length, in (mm)	24 (610)	24 (610)	24 (610)

WEIGHTS	C227	C232	C238
Operating weight, lbs (kg)	8200 (3720)	9630 (4370)	10,100 (4581)
Shipping weight, lbs (kg)	7900 (3585)	9300 (4220)	9765 (4430)

SERVICE CAPACITIES	C227	C232	C238
Fuel tank, gal (L)	20 (75.5)	25.5 (96.5)	25.5 (96.5)
Engine oil with filter, qt (L)	10 (9.5)	10 (9.5)	10 (9.5)
Hydraulic system			
Reservoir, gal (L)	5.3 (20)	6 (22.75)	6 (22.75)

PERFORMANCE SPECS	C227	C232	C238
Rated operating load			
50% tip, lbs (kg)	2700 (1225)	3200 (1451)	3800 (1723)
35% tip, lbs (kg)	1890 (859)	2240 (1018)	2660 (1209)
Tipping load, lbs (kg)	5400 (2449)	6400 (2902)	7600 (3447)
Breakout forces			
Lift cylinder, lbs (kN)	6125 (27.3)	4940 (22)	4940 (22)
Bucket cylinder, lbs (kN)	7145 (31.8)	8585 (38.2)	8585 (38.2)
Cycle times			
Raise, sec	3.7	3.9	3.9
Lower, sec	1.9	2.5	2.5
Dump, sec	2.3	2.7	2.7
Roll back, sec	1.7	2.0	2.0

For all Dimensions and Performance Metrics, unless otherwise specified:

C227 – Equipped with 175 lb operator, 72” Dirt & Foundry Bucket with 12.6 (320 mm) track belt

C232 – Equipped with 175 lb operator, 78” Heavy Duty Bucket and 17.7 (450 mm) track belt

C238 – Equipped with 175 lb operator, 78” Heavy Duty Bucket and 17.7 (450 mm) track belt

World Class Products Demand World Class Dealers

The purchase of a New Holland machine is just the beginning of our relationship together. Consider your experienced New Holland Construction Equipment dealer as your local partner in productivity. Assistance in selecting the right model for your operation and developing an affordable leasing or financing plan through CNH Capital are just a few advantages your local dealer can provide.

Your New Holland dealer's full service capabilities bring you responsive support with genuine New Holland parts and all makes coverage. More importantly, we are there wherever and whenever you need us with our fully equipped service vehicles. From customized maintenance programs to professional operator and technical training, our factory-trained service and parts experts are there to assist you with any of your equipment support needs.

Your business deserves nothing less than world class product, supported by a world class business partner. That's your New Holland Construction Equipment dealer—your partner in productivity.



New Holland Construction
700 State Street
Racine, WI 53402
866-726-3396 Toll Free
262-636-6011

New Holland Construction Equipment is backed with a **1-Year/Unlimited Hour Standard Warranty.**

Design, materials and/or specifications are subject to change without notice and without liability therefor. Specifications are applicable to units sold in Canada, the United States, its territories and possessions, and may vary outside these areas.

© 2010 CNH America LLC. All rights reserved. New Holland is a trademark of CNH America LLC. Any trademarks referred to herein, in association with goods and/or services of companies other than CNH America LLC, are the property of those respective companies.



Safety begins with a thorough understanding of the equipment. Always make sure you and your operators read the Operator's Manual before using the equipment. Pay close attention to all safety and operating decals and never operate machinery without all shields, protective devices and structures in place.

Stock #NHC201011CTLPrelim • PRINTED IN U.S.A.

 Printed on recycled paper

www.newholland.com