

Series II Model Tractors

Series II Super Wildcat 1974 - 1975



MK98E017

MODEL ST200

ENGINE: Cat 3150 V8 @ 200 HP (first production)
Cat 3208 V8 @ 200 HP (later production)

AXLE: Clark (Model 19850) or Dana (Model A-235) outboard planetary

CLUTCH: Spicer 14 inch dual plate

HYDRAULIC SYSTEM: Open center, Engine crankshaft driven 2-stage gear pump (steering and remotes)

TRANSFER CASE: Swinging type, 3-shaft drop, with tapered roller bearings and oil cooled, 1:1 Gear Ratio

TRANSMISSION: Dana-Spicer 1010 mechanical 10-speed, oil cooled.

Note: *The transmission and transfer case on this model share a central oil sump.*

PARTS CATALOG P/N: 37-085 (4-81)

Serial No. Range By Model/Year

Year	Beginning S/N
1974	9001
1975	9074

MODEL RC 200

ENGINE: Cat 3150 V8 @ 200 HP (first production)
Cat 3208 V8 @ 200 HP (later production)

AXLE: Adjustable Bar Style, 30.8 O/A Ratio

CLUTCH: Spicer 14 inch dual plate

HYDRAULIC SYSTEM: Open center, Engine crankshaft driven 2-stage gear pump (steering and remotes)

TRANSFER CASE: Swinging type, 3-shaft drop with tapered roller bearings and oil cooled, 1:1 Gear Ratio

TRANSMISSION: Fuller TA4510 mechanical 10-speed, oil cooled.

Historical Data

Note: *The transmission and transfer case on this model share a central oil sump.*

PARTS CATALOG P/N: 37-085 (4-81)

Serial No. Range By Model/Year

Year	Beginning S/N
1974	50001
1975	50043

Series II Bearcat 1974 - 1976



MK98E023

MODEL ST 225

ENGINE: Cat 3160 V8 @ 225 HP (first production)
Cat 3208 V8 @ 210 HP (later production)

AXLE: Clark (Model 19850) or Dana (Model A-235) outboard planetary

CLUTCH: Spicer 14 inch dual plate

HYDRAULIC SYSTEM: Open center, Engine crankshaft driven 2-stage gear pump (steering and remotes)

TRANSFER CASE: Swinging type, 3-shaft drop with tapered roller bearings and oil cooled, 1:1 Gear Ratio

TRANSMISSION: Dana-Spicer 1010 mechanical 10-speed, oil cooled.

Note: *The transmission and transfer case on this model share a central oil sump.*

PARTS CATALOG P/N: 37-085 (4-81)

Serial No. Range By Model/Year

Year	Beginning S/N
1974	3001
1975	3402
1976	3772

MODEL RC 220

ENGINE: Cat 3160 V8 @ 225 HP (first production)
Cat 3208 V8 @ 210 HP (later production)

AXLE: Adjustable Bar Style, 30.8 O/A Ratio

CLUTCH: Spicer 14 inch dual plate

HYDRAULIC SYSTEM: Open center, Engine crankshaft driven 2-stage gear pump (steering and remotes)

TRANSFER CASE: Swinging type, 3-shaft drop with tapered roller bearings and oil cooled, 1:1 Gear Ratio

TRANSMISSION: Fuller TA4510 or Dana-Spicer 1010 mechanical 10-speed, oil cooled.

Note: *The transmission and transfer case on this model share a central oil sump.*

PARTS CATALOG P/N: 37-085 (4-81)

Serial No. Range By Model/Year

Year	Beginning S/N
1974	55001
1975	55087

Series II Super Wildcat & Bearcat (Cat 3100-V8 or 3208-V8)

BELT P/Ns

Engine Fan:	06-019
Alternator:	06-019 (55") (SWC, BSN 3258 & BC BSN 9062)
	06-076 (57" on some w/5" pulley on alt)
	06-1464 (ASN above)
A/C Compressor:	06-1428 (w/3100 Series Engine)
	06-1451 (w/3208 Series Engine)

FILTER P/Ns

Engine Air (Primary):	09-026S1 (std life)
	09-026 (ext. life)
Engine Air (Safety):	09-027
Cab Air:	64-084
Engine Oil:	28-006
Engine Fuel:	28-007 (w/3100 Series Engine)
	28-025 (w/3208 Series Engine)
Transmission/Transfer Case:	18-502
Hydraulic:	18-498
Hydraulic Tank Relief:	18-1633

Series II Cougar 1974 - 1976



MK98E021

MODEL ST 300

ENGINE: Cat 3306T In-Line 6 cyl

AXLE: Clark (Model D33300) or STEIGER/Raba K598 00/10 outboard planetary

CLUTCH: Spicer-HD 14 inch dual plate

HYDRAULIC SYSTEM: Open center, 3-spool remote valve (std), 2-stage gear pump (steering and remotes)

TRANSFER CASE: Swinging type, oil cooled, tapered roller bearings with 1:1 Gear Ratio

TRANSMISSION: Spicer SST 1010 mechanical 10-speed, oil cooled.

Note: *The transmission and transfer case on this model share a central oil sump.*

PARTS CATALOG P/N: 37-084 (8-80)

Comments: The Series II Cougar, Panther and Turbo Tiger were the first tractors produced featuring the tilt-up hood.

Serial No. Range By Model/Year

Model	Year	Beginning S/N
ST 300	1974	20501
ST 300	1975	20726
ST 300	1976	21220

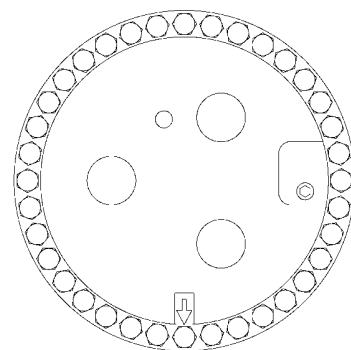

HD CLARK WHEEL END

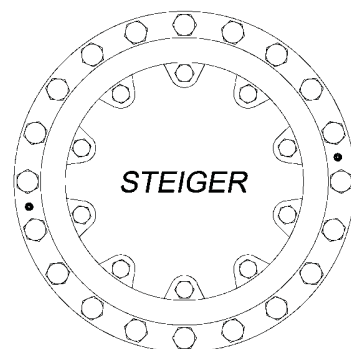

RABA K598 00/10 WHEEL END

MA98F017

Series II Cougar ST 300

BELT P/Ns

Engine Fan:	06-076 (w/D333 Engine)
.....	06-1463 (w/3306 Engine)
Alternator:	(w/Fan))
A/C Compressor:	06-024 (w/D333 Engine)
.....	06-1428 (w/3306 Engine)

FILTER P/Ns

Engine Air (Primary):.....	28-020S1 (std life)
.....	28-020 (ext. life)
Engine Air (Safety):	28-021
Cab Air:.....	64-084
Engine Oil:.....	28-024 (w/D333 Engine)
.....	28-036 (w/3306 Engine)
Engine Fuel:	28-025
Transmission/Transfer Case:	18-502
Hydraulic:	18-842

Series II Panther 1974 - 1976



MK98E019

MODEL ST 310

ENGINE: Cummins NT-855-C310 in-line 6 cyl

AXLE: Dana (Model A305) or STEIGER/Raba K598 00/10 outboard planetary

CLUTCH: Spicer-HD 15 inch dual plate

HYDRAULIC SYSTEM: Open center, 3-spool remote valve (std), 2-stage gear pump (steering and remotes)

TRANSFER CASE: Swinging type, oil cooled, tapered roller bearings with 1:1 Gear Ratio

TRANSMISSION: Spicer SST 1010 mechanical 10-speed, oil cooled.

Note: *The transmission and transfer case on this model share a central oil sump.*

PARTS CATALOG P/N: 37-084 (8-80)

Comments: The first Panther model tractor introduced and featured the 855 Cummins 6-cyl engine and the tilt-up hood.

Serial No. Range By Model/Year

Model	Year	Beginning S/N
ST 310	1974	90001
ST 310	1975	90037
ST 310	1976	90337

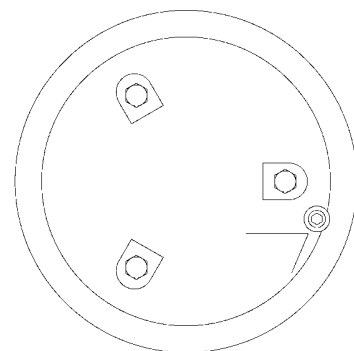

DANA WHEEL END

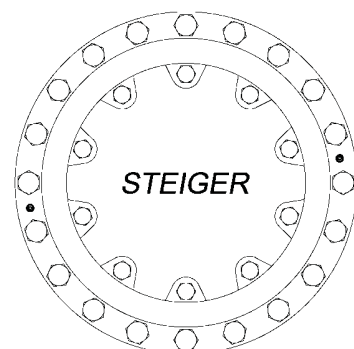

RABA K598 00/10 WHEEL END

MA98F018

Series II Panther ST 310 (Cummins 855)

BELT P/Ns

Engine Fan:	06-1547
Alternator:	06-1545
A/C Compressor:	06-1473
Water Pump:	06-1546

FILTER P/Ns

Engine Air (Primary):	28-029S1 (std life)
.....	28-029 (ext. life)
Engine Air (Safety):	28-030
Cab Air:	64-084
Engine Oil:	28-018 (cartridge, std)
.....	01-2187 (spin-on, if converted)
Luber Finer:	28-028 (cartridge, std)
.....	90-1158T1 (spin-on, if converted)
Engine Fuel:	28-035
Transmission/Transfer Case:	18-502
Hydraulic:	18-842
Water:	28-031

Series II Turbo Tiger 1974 - 1976



MK98E022

MODEL ST 320

ENGINE: Cummins VT903-V8

AXLE: Dana (Model A305) or STEIGER/Raba K598 00/10 outboard planetary

CLUTCH: Spicer-HD 14 inch dual plate

HYDRAULIC SYSTEM: Open center, 3-spool remote valve (std), 2-stage gear pump (steering and remotes)

TRANSFER CASE: Swinging type, oil cooled, tapered roller bearings with 1:1 Gear Ratio

TRANSMISSION: Spicer SST 1010 mechanical 10-speed, oil cooled.

Note: *The transmission and transfer case on this model share a central oil sump.*

PARTS CATALOG P/N: 37-084 (8-80)

Comments: The Series II Cougar, Panther and Turbo Tiger were the first tractors produced featuring the tilt-up hood.

Serial No. Range By Model/Year

Model	Year	Beginning S/N
ST 320	1974	30101
ST 320	1975	30198
ST 320	1976	30430

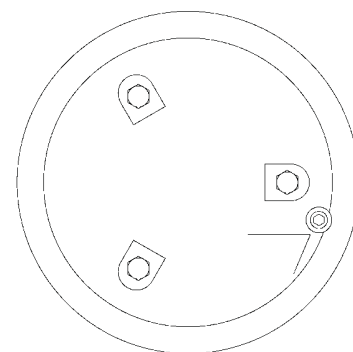

DANA WHEEL END

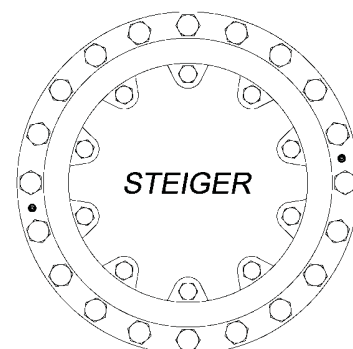

RABA K598 00/10 WHEEL END

MA98F018

Series II Turbo Tiger ST 320 (Cummins 903)

BELT P/Ns

Engine Fan:	06-096
Alternator:	06-097
A/C Compressor:	06-1453

FILTER P/Ns

Engine Air (Primary):.....	28-029S1 (std life)
.....	28-029 (ext. life)
Engine Air (Safety):	28-030
Cab Air:.....	64-084
Engine Oil:.....	28-018 (cartridge, std)
.....	01-2187 (spin-on, if converted)
Luber Finer:.....	28-028 (cartridge, std)
.....	90-1158T1 (spin-on, if converted)
Engine Fuel:.....	28-019
Transmission/Transfer Case:	18-502
Hydraulic:.....	18-842
Water:	28-031