

VOLVO EXCAVATORS

# EW180D, EW210D

18.2-20.3 t | 129 kW | 19.7-22.8 t | 129 kW





# A PASSION FOR PERFORMANCE.

At Volvo Construction Equipment, we're not just coming along for the ride. Developing products and services that raise productivity – we are confident we can lower costs and increase profits for industry experts. Part of the Volvo Group, we are passionate about innovative solutions to help you work smarter – not harder.

## Helping you to do more

Doing more with less is a trademark of Volvo Construction Equipment. High productivity has long been married to low energy consumption, ease of use and durability. When it comes to lowering life-cycle costs, Volvo is in a class of its own.

## Designed to fit your needs

There is a lot riding on creating solutions that are suited to the particular needs of different industry applications. Innovation often involves high technology – but it doesn't always have to. Some of our best ideas have been simple, based on a clear and deep understanding of our customers' working lives.



## You learn a lot in 175 years

Over the years, Volvo has advanced solutions that have revolutionized the use of construction equipment. No other name speaks Safety louder than Volvo. Protecting operators, those around them and minimizing our environmental impact are traditional values that continue to shape our product design philosophy.

## We're on your side

We back the Volvo brand with the best people. Volvo is truly a global enterprise, one that is on standby to support customers quickly and efficiently – wherever they are.

## We have a passion for performance.



Volvo Trucks

Renault Trucks

Mack Trucks





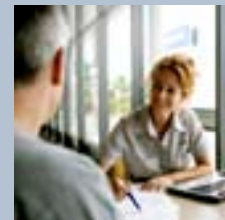

UD Trucks

Volvo Buses

Volvo Construction Equipment

Volvo Penta

Volvo Aero

Volvo Financial Services

# BUILT FOR EFFICIENCY.

At Volvo we are proud of our fuel efficient and environmentally responsible machines, we deliver more power for less fuel. The EW180D and EW210D are no exception; our newly developed engine meets all legislative requirements, improves performance and lowers fuel consumption to save you time and money.

## Fuel efficiency

Increased fuel efficiency from Volvo's D6 Stage IIIB/Tier 4 Interim engine, enhanced hydraulic system and well matched Volvo components. More power with ultimate efficiency.

## Diesel Particulate Filter (DPF)

The active-type DPF includes a Diesel Oxidation Catalyst function and regeneration burner. The system temporarily holds the exhaust fumes and incinerates them, lowering emissions without reducing performance.

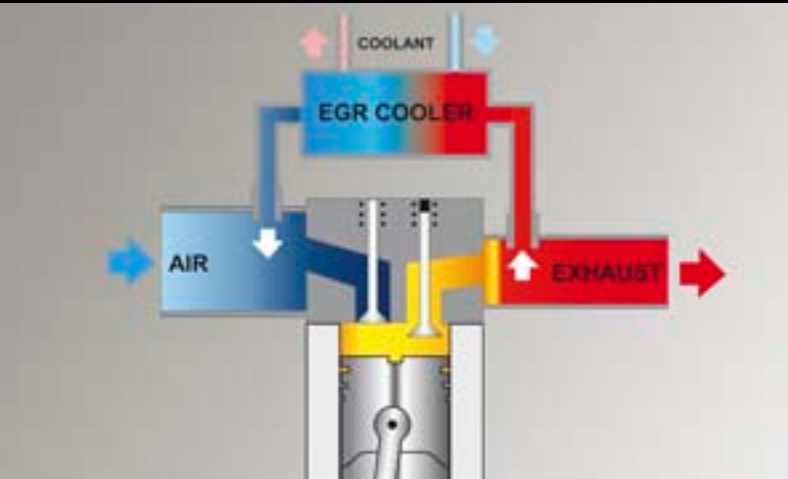

## Exhaust Gas Recirculation (EGR) and Electronic Control Unit (ECU)

Efficient cooled external EGR reduces oxygen concentration and decreases the combustion temperature for lower emissions. The ECU controls the mix of recirculated exhaust gas and fresh air – crucial for reducing emissions, performance and fuel economy.

## Regeneration

Particles collected during filter cleaning are oxidised and transformed into non-toxic CO<sub>2</sub> every 6-10 hours. Volvo's regeneration system does not interrupt operation, performance or productivity. Regeneration can be postponed if the timing is inconvenient.





**Volvo D6 Stage IIIB/Tier 4 Interim engine**

Volvo's efficient diesel engine with V-ACT technology gives you more power, while consuming less fuel, for high torque at low engine speeds. Low emission levels for ultimate efficiency and environmental care.



# DEMAND CONTROL.



## Industry-leading cab

All-round visibility and an excellent operator environment are at the heart of Volvo's cab design. The spacious cab, with ample storage and leg room and easy to access controls, increases operator productivity and reduces fatigue.

Volvo puts you in control with its industry leading cab; achieve more while working comfortably. Get productive with our excellent all-round visibility, increased safety and ample space. See more and do more with Volvo.

#### Adjustable steering column

Slim design of the easily adjustable steering column ensures visibility is not impaired for increased operator comfort.

#### ROPS

The cab features Roll Over Protective Structure (ROPS) which meets the ISO 12117-2 safety standard for increased peace of mind in the unlikely event of machine roll over.



#### Smart controls

Navigate through the colour I-ECU monitor via the conveniently located control panel. The monitor can be clearly read in all light conditions for easy visual and diagnostic checks, increasing uptime and productivity.

#### Automatic climate control system

Operators can set their ideal temperature with Volvo's powerful climate control system which is fitted as standard. Industry leading air circulation and defrosting capability is delivered with 14 well-spaced vents for increased comfort and productivity.



# WE SET THE STANDARD.

Quality is at the forefront of the wheeled excavator design. These tough machines are highly mobile, productive and flexible – both on and off-road. Trust Volvo for quality you can rely on.

## Anti-slip plate

Added operator and service mechanic safety from punched anti-slip plate which provides superb grip, especially in wet or icy conditions.



## Foot steps and hand rail

Safe and easy access to the machine is ensured by two convenient foot steps and a hand rail.



## LED rear lights

LED lights on the rear counterweight provide longer life time and improved appearance.



## Stays and locking devices

Volvo's automatic stays prevent doors being blown closed for added safety, they can easily be manually released. Automatic locks ensure the doors close properly and enhance appearance.

## Hammer/shear (X1) and attachment rotation (X3) management

Increase your wheeled excavator versatility with optional hydraulics functions X1 hammer/shear and X3 rotation. X1 function utilizes the main system hydraulic flow to operate attachments requiring one or two way flow whereas X3 function provides an appropriate 2 way flow for tilting or rotating attachments.

## Tightening eyes

A new type of over dimensioned tightening eyes secure the machine to the trailer and enable it to be lifted. The four eyes are on top of the undercarriage sides to ensure easy operator access.





#### Quality

Volvo matched components and an excellent combination of features come together to produce a quality machine. Our rear view camera is fitted as standard and provides superb clarity via the colour I-ECU monitor. An optional side view camera further increases safety.



# PERFORMANCE YOU CAN MEASURE.



## Increased digging power

Perform at a higher level with increased digging power for greater productivity. Optimized breakout and digging forces provided by perfectly dimensioned hydraulic cylinders and optimized equipment geometry.



The Volvo wheeled excavators are designed to help you do more. An enhanced hydraulic system and well matched Volvo components guarantee you increased digging performance. It all adds up to more with Volvo.

#### Attachment management system

Allows storage of up to 18 different attachment presets and enables hydraulic flow (standard) and pressure (optional) to be adjusted according to requirements. Operators can change attachments quickly without manual setup.

#### Eco mode

For increased fuel efficiency eco mode has been added to the choice of work modes available. Choose the correct mode according to your working conditions for added versatility and increased performance.

#### Travel motor

New electrical, proportional control travel motor provides increased controllability for smoother downhill rides and when increasing speed while carrying a heavy load. For all models except 20Km/h version.

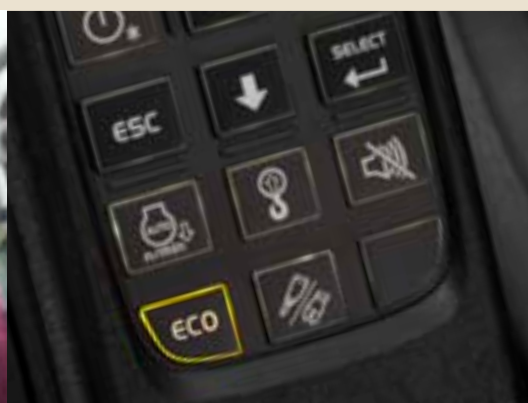

#### Tilt rotator

The optional tilt rotator acts as a wrist between the arm and bucket of the machine. It combines 360° rotary motion with 45° tilt action for flexibility and profitability.

#### Axle oscillation and lock

For increased off-road performance the front axle oscillation is 10° or 7° if mudguards are specified. Oscillation lock can be activated by the operator or automatically when 'Parking Mode' is selected.

#### Automatic idling system and automatic engine shut down

The idling system reduces rpm when the controls are inactive for a specified time (between 3-20 seconds). When the machine is stationary for the selected time the engine will automatically shut down – this is easily disabled and adjusted. Reduce fuel consumption and save money.



# EASY TO MAINTAIN.

Serviceability is built in to the new EW180D and EW210D. Easy access to grouped service points allows for fast and effortless maintenance and service checks. Increase your uptime with Volvo.

## Grouped filters

Grouped filters in the pump compartment are accessible via one door at ground level for faster servicing and more machine uptime.

## Fuel filler pump

Get more versatility from the fuel filler pump which allows for the machine to be re-filled from an external fuel tank. This provides 50l/min and an auto-stop function.

## Rear access

New rear entry behind the cab grants safe and easy access to the main hydraulic components and engine. Stairway allows for access to the top of the superstructure.



## CareTrack

Volvo's telematics system guides machine owners towards optimized productivity and their next service – remotely. Get fuel consumption and location reports to save fuel and reduce costs.

## Grouped greasing points

Conveniently located boom and arm greasing points are grouped for simplicity and ease of access. Greasing is needed at 50 hour intervals and at 250 hours for the slew ring. Quicker maintenance leads to increased productivity.

## Cooling system

Cooling fan speed is controlled to its need which reduces fuel consumption and noise. The three coolers – change air cooler, water cooler and hydraulic cooler – form a single layer layout and are cooled by one fan for a more compact design, which is easy to service and clean – guaranteeing you more uptime.





#### **Serviceability**

Grouped filters and accessible radiators are quick to access from ground level via large compartment doors – increasing safety. Fast and easy access for maintenance means regular checks are more likely to be done leading to longer machine operating life.



# THE COMPLETE PACKAGE.

## Boom configurations

The EW180D and EW210D are available with either a mono boom or a two piece boom providing increased flexibility and versatility.



## Performance

Perform at a higher level with increased digging force for greater productivity.

## Auto greasing system

This optional feature supplies the correct amount of lubrication to all greasing points on a timed basis for reduced costs.

## Higher working pressure

Reinforced digging equipment due to increased hydraulic pressure.

## Eco mode

Work in Volvo's new eco mode for increased fuel efficiency.







### Cab

Spacious cab with excellent all-round visibility and easy to access controls. Approved to ROPS safety standards.

### Diesel Particulate Filter (DPF)

The active-type DPF incinerates exhaust fumes to lower emissions.



### Stage IIIB/Tier 4 Interim engine

Volvo's efficient diesel engine with V-ACT technology gives you more power, while consuming less fuel for low emission levels.

### Heavy counterweight

An 18% heavier counterweight is available as an option on the EW210D for increased stability and versatility.



### Serviceability

Grouped filters are quick and easy to access from ground level via large compartment doors for increased safety.



### Quality

Volvo matched components and excellent features combine to produce a quality machine you can trust.

### Travel motor

New electrical, proportional control travel motor provides increased controllability for a smoother downhill ride.



# VOLVO EW180D IN DETAIL.

## Engine

The next-generation Volvo diesel engine uses Volvo Advanced Combustion Technology (V-ACT) to deliver lower emissions and maintain superior performance and fuel efficiency. The EU Stage IIIA compliant engine uses precise, high-pressure fuel injectors, turbo charger and air to air intercooler, and electronic engine controls to optimize machine performance.

Engine	VOLVO	D6H
Power output at	rpm	2 000
Gross (ISO 14396)	kW	129
	hp	175
Net (ISO 9249, DIN 6271)	kW	126
	hp	171
Max. torque at 1 500 rpm	Nm	758
No. of cylinders		6
Displacement	l	5.7
Bore	mm	98
Stroke	mm	126

## Electrical system

High-capacity electrical system that is well protected. Waterproof double-lock harness plugs are used to secure corrosion-free connections. The main relays and solenoid valves are shielded to prevent damage. The master switch is standard.

Voltage	V	24
Battery	V	2 x 12
Battery capacity	Ah	2 x 140
Alternator	V / A	28 / 120
Alternator rating	W	3 360

## Cab

New-design Volvo Care Cab with operator protective structure, large and roomy interior, more leg room and foot space. One way travel pedal with rocker switch control (F-N-R) on the right joystick. One-touch release for digging brake pedal. Audio system with remote control. 3 cup holders, 3 outlets, independently adjustable joystick consoles.

Excellent all-round visibility provided by maximized cab class, transparent roof hatch, 2-piece sliding door window and longstroke, easy to adjust and narrow steering column. The liftable front windshield can easily be stored in the inside roof space and clipped in position. The removable lower front glass can be stored in the side door pocket. Interior lighting consists of one reading light and one light with timer.

The pressurized and filtered cab air is supplied by a 14-vent climate-control providing fast defrosting and high cooling and heating performance.

Viscous / spring mounted suspension cushions protect the operator from vibrations. Deluxe air-suspension seat with adjustable seat suspension, height, tilt, recline and forward-backward settings. (option). Adjustable, easy to read 6.4" LCD color monitor provides real time information of machine functions and important diagnostic information and is switchable to rear view camera monitor

## Sound Level

In cab, acc. to ISO 6396	LpA dB(A)	70
External, acc. to ISO 6395	LwA dB(A)	103

(Directive 2000/14/EC)

## Undercarriage

Drive train: One big variable axial-piston motor on the two-step Power Shift gearbox gives power to front and rear axles, both with hub reductions.

Framework: All-welded robust torsion box frame.

Wheels: Alternative single and twin wheels available.

Front axle: Robust excavator axle with automatic or operator controlled front axle oscillation lock.

Oscillating	°	± 10
with mudguards	°	± 7
Twin wheels		10.00–20
Max. tractive force (net)	kN	104

## Travel speed

on road	km/h	20.0/30.0/35.0
off road	km/h	5.0/7.4/8.9
creep	km/h	3.7
Min. turning radius	m	7.6

## Brakes

Service brakes: servo-hydraulically manoeuvred self-adjusting wet multidiscs with two separate brake circuits.

Parking brake: negative wet disc in gear housing, spring applied and pressure released.

Digging brake: service brake with mechanical lock system.

Security system: The 2-circuit travel brakes are supplied with two accumulators in the event of failure in the service brake system.

## Total machine weights

Machine with 5.2 m mono boom, 2.45 m dipper arm, quickfit S1, 590 kg / 890 l bucket.

Dozer blade front and outriggers rear	kg	19 400
Dozer blade rear excl. outriggers	kg	18 200
Front and rear outriggers	kg	19 700

Machine with 5.3 m 2-piece boom, 2.45 m dipper arm, quickfit S1, 590 kg / 890 l bucket.

Dozer blade front and outriggers rear	kg	20 000
Dozer blade rear excl. outriggers	kg	18 800
Front and rear outriggers	kg	20 300

## Service refill capacities

Fuel tank	l	335
Hydraulic system, total	l	300
Hydraulic tank	l	165
Engine oil	l	25
Engine coolant	l	33
Transmission	l	2.5

## Axle differential:

Front axle	l	9.5
Rear axle	l	12.5
Final drive, wet disc type	l	4 x 2.5

## Hydraulic system

Closed-centre load sensing hydraulic system with pressure compensated valves. Load independence of movements. Flow sharing feature, combined with a high flow electronically controlled pump (power regulation). The system gives superior manoeuvrability and fast movements, for optimal working result and economy.

The following working modes are included in the system:

Parking mode (P): Parking position for optimal safety.

Travel mode (T): Engine speed is controlled by travel pedal stroke for low fuel consumption and noise.

Working mode (W): Full working flow with adjustable engine rpm for normal working and best speed utilisation.

Customer mode (C): Operator can set proper oil flow in accordance with job conditions.

Power Boost: All digging and lifting forces are increased.

## Hydraulic pumps:

### Max. flows:

<b>Main pump</b> (type low noise axial piston pump)	l/min	420
<b>Brake + steering pump</b> (type low noise gear pump)	l/min	36.1
<b>Servo pump</b> (type low noise gear pump)	l/min	15.2

### Max. pressure:

Implements	MPa	34/37.5
Travel system	MPa	37.5
Pilot System	MPa	3.5

## Slew system

The superstructure is slewed by the means of a radial piston motor without reduction gear.

Automatic slew holding brake and anti-rebound valve are standard.

Max slew speed	rpm	9.1
Max. slew torque	kNm	65.6



# VOLVO EW210D IN DETAIL.

## Engine

The next-generation Volvo diesel engine uses Volvo Advanced Combustion Technology (V-ACT) to deliver lower emissions and maintain superior performance and fuel efficiency. The EU Stage IIIA compliant engine uses precise, high-pressure fuel injectors, turbo charger and air to air intercooler, and electronic engine controls to optimize machine performance.

Engine	VOLVO	D6H
Power output at	rpm	2 000
Gross (ISO 14396)	kW	129
	hp	173
Net (ISO 9249, DIN 6271)	kW	126
	hp	169
Max. torque at 1 500 rpm	Nm	758
No. of cylinders		6
Displacement	l	5.7
Bore	mm	98
Stroke	mm	126

## Electrical system

High-capacity electrical system that is well protected. Waterproof double-lock harness plugs are used to secure corrosion-free connections. The main relays and solenoid valves are shielded to prevent damage. The master switch is standard.

Voltage	V	24
Battery	V	2 x 12
Battery capacity	Ah	2 x 140
Alternator	V / A	28 / 120
Alternator rating	W	3 360

## Cab

New-design Volvo Care Cab with operator protective structure, large and roomy interior, more leg room and foot space. One way travel pedal with rocker switch control (F-N-R) on the right joystick. One-touch release for digging brake pedal. Audio system with remote control. 3 cup holders, 3 outlets, independently adjustable joystick consoles.

Excellent all-round visibility provided by maximized cab class, transparent roof hatch, 2-piece sliding door window and longstroke, easy to adjust and narrow steering column. The liftable front windshield can easily be stored in the inside roof space and clipped in position. The removable lower front glass can be stored in the side door pocket. Interior lighting consists of one reading light and one light with timer.

The pressurized and filtered cab air is supplied by a 14-vent climate-control providing fast defrosting and high cooling and heating performance.

Viscous/spring mounted suspension cushions protect the operator from vibrations. Deluxe air-suspension seat with adjustable seat suspension, height, tilt, recline and forward-backward settings. (option). Adjustable, easy to read 6.4" LCD color monitor provides real time information of machine functions and important diagnostic information and is switchable to rear view camera monitor

## Sound Level

In cab, acc. to ISO 6396	LpA dB(A)	70
External, acc. to ISO 6395	LwA dB(A)	103

(Directive 2000/14/EC)

## Undercarriage

Drive train: One big variable axial-piston motor on the two-step Power Shift gearbox gives power to front and rear axles, both with hub reductions.

Framework: All-welded robust torsion box frame.

Wheels: Alternative single and twin wheels available.

Front axle: Robust excavator axle with automatic or operator controlled front axle oscillation lock.

Oscillating	°	± 9
with mudguards	°	± 7
Twin wheels		10.00–20
Max. tractive force (net)	kN	121

## Travel speed

on road	km/h	20.0/25.0/30.0
off road	km/h	5.0/6.4/7.4
creep	km/h	3.2
Min. turning radius	m	8.1

## Brakes

Service brakes: servo-hydraulically manoeuvred self-adjusting wet multidiscs with two separate brake circuits.

Parking brake: negative wet disc in gear housing, spring applied and pressure released.

Digging brake: service brake with mechanical lock system.

Security system: The 2-circuit travel brakes are supplied with two accumulators in the event of failure in the service brake system.

## Total machine weights (\*heavy CWT / \*\*Standard CWT)

Machine with 5.6 m mono boom, 2.45 m dipper arm, quickfit S1, 810 kg / 1 350 l bucket.

Dozer blade front and outriggers rear	kg	21 700* / 20 900**
Dozer blade rear excl. outriggers	kg	20 400* / 19 700**
Front and rear outriggers	kg	22 100* / 21 300**

Machine with 5.5 m 2-piece boom, 2.45 m dipper arm, quickfit S1, 810 kg / 1 350 l bucket.

Dozer blade front and outriggers rear	kg	22 400* / 21 600**
Dozer blade rear excl. outriggers	kg	21 100* / 20 400**
Front and rear outriggers	kg	22 800* / 22 000**

## Service refill capacities

Fuel tank	l	335
Hydraulic system, total	l	330
Hydraulic tank	l	165
Engine oil	l	25
Engine coolant	l	33
Transmission	l	2.5

## Axle differential:

Front axle	l	9.5
Rear axle	l	14.5
Final drive, wet disc type	l	4 x 2.5

## Hydraulic system

Closed-centre load sensing hydraulic system with pressure compensated valves. Load independence of movements. Flow sharing feature, combined with a high flow electronically controlled pump (power regulation). The system gives superior manoeuvrability and fast movements, for optimal working result and economy.

The following working modes are included in the system:

Parking mode (P): Parking position for optimal safety.

Travel mode (T): Engine speed is controlled by travel pedal stroke for low fuel consumption and noise.

Working mode (W): Full working flow with adjustable engine rpm for normal working and best speed utilisation.

Customer mode (C): Operator can set proper oil flow in accordance with job conditions.

Power Boost: All digging and lifting forces are increased.

## Hydraulic pumps:

Max. flows:		
Main pump	l/min	420
(type low noise axial piston pump)		
Brake + steering pump	l/min	36.1
(type low noise gear pump)		
Servo pump	l/min	15.2
(type low noise gear pump)		
Max. pressure:		
Implements	MPa	34/37.5
Travel system	MPa	37.5
Pilot System	MPa	3.5

## Slew system

The superstructure is slewed by the means of a radial piston motor without reduction gear.

Automatic slew holding brake and anti-rebound valve are standard.

Max slew speed	rpm	9.7
Max. slew torque	kNm	77.5



# VOLVO EW180D DIMENSIONS.

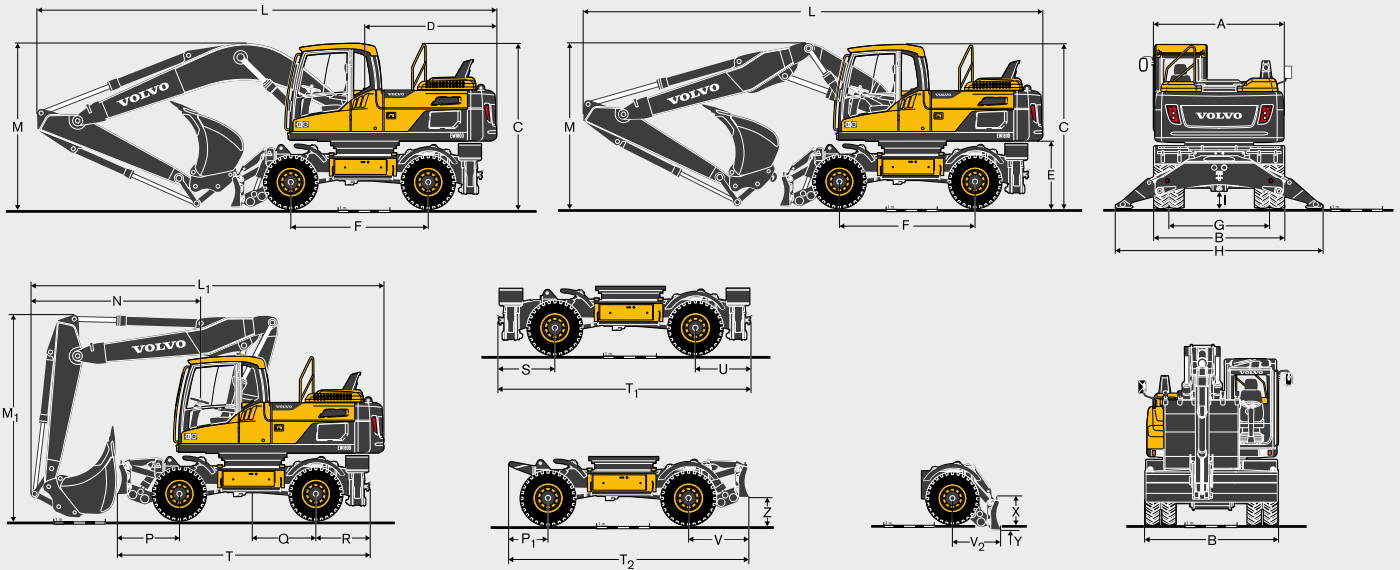

Description	Unit	Mono boom		2-piece boom	
		5.2		5.3	
A Overall width of superstructure	mm			2 520	2 520
B Overall width	mm			2 540 / 2 750	2 540 / 2 750
C Overall height of cab	mm			3 190	3 190
D Tail slew radius	mm			2 550	2 550
E Counterweight clearance	mm			1 280	1 280
F Wheel base	mm			2 650	2 650
G Tread	mm			1 940	1 940
H Outrigger width (front or rear)	mm			4 000	4 000
I Min. ground clearance	mm			333	333

Description	Unit	Mono boom				2-piece boom			
		5.2				5.3			
		Arm		Grab Arm		Arm		Grab Arm	
	m	2.45	2.6	3.0	3.2*	2.45	2.6	3.0	3.2*
L Overall length	mm	8 880	8 870	8 900	8 830	8 990	8 990	9 020	8 860*
M Overall height of boom	mm	3 220	3 180	3 480	3 580	3 220	3 200	3 340	3 530*
L <sub>1</sub> Overall length	mm					6 870	6 630**	6 670**	6 720*
M <sub>1</sub> Overall height of boom	mm					3 970	3 940**	3 940**	3 950*
N Front overhang	mm					3 280	3 040**	3 080**	3 130*

\*grab arm, without clamshell bucket | \*\* without bucket

Description	Unit	Undercarriage dimensions
P	mm	1 210
P <sub>1</sub>	mm	780
Q	mm	1 220
R/U	mm	1 040
S	mm	1 130
T	mm	4 900
T <sub>1</sub>	mm	4 820
T <sub>2</sub>	mm	4 560
V	mm	1 130
V <sub>2</sub>	mm	960
X	mm	630
Y	mm	155
Z	mm	470



# VOLVO EW210D DIMENSIONS.

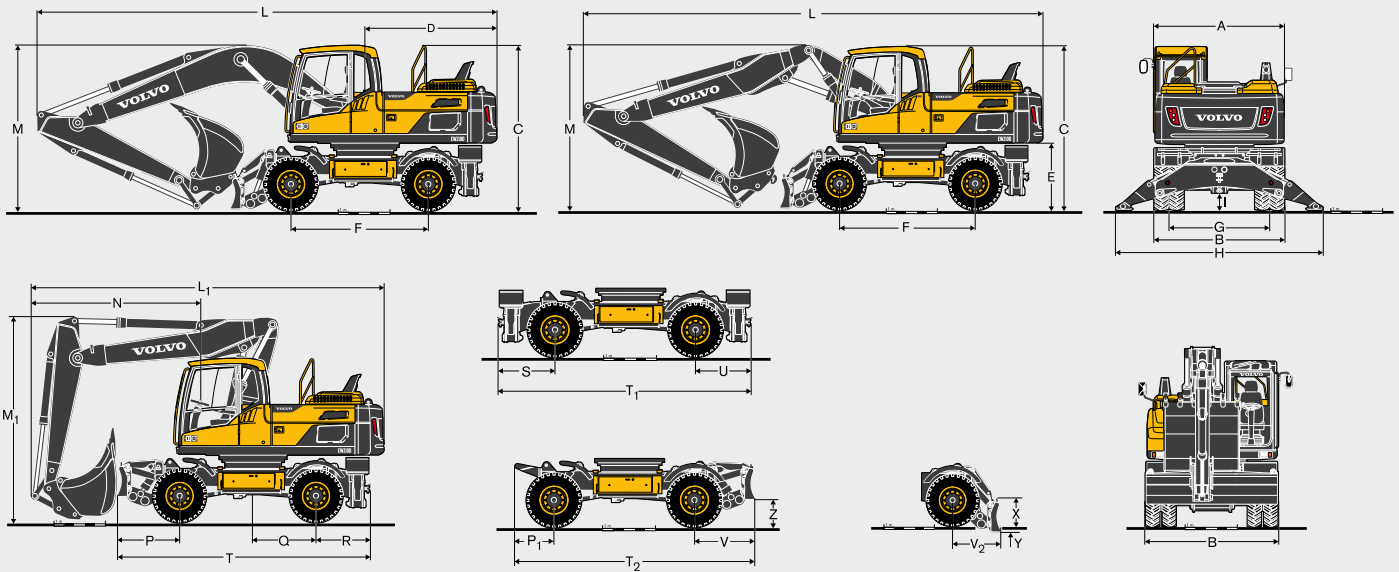

Description	Unit	Mono boom		2-piece boom	
		5.6		5.5	
A Overall width of superstructure	mm		2 520		2 520
B Overall width	mm		2 540 / 2 750		2 540 / 2 750
C Overall height of cab	mm		3 190		3 190
D Tail slew radius	mm		2 650		2 650
E Counterweight clearance	mm		1 280		1 280
F Wheel base	mm		2 750		2 750
G Tread	mm		1 940		1 940
H Outrigger width (front or rear)	mm		4 000		4 000
I Min. ground clearance	mm		350		350

Description	Unit	Mono boom				2-piece boom			
		5.6				5.5			
		Arm		Grab Arm		Arm		Grab Arm	
	m	2.45	2.6	2.9	3.2*	2.45	2.6	2.9	3.2*
L Overall length	mm	9 380	9 380	9 380	9 340*	9 300	9 320	9 330	9 150*
M Overall height of boom	mm	3 220	3 220	3 170	3 680*	3 080	3 080	3 080	3 490*
L <sub>1</sub> Overall length	mm					6 940	6 720**	6 740**	6 900*
M <sub>1</sub> Overall height of boom	mm					3 940	3 940**	3 940**	3 970*
N Front overhang	mm					3 250	3 030**	3 050**	3 210*

\*grab arm, without clamshell bucket | \*\* without bucket

Description	Unit	Undercarriage dimensions
P	mm	1 290
P <sub>1</sub>	mm	830
Q	mm	1 375
R/U	mm	1 070
S	mm	1 160
T	mm	5 110
T <sub>1</sub>	mm	4 980
T <sub>2</sub>	mm	4 780
V	mm	1 200
V <sub>2</sub>	mm	980
X	mm	630
Y	mm	132
Z	mm	450



# VOLVO EW180D WORKING RANGES AND DIGGING FORCES.

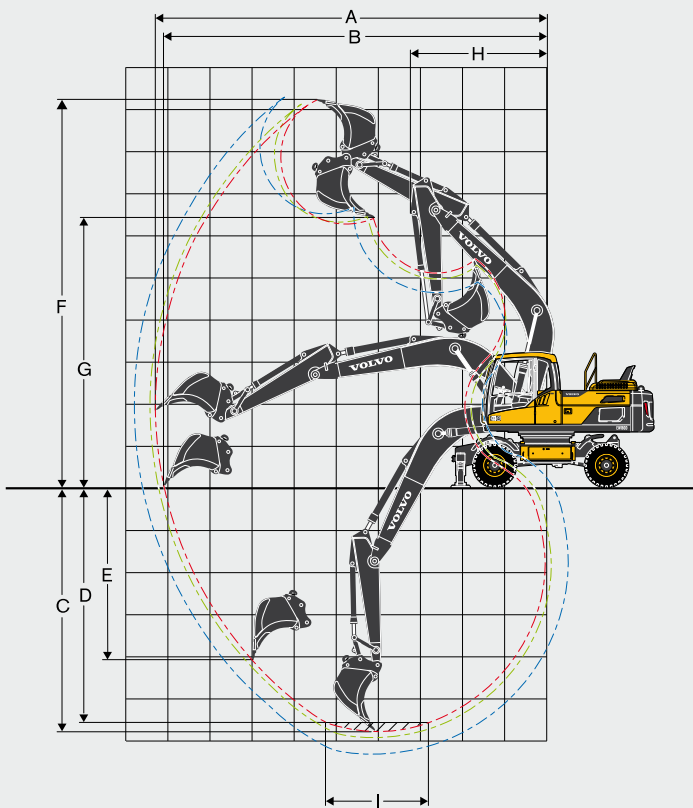

**Mono boom 5.2 m and dipper arm 2.45 m, 2.6 m, 3.0 m**

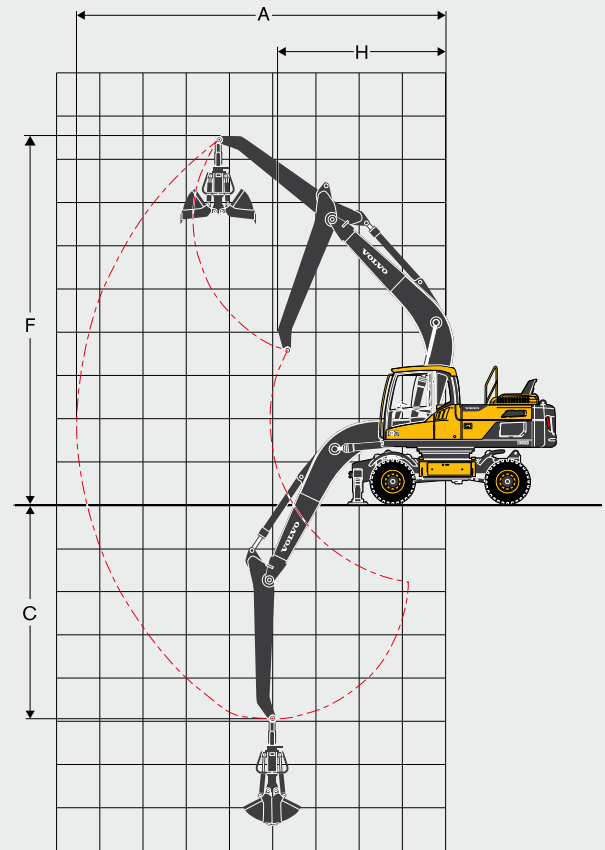

**Mono boom 5.2 m and grab arm 3.2 m**

Description	Unit	Mono boom				
		5.2				
		2.45	2.6	3.0	Grab arm 3.2	
A	Max. digging reach	mm	9 260	9 390	9 760	8 490
B	Max. digging reach on ground	mm	9 070	9 190	9 570	-
C	Max. digging depth	mm	5 790	5 940	6 340	4 980
D	Max. digging depth (l = 2 440 mm level)	mm	5 580	5 740	6 160	-
E	Max. vertical wall digging depth	mm	4 100	4 220	4 580	-
F	Max. cutting height	mm	9 150	9 190	9 380	9 370
G	Max. dumping height	mm	6 350	6 390	6 590	-
H	Min. front slew radius	mm	3 220	3 200	3 190	3 870
<b>Digging forces with direct fit bucket</b>						
Breakout force - bucket	(ISO)	kN	136	136	136	-
Tearout force	(ISO)	kN	106	102	92	-
<b>Max. recommended sizes for direct fit buckets</b>						
GP-Bucket (1.8 t/m <sup>3</sup> )		l	1 000	1 000	870	-
HD Bucket (2.1 t/m <sup>3</sup> )		l	700	700	700	-
<b>Max. recommended sizes for quick fit buckets</b>						
S1/S70 QF GP-Bucket (1.8 t/m <sup>3</sup> )		l	870	870	780	-
S1/S70 QF HD-Bucket (2.1 t/m <sup>3</sup> )		l	700	700	700	-
UQF GP-Bucket (1.8 t/m <sup>3</sup> )		l	870	870	780	-
UQF HD-Bucket (2.1 t/m <sup>3</sup> )		l	700	700	620	-

Note:

1. Bucket size based on SAE-J296, heaped material with a 1:1 angle of repose.
2. "Max permitted sizes" are for reference only and are not necessarily available from the factory.



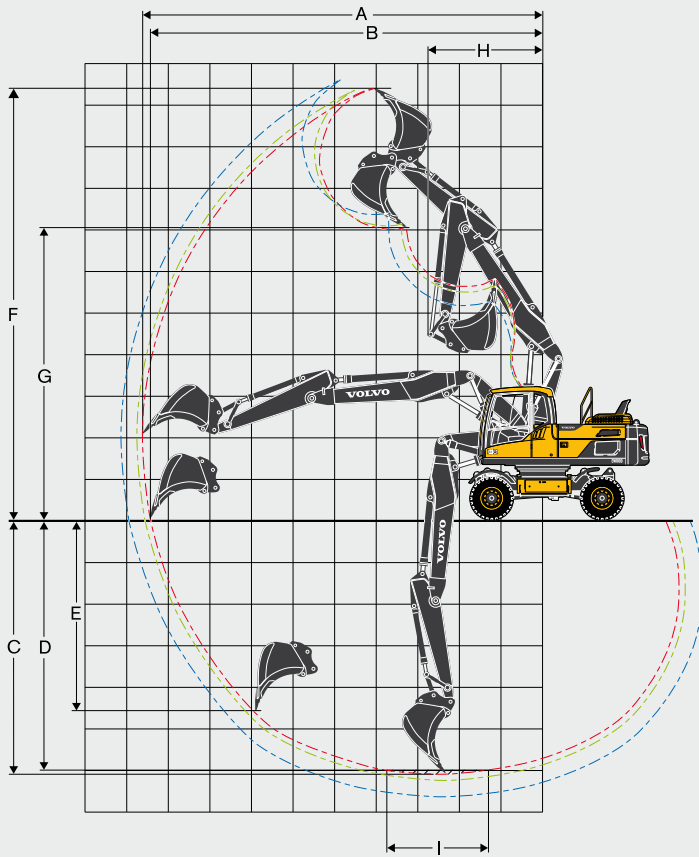

**2-piece boom 5.3 m and dipper arm 2.45 m, 2.6 m, 2.9 m**

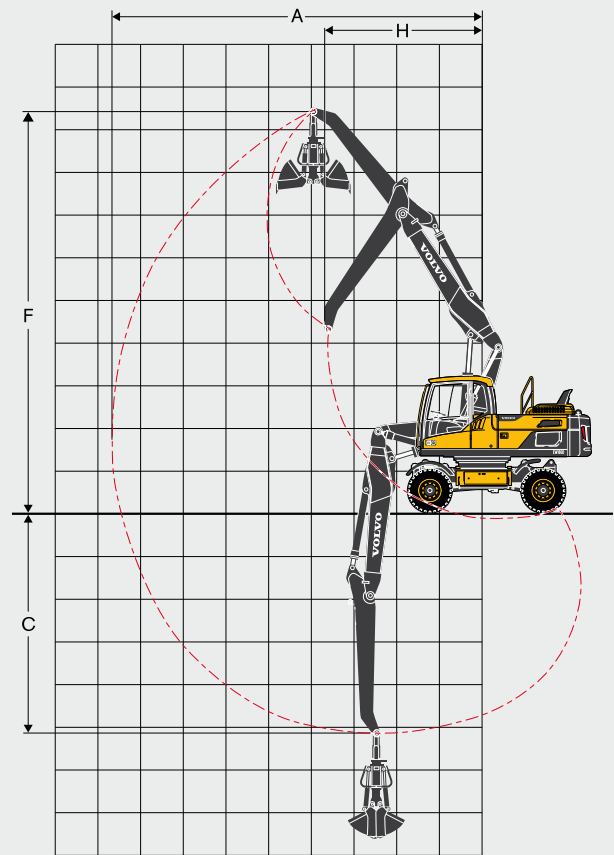

**2-piece boom 5.3 m and grab arm 3.2 m**

Description	Unit	2-piece boom			
		5.3			
		Arm		Grab arm	
	m	2.45	2.6	3.0	3.2
A Max. digging reach	mm	9 440	9 570	9 950	8 670
B Max. digging reach on ground	mm	9 250	9 380	9 770	-
C Max. digging depth	mm	5 980	6 130	6 530	5 190
D Max. digging depth (l = 2 440 mm level)	mm	5 890	6 030	6 440	-
E Max. vertical wall digging depth	mm	4 490	4 630	4 990	-
F Max. cutting height	mm	10 160	10 240	10 510	9 360
G Max. dumping height	mm	7 110	7 190	7 470	-
H Min. front slew radius	mm	2 750	2 750	2 830	3 700
<b>Digging forces with direct fit bucket</b>					
Breakout force - bucket (ISO)	kN	136	136	136	-
Tearout force (ISO)	kN	106	102	92	-
<b>Max. recommended sizes for direct fit buckets</b>					
GP-Bucket (1.8 t/m <sup>3</sup> )	l	1 000	870	870	-
HD Bucket (2.1 t/m <sup>3</sup> )	l	700	700	700	-
<b>Max. recommended sizes for quick fit buckets</b>					
S1/S70 QF GP-Bucket (1.8 t/m <sup>3</sup> )	l	870	780	700	-
S1/S70 QF HD-Bucket (2.1 t/m <sup>3</sup> )	l	700	700	620	-
UQF GP-Bucket (1.8 t/m <sup>3</sup> )	l	870	780	700	-
UQF HD-Bucket (2.1 t/m <sup>3</sup> )	l	700	700	620	-

Note:  
 1. Bucket size based on SAE-J296, heaped material with a 1:1 angle of repose.  
 2. "Max permitted sizes" are for reference only and are not necessarily available from the factory.

# VOLVO EW210D WORKING RANGES AND DIGGING FORCES.

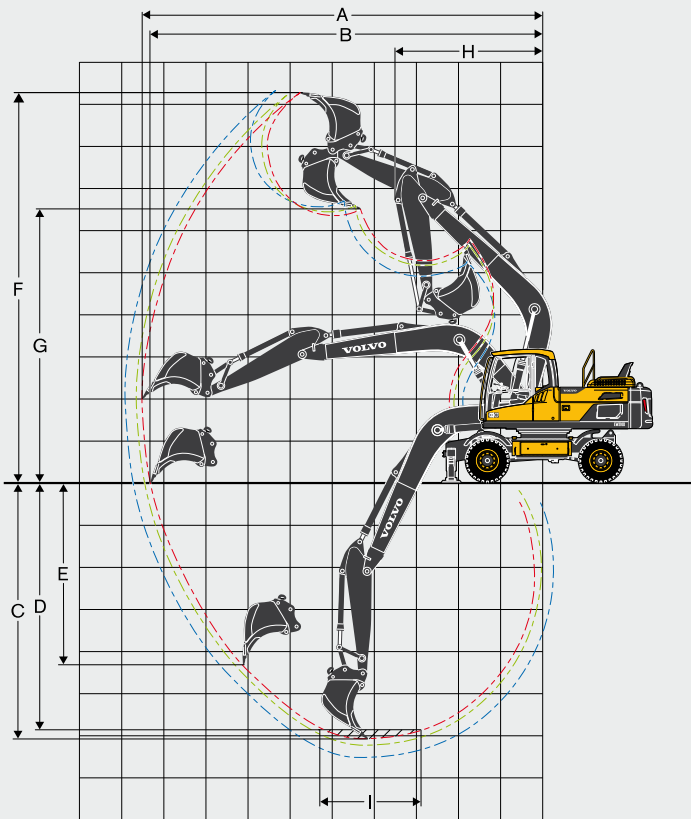

**Mono boom 5.6 m and dipper arm 2.45 m, 2.6 m, 2.9 m**

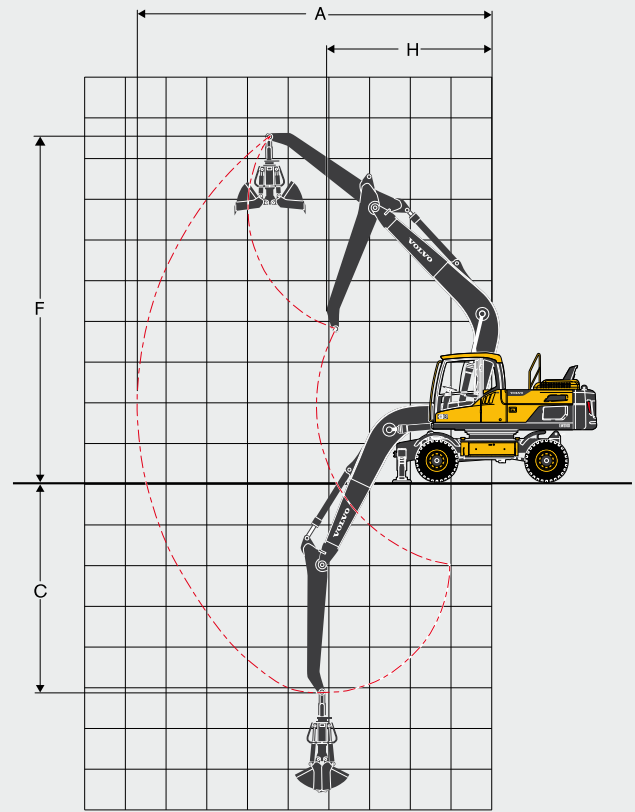

**Mono boom 5.6 m and grab arm 3.2 m**

Description	Unit	Mono boom			
		5.6			
		2.45	2.6	2.9	Grab arm 3.2*
A Max. digging reach	mm	9 640	9 770	10 050	8 890
B Max. digging reach on ground	mm	9 450	9 590	9 870	-
C Max. digging depth	mm	6 180	6 330	6 630	5 360
D Max. digging depth (l = 2 440 mm level)	mm	5 970	6 130	6 440	-
E Max. vertical wall digging depth	mm	4 390	4 530	4 810	-
F Max. cutting height	mm	9 370	9 440	9 590	8 620
G Max. dumping height	mm	6 570	6 640	6 780	-
H Min. front slew radius	mm	3 590	3 580	3 560	4 130
<b>Digging forces with direct fit bucket</b>					
Breakout force - bucket (ISO)	kN	149	149	149	-
Tearout force (ISO)	kN	123	118	109	-
<b>Max. recommended sizes for direct fit buckets</b>					
GP-Bucket (1.8 t/m <sup>3</sup> )	l	1 000	1 000	870	-
HD Bucket (2.1 t/m <sup>3</sup> )	l	780	780	780	-
<b>Max. recommended sizes for quick fit buckets</b>					
S1/S70 QF GP-Bucket (1.8 t/m <sup>3</sup> )	l	870	870	870	-
S1/S70 QF HD-Bucket (2.1 t/m <sup>3</sup> )	l	780	780	700	-
UQF GP-Bucket (1.8 t/m <sup>3</sup> )	l	870	870	780	-
UQF HD-Bucket (2.1 t/m <sup>3</sup> )	l	780	780	700	-

Note:  
 1. Bucket size based on SAE-J296, heaped material with a 1:1 angle of repose.  
 2. "Max permitted sizes" are for reference only and are not necessarily available from the factory.  
 3. Bucket recommendations with heavy counterweight.



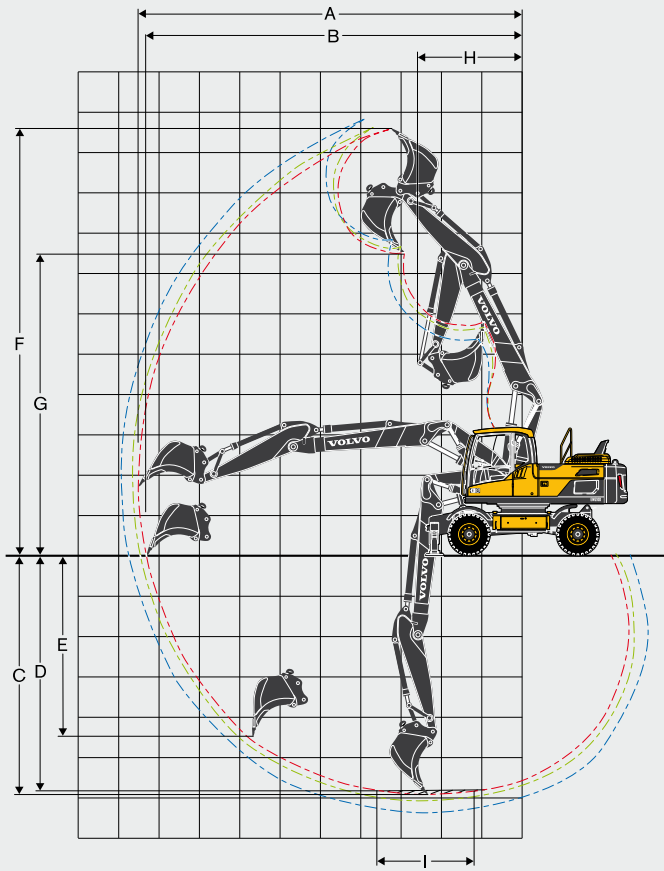

**2-piece boom 5.5 m and dipper arm 2.45 m, 2.6 m, 2.9 m**

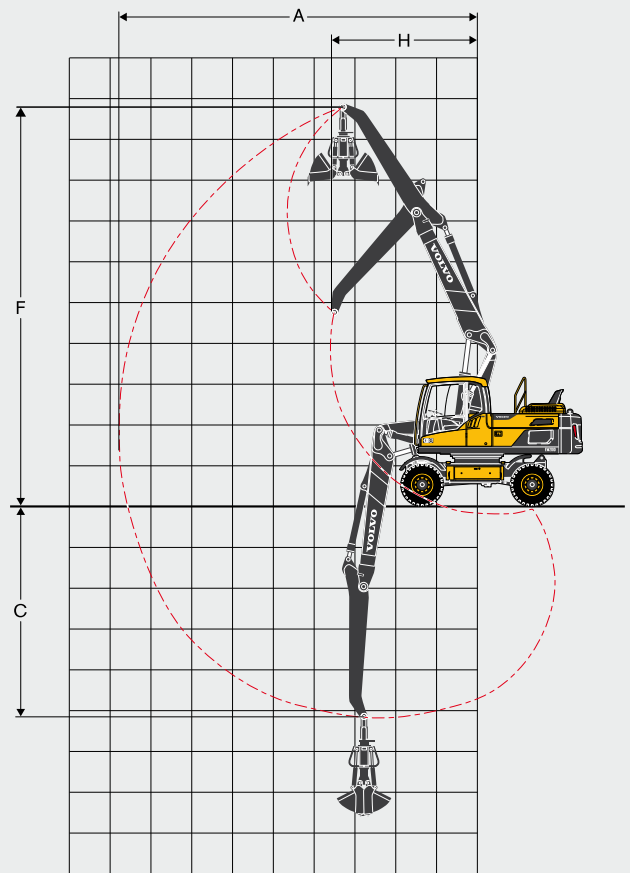

**2-piece boom 5.5 m and grab arm 3.2 m**



Description	Unit	2-piece boom			
		5.5			
		Arm	Grab arm		
	m	2.45	2.6	3.0	3.2
A Max. digging reach	mm	9 640	9 780	10 060	8 890
B Max. digging reach on ground	mm	9 450	9 590	9 880	-
C Max. digging depth	mm	6 050	6 200	6 500	5 240
D Max. digging depth (l = 2 440 mm level)	mm	5 920	6 100	6 400	-
E Max. vertical wall digging depth	mm	4 580	4 720	5 000	-
F Max. cutting height	mm	10 670	10 790	11 020	9 860
G Max. dumping height	mm	7 530	7 640	7 870	-
H Min. front slew radius	mm	2 630	2 680	2 770	3 630
<b>Digging forces with direct fit bucket</b>					
Breakout force - bucket (ISO)	kN	149	149	149	-
Tearout force (ISO)	kN	123	118	109	-
<b>Max. recommended sizes for direct fit buckets</b>					
GP-Bucket (1.8 t/m <sup>3</sup> )	l	1 000	1 000	870	-
HD Bucket (2.1 t/m <sup>3</sup> )	l	780	780	780	-
<b>Max. recommended sizes for quick fit buckets</b>					
S1/S70 QF GP-Bucket (1.8 t/m <sup>3</sup> )	l	870	870	780	-
S1/S70 QF HD-Bucket (2.1 t/m <sup>3</sup> )	l	780	780	700	-
UQF GP-Bucket (1.8 t/m <sup>3</sup> )	l	870	870	780	-
UQF HD-Bucket (2.1 t/m <sup>3</sup> )	l	780	780	700	-

Note:  
 1. Bucket size based on SAE-J296, heaped material with a 1:1 angle of repose.  
 2. "Max permitted sizes" are for reference only and are not necessarily available from the factory.  
 3. Bucket recommendations with heavy counterweight.





At the arm end, without bucket and quick fit. Unit: 1 000 kg. **With standard counterweight.**  
 For lifting capacity including bucket/quick fit, simply subtract actual weight of those parts from the following values.

 Across under-carriage  Along under-carriage	Arm end (bucket pivot) related to ground level	Reach from machine centre (u = support up/d = support down)																Max. m								
		1.5 m		3 m		4.5 m		6 m		7.5 m		Max.														
		u	d	u	d	u	d	u	d	u	d	u	d	u	d	u	d									
5.2 m mono boom 3.0 m dipper arm Outriggers front and rear	7.5 m	-	-	-	-	-	-	-	-	-	-	-	-	-	-	-	-	-	-	3.5*	3.5*	3.5*	3.5*	5.8		
	6 m	-	-	-	-	-	-	-	-	-	-	-	3.5	5.5*	5.1	5.5*	-	-	-	-	2.6	3.2*	3.2*	3.2*	7.0	
	4.5 m	-	-	-	-	-	-	-	-	-	-	-	3.4	6.0*	4.9	6.0*	2.3	4.4*	3.4	4.4*	2.2	3.2*	3.2*	3.2*	7.7	
	3 m	-	-	-	-	8.7	13.4*	13.4*	13.4*	4.8	8.6*	7.4	8.6*	3.2	6.8*	4.7	6.8*	2.2	4.9	3.3	6.0*	2.0	3.3*	2.9	3.3*	8.1
	1.5 m	-	-	-	-	6.6*	6.6*	6.6*	6.6*	4.4	10.5*	6.9	10.5*	3.0	6.7	4.5	7.7*	2.1	4.7	3.2	6.4*	1.9	3.5*	2.8	3.5*	8.2
	0 m	-	-	-	-	7.3	8.0*	8.0*	8.0*	4.1	10.4	6.6	11.5*	2.8	6.5	4.3	8.3*	2.1	4.7	3.2	6.6*	1.9	4.0*	2.9	4.0*	8.0
	-1.5 m	7.6*	7.6*	7.6*	7.6*	7.3	11.9*	11.9*	11.9*	4.0	10.2	6.5	11.5*	2.7	6.4	4.3	8.4*	-	-	-	-	2.1	4.7	3.2	4.8*	7.4
	-3 m	11.7*	11.7*	11.7*	11.7*	7.4	14.9*	13.2	14.9*	4.1	10.3	6.5	10.3*	2.8	6.4	4.3	7.4*	-	-	-	-	2.5	5.7	3.8	6.5*	6.5
-4.5 m	-	-	-	-	7.7	10.6*	10.6*	10.6*	4.3	7.4*	6.7	7.4*	-	-	-	-	-	-	-	-	3.8	6.4*	5.9	6.4*	5.0	
5.2 m mono boom 3.2 m dipper arm Outriggers front and rear	7.5 m	-	-	-	-	-	-	-	-	-	-	-	-	-	-	-	-	-	-	-	3.4	5.0*	4.9	5.0*	6.2	
	6 m	-	-	-	-	-	-	-	-	-	-	-	-	3.7	5.5*	5.3	5.5*	-	-	-	-	2.6	4.6*	3.8	4.6*	7.4
	4.5 m	-	-	-	-	-	-	-	-	-	-	-	-	3.6	6.0*	5.2	6.0*	2.5	5.2	3.6	5.7*	2.2	4.4*	3.2	4.4*	8.0
	3 m	-	-	-	-	-	-	-	-	5.1	8.5*	7.7	8.5*	3.4	6.9*	4.9	6.9*	2.4	5.1	3.5	6.1*	2.0	4.2	3.0	4.5*	8.4
	1.5 m	-	-	-	-	-	-	-	-	4.6	10.5*	7.1	10.5*	3.2	6.9	4.7	7.8*	2.3	4.9	3.4	6.5*	1.9	4.1	2.9	4.7*	8.5
	0 m	-	-	-	-	-	-	-	-	4.3	10.6	6.8	11.6*	3.0	6.7	4.5	8.5*	2.2	4.8	3.3	6.8*	2.0	4.2	2.9	5.2*	8.3
	-1.5 m	-	-	-	-	7.4	10.8*	10.8*	10.8*	4.2	10.4	6.7	11.7*	2.9	6.6	4.4	8.6*	2.2	4.8	3.3	6.6*	2.1	4.6	3.2	6.0*	7.8
	-3 m	10.8*	10.8*	10.8*	10.8*	7.5	15.6*	13.3	15.6*	4.2	10.4	6.7	10.7*	2.9	6.6	4.4	7.8*	-	-	-	-	2.5	5.4	3.7	6.3*	6.9
-4.5 m	-	-	-	-	7.8	11.6*	11.6*	11.6*	4.4	8.1*	6.9	8.1*	-	-	-	-	-	-	-	-	3.5	6.1*	5.3	6.1*	5.4	
5.2 m mono boom 2.45 m dipper arm Blade rear	7.5 m	-	-	-	-	-	-	-	-	-	-	-	-	-	-	-	-	-	-	-	4.2	4.6*	4.6*	4.6*	5.1	
	6 m	-	-	-	-	-	-	-	-	-	-	-	-	3.2	3.6	5.0	6.2*	-	-	-	-	2.8	3.2	4.1*	4.1*	6.4
	4.5 m	-	-	-	-	-	-	-	-	4.8	5.4	7.5*	7.5*	3.1	3.5	4.9	6.5*	-	-	-	-	2.3	2.6	3.6	4.0*	7.2
	3 m	-	-	-	-	-	-	-	-	4.4	5.0	7.2	9.4*	2.9	3.3	4.7	7.3*	2.1	2.3	3.3	5.2*	2.0	2.3	3.2	4.2*	7.6
	1.5 m	-	-	-	-	-	-	-	-	4.0	4.6	6.8	11.1*	2.8	3.1	4.5	8.1*	2.0	2.3	3.2	5.7	1.9	2.2	3.1	4.5*	7.7
	0 m	-	-	-	-	6.9	7.2*	7.2*	7.2*	3.9	4.4	6.6	11.7*	2.6	3.0	4.3	8.0	-	-	-	-	2.0	2.2	3.2	5.2*	7.5
	-1.5 m	-	-	-	-	6.9	8.1	13.1*	13.1*	3.8	4.4	6.5	11.3*	2.6	2.9	4.3	8.0	-	-	-	-	2.2	2.5	3.6	6.4	6.9
	-3 m	-	-	-	-	7.1	8.2	13.3	13.4*	3.9	4.4	6.6	9.6*	-	-	-	-	-	-	-	-	2.7	3.1	4.5	6.9*	5.9
5.2 m mono boom 2.6 m dipper arm Blade rear	7.5 m	-	-	-	-	-	-	-	-	-	-	-	-	-	-	-	-	-	-	-	4.0	4.2*	4.2*	4.2*	5.2	
	6 m	-	-	-	-	-	-	-	-	-	-	-	-	3.2	3.6	5.0	6.0*	-	-	-	-	2.7	3.0	3.8*	3.8*	6.6
	4.5 m	-	-	-	-	-	-	-	-	4.9	5.4	7.3*	7.3*	3.1	3.5	4.9	6.4*	-	-	-	-	2.2	2.5	3.5	3.8*	7.3
	3 m	-	-	-	-	-	-	-	-	4.5	5.0	7.3	9.2*	2.9	3.3	4.7	7.2*	2.1	2.3	3.3	5.7*	2.0	2.2	3.2	3.9*	7.7
	1.5 m	-	-	-	-	-	-	-	-	4.1	4.6	6.8	11.0*	2.8	3.1	4.5	8.0*	2.0	2.2	3.2	5.7	1.9	2.1	3.0	4.2*	7.8
	0 m	-	-	-	-	6.8	7.6*	7.6*	7.6*	3.8	4.4	6.6	11.7*	2.6	3.0	4.3	8.0	1.9	2.2	3.2	5.6	1.9	2.2	3.1	4.8*	7.6
	-1.5 m	8.4*	8.4*	8.4*	8.4*	6.9	8.0	12.8*	12.8*	3.8	4.3	6.5	11.3*	2.6	2.9	4.3	8.0	-	-	-	-	2.1	2.4	3.4	6.0*	7.0
	-3 m	-	-	-	-	7.0	8.2	13.3	13.8*	3.8	4.4	6.6	9.8*	2.6	3.0	4.3	6.9*	-	-	-	-	2.6	3.0	4.3	6.8*	6.0
5.2 m mono boom 3.0 m dipper arm Blade rear	7.5 m	-	-	-	-	-	-	-	-	-	-	-	-	-	-	-	-	-	-	-	3.4	3.5*	3.5*	3.5*	5.8	
	6 m	-	-	-	-	-	-	-	-	-	-	-	-	3.2	3.6	5.0	5.5*	-	-	-	-	2.5	2.7	3.2*	3.2*	7.0
	4.5 m	-	-	-	-	-	-	-	-	-	-	-	-	3.1	3.5	4.9	6.0*	2.1	2.4	3.4	4.4*	2.0	2.3	3.2*	3.2*	7.7
	3 m	-	-	-	-	8.2	9.4	13.4*	13.4*	4.5	5.1	7.4	8.6*	3.0	3.3	4.7	6.8*	2.1	2.3	3.3	5.8	1.8	2.0	2.9	3.3*	8.1
	1.5 m	-	-	-	-	6.6*	6.6*	6.6*	6.6*	4.1	4.7	6.9	10.5*	2.8	3.1	4.5	7.7*	2.0	2.2	3.2	5.7	1.7	1.9	2.8	3.5*	8.2
	0 m	-	-	-	-	6.8	7.9	8.0*	8.0*	3.8	4.4	6.6	11.5*	2.6	3.0	4.3	8.0	1.9	2.2	3.1	5.6	1.7	2.0	2.9	4.0*	8.0
	-1.5 m	7.6*	7.6*	7.6*	7.6*	6.8	7.9	11.9*	11.9*	3.7	4.3	6.4	11.5*	2.5	2.9	4.2	7.9	-	-	-	-	1.9	2.2	3.1	4.8*	7.4
	-3 m	11.7*	11.7*	11.7*	11.7*	6.9	8.0	13.1	14.9*	3.8	4.3	6.5	10.3*	2.5	2.9	4.3	7.4*	-	-	-	-	2.3	2.6	3.8	6.5*	6.5
-4.5 m	-	-	-	-	7.2	8.3	10.6*	10.6*	3.9	4.5	6.7	7.4*	-	-	-	-	-	-	-	-	3.5	3.9	5.8	6.4*	5.0	
5.2 m mono boom 3.2 m dipper arm for grab Blade rear	7.5 m	-	-	-	-	-	-	-	-	-	-	-	-	3.4	3.8	5.2	5.7*	-	-	-	-	3.2	3.6	4.9	5.0*	6.2
	6 m	-	-	-	-	-	-	-	-	-	-	-	-	3.5	3.8	5.3	5.5*	-	-	-	-	2.4	2.7	3.7	4.6*	7.4
	4.5 m	-	-	-	-	-	-	-	-	-	-	-	-	3.4	3.7	5.1	6.0*	2.3	2.6	3.6	5.7*	2.1	2.3	3.2	4.4*	8.0
	3 m	-	-	-	-	-	-	-	-	4.8	5.3	7.6	8.5*	3.2	3.5	4.9	6.9*	2.3	2.5	3.5	6.0	1.9	2.1	2.9	4.5*	8.4
	1.5 m	-	-	-	-	-	-	-	-	4.3	4.9	7.1	10.5*	2.9	3.3	4.7	7.8*	2.2	2.4	3.4	5.9	1.8	2.0	2.8	4.7*	8.5
	0 m	-	-	-	-	-	-	-	-	4.0	4.6	6.7	11.6*	2.8	3.1	4.5	8.2	2.1	2.3	3.3	5.8	1.8	2.0	2.9	5.0	8.3
	-1.5 m	-	-	-	-	6.9	8.0	10.8*	10.8*	3.9	4.4	6.6	11.7*	2.7	3.0	4.4	8.1	2.0	2.3	3.3	5.7	2.0	2.2	3.1	5.4	7.8
	-3 m	10.8*	10.8*	10.8*	10.8*	7.0	8.1	13.2	15.6*	3.9	4.5	6.6	10.7*	2.7	3.1	4.4	7.8*	-	-	-	-	2.3	2.6	3.7	6.3*	6.9
-4.5 m	-	-	-	-	7.3	8.4	11.6*	11.6*	4.1	4.6	6.8	8.1*	-	-	-	-	-	-	-	-	3.2	3.6	5.2	6.1*	5.4	



Notes:

- Working pressure with Power Boost = 37.5 MPa.
- The above values are in compliance with ISO standard 10 567. They do not exceed 87 % of hydraulic lifting capacity or 75 % of tipping load, with the machine on firm, level ground.
- Load capacities marked with an asterisk (\*) are limited by machine's hydraulic lifting capacity rather than tipping load.

# VOLVO EW180D LIFTING CAPACITY.

At the arm end, without bucket and quick fit. Unit: 1 000 kg. **With standard counterweight.**

For lifting capacity including bucket/quick fit, simply subtract actual weight of those parts from the following values.



 Across under-carriage  Along under-carriage	Arm end (bucket pivot) related to ground level	Reach from machine centre (u = support up/d = support down)																		Max. m								
		1.5 m		3 m		4.5 m		6 m		7.5 m		Max.																
		u	d	u	d	u	d	u	d	u	d	u	d	u	d	u	d	u	d									
5.3 m 2-piece boom	7.5 m	-	-	-	-	-	-	-	-	4.8*	4.8*	4.8*	4.8*	-	-	-	-	-	-	-	-	-	4.1	4.6*	4.6*	4.6*	5.3	
	6 m	-	-	-	-	-	-	-	-	4.9*	4.9*	4.9*	4.9*	3.4	5.1*	5.1*	5.1*	-	-	-	-	-	2.8	4.1*	4.1*	4.1*	6.6	
	4.5 m	-	-	-	-	7.8*	7.8*	7.8*	7.8*	5.1	6.2*	6.2*	6.2*	3.3	5.5*	5.0	5.5*	-	-	-	-	-	2.3	4.0*	3.5	4.0*	7.4	
	2.45 m dipper arm	3 m	-	-	-	-	-	-	-	-	4.7	8.2*	7.4	8.2*	3.1	5.5	4.8	6.4*	2.2	3.9	3.4	5.8*	2.0	3.6	3.2	4.1*	7.8	
	Front dozer blade	1.5 m	-	-	-	-	-	-	-	-	4.2	8.1	6.9	10.2*	2.9	5.3	4.6	7.4*	2.1	3.8	3.3	6.2*	1.9	3.5	3.1	4.3*	7.9	
	Rear outriggers	0 m	-	-	-	-	-	-	-	-	4.0	7.8	6.7	11.3*	2.7	5.1	4.4	8.1*	2.0	3.7	3.2	6.5*	2.0	3.6	3.1	4.8*	7.7	
5.3 m 2-piece boom 2.6 m dipper arm	-1.5 m	-	-	-	-	7.2	11.6*	11.6*	11.6*	4.0	7.8	6.6	11.4*	2.7	5.0	4.4	8.3*	-	-	-	-	-	2.2	4.0	3.5	5.9*	7.1	
	3 m	-	-	-	-	7.4	15.6*	13.5	15.6*	4.0	7.8	6.7	10.7*	2.8	5.1	4.4	7.6*	-	-	-	-	-	2.7	5.0	4.3	7.4*	6.1	
	7.5 m	-	-	-	-	-	-	-	-	-	4.5*	4.5*	4.5*	4.5*	-	-	-	-	-	-	-	-	-	3.9	4.2*	4.2*	4.2*	5.5
	6 m	-	-	-	-	-	-	-	-	-	4.6*	4.6*	4.6*	4.6*	3.4	4.9*	4.9*	4.9*	-	-	-	-	-	2.7	3.8*	3.8*	3.8*	6.8
	4.5 m	-	-	-	-	7.3*	7.3*	7.3*	7.3*	5.2	5.9*	5.9*	5.9*	3.3	5.4*	5.0	5.4*	2.3	4.0	3.5	4.0*	2.2	3.7*	3.4	3.7*	7.5		
	3 m	-	-	-	-	-	-	-	-	-	4.7	8.0*	7.5	8.0*	3.1	5.5	4.8	6.3*	2.2	3.9	3.4	5.6*	2.0	3.5	3.1	3.8*	7.9	
5.3 m 3.0 m dipper arm	1.5 m	-	-	-	-	-	-	-	-	4.3	8.1	7.0	10.0*	2.9	5.3	4.6	7.3*	2.1	3.8	3.3	6.1*	1.9	3.4	3.0	4.0*	8.0		
	Front dozer blade	0 m	-	-	-	6.1*	6.1*	6.1*	6.1*	4.0	7.8	6.7	11.2*	2.7	5.1	4.4	8.0*	2.0	3.7	3.2	6.5*	1.9	3.5	3.1	4.5*	7.8		
	Rear outriggers	-1.5 m	-	-	-	7.1	11.4*	11.4*	11.4*	3.9	7.7	6.6	11.4*	2.7	5.0	4.3	8.3*	-	-	-	-	-	2.1	3.9	3.4	5.5*	7.2	
	3 m	-	-	-	-	7.3	15.9*	13.5	15.9*	4.0	7.8	6.7	10.8*	2.7	5.1	4.4	7.8*	-	-	-	-	-	2.6	4.8	4.1	7.2*	6.3	
	7.5 m	-	-	-	-	-	-	-	-	-	-	-	-	-	3.4	3.9*	3.9*	3.9*	-	-	-	-	-	3.4	3.5*	3.5*	3.5*	6.1
	6 m	-	-	-	-	-	-	-	-	-	-	-	-	-	3.5	4.4*	4.4*	4.4*	-	-	-	-	-	2.5	3.2*	3.2*	3.2*	7.2
5.3 m 3.0 m dipper arm	4.5 m	-	-	-	-	-	-	-	-	5.2*	5.2*	5.2*	5.2*	3.4	4.9*	4.9*	4.9*	2.3	4.0	3.5	4.9*	2.0	3.1*	3.1*	3.1*	7.9		
	3 m	-	-	-	-	8.6	11.7*	11.7*	11.7*	4.8	7.3*	7.3*	7.3*	3.1	5.5	4.8	5.9*	2.2	3.9	3.4	5.3*	1.8	3.2*	2.9	3.2*	8.3		
	1.5 m	-	-	-	-	-	-	-	-	-	4.3	8.2	7.0	9.5*	2.9	5.3	4.6	7.0*	2.1	3.8	3.3	5.8*	1.7	3.2	2.8	3.4*	8.4	
	Front dozer blade	0 m	-	-	-	6.7*	6.7*	6.7*	6.7*	4.0	7.8	6.7	10.9*	2.7	5.1	4.4	7.8*	2.0	3.7	3.2	6.3*	1.8	3.2	2.8	3.8*	8.2		
	Rear outriggers	-1.5 m	-	-	-	7.0	10.7*	10.7*	10.7*	3.9	7.7	6.5	11.4*	2.6	5.0	4.3	8.2*	2.0	3.6	3.2	6.3	1.9	3.5	3.1	4.5*	7.7		
	3 m	-	-	-	-	7.2	16.5*	13.3	16.5*	3.9	11.0*	6.6	11.0*	2.6	8.0*	4.3	8.0*	-	-	-	-	-	2.3	4.2*	3.7	5.9*	6.8	
5.3 m 3.2 m Grab Arm	9 m	-	-	-	-	-	-	-	-	4.9*	4.9*	4.9*	4.9*	-	-	-	-	-	-	-	-	-	5.1*	5.1*	5.1*	5.1*	4.6	
	7.5 m	-	-	-	-	-	-	-	-	-	-	-	-	3.7	4.6*	4.6*	4.6*	-	-	-	-	-	3.2	4.9*	4.7	4.9*	6.5	
	6 m	-	-	-	-	-	-	-	-	-	-	-	-	3.7	4.4*	4.4*	4.4*	2.5	4.2	3.7	4.9*	2.5	4.2	3.7	4.6*	7.6		
	4.5 m	-	-	-	-	-	-	-	-	5.1*	5.1*	5.1*	5.1*	3.6	4.9*	4.9*	4.9*	2.5	4.2	3.7	4.9*	2.1	3.6	3.2	4.4*	8.2		
	3 m	-	-	-	-	-	-	-	-	5.0	7.2*	7.2*	7.2*	3.3	5.8	5.1	5.9*	2.4	4.1	3.6	5.4*	1.9	3.3	2.9	4.4*	8.6		
	1.5 m	-	-	-	-	-	-	-	-	4.5	8.4	7.2	9.4*	3.1	5.5	4.8	7.0*	2.3	4.0	3.5	5.9*	1.8	3.2	2.8	4.6*	8.7		
5.3 m 3.2 m Grab Arm	0 m	-	-	-	-	-	-	-	-	4.2	8.0	6.9	10.9*	2.9	5.3	4.6	7.9*	2.2	3.9	3.4	6.4*	1.8	3.3	2.9	5.0*	8.5		
	Rear outriggers	-1.5 m	-	-	-	7.1	9.4*	9.4*	9.4*	4.0	7.8	6.7	11.5*	2.8	5.1	4.5	8.4*	2.1	3.8	3.3	6.7*	2.0	3.5	3.1	5.7*	8.0		
	3 m	-	-	-	-	7.3	15.5*	13.4	15.5*	4.1	7.8	6.7	11.3*	2.8	5.1	4.5	8.3*	-	-	-	-	-	2.3	4.1	3.6	6.6*	7.1	
	4.5 m	-	-	-	-	-	-	-	-	4.2	8.0	6.9	9.8*	-	-	-	-	-	-	-	-	-	3.5	6.5	5.6	8.3*	5.2	
	7.5 m	-	-	-	-	-	-	-	-	4.8*	4.8*	4.8*	4.8*	-	-	-	-	-	-	-	-	-	4.1	4.6*	4.6*	4.6*	5.3	
	6 m	-	-	-	-	-	-	-	-	4.9*	4.9*	4.9*	4.9*	3.5	5.1*	5.1	5.1*	-	-	-	-	-	2.9	4.1*	4.1*	4.1*	6.6	
5.3 m 2-piece boom 2.45 m dipper arm	4.5 m	-	-	-	-	7.8*	7.8*	7.8*	7.8*	5.2	6.2*	6.2*	6.2*	3.3	5.5*	5.0	5.5*	-	-	-	-	-	2.3	4.0*	3.5	4.0*	7.4	
	3 m	-	-	-	-	-	-	-	-	4.7	8.2*	7.3	8.2*	3.1	6.4*	4.7	6.4*	2.2	4.9	3.4	5.8*	2.1	4.1*	3.1	4.1*	7.8		
	1.5 m	-	-	-	-	-	-	-	-	4.3	10.2*	6.9	10.2*	2.9	6.7	4.5	7.4*	2.1	4.8	3.3	6.2*	2.0	4.3*	3.0	4.3*	7.9		
	0 m	-	-	-	-	-	-	-	-	4.1	10.4	6.6	11.3*	2.8	6.6	4.4	8.1*	2.1	4.7	3.2	6.5*	2.0	4.6	3.1	4.8*	7.7		
	Rear outriggers	-1.5 m	-	-	-	7.3	11.6*	11.6*	11.6*	4.0	10.4	6.5	11.4*	2.7	6.5	4.3	8.3*	-	-	-	-	-	2.2	5.1	3.4	5.9*	7.1	
	3 m	-	-	-	-	7.5	15.6*	13.4	15.6*	4.1	10.5	6.6	10.7*	2.8	6.6	4.4	7.6*	-	-	-	-	-	2.8	6.4	4.3	7.4*	6.1	
5.3 m 2-piece boom 2.6 m dipper arm	7.5 m	-	-	-	-	-	-	-	-	4.5*	4.5*	4.5*	4.5*	-	-	-	-	-	-	-	-	-	3.9	4.2*	4.2*	4.2*	5.5	
	6 m	-	-	-	-	-	-	-	-	4.6*	4.6*	4.6*	4.6*	3.5	4.9*	4.9*	4.9*	-	-	-	-	-	2.8	3.8*	3.8*	3.8*	6.8	
	4.5 m	-	-	-	-	7.3*	7.3*	7.3*	7.3*	5.2	5.9*	5.9*	5.9*	3.4	5.4*	5.0	5.4*	2.3	4.0*	3.4	4.0*	2.3	3.7*	3.4	3.7*	7.5		
	3 m	-	-	-	-	-	-	-	-	4.8	8.0*	7.4	8.0*	3.2	6.3*	4.8	6.3*	2.2	4.9	3.4	5.6*	2.0	3.8*	3.1	3.8*	7.9		
	1.5 m	-	-	-	-	-	-	-	-	4.3	10.0*	6.9	10.0*	2.9	6.8	4.5	7.3*	2.1	4.8	3.3	6.1*	1.9	4.0*	2.9	4.0*	8.0		
	0 m	-	-	-	-	6.1*	6.1*	6.1*	6.1*	4.1	10.4	6.6	11.2*	2.8	6.6	4.4	8.0*	2.1	4.7	3.2	6.5*	1.9	4.5	3.0	4.5*	7.8		
5.3 m 2-piece boom 2.6 m dipper arm	Rear outriggers	-1.5 m	-	-	-	7.3	11.4*	11.4*	11.4*	4.0	10.3	6.5	11.4*	2.7	6.5	4.3	8.3*	-	-	-	-	-	2.1	4.9	3.3	5.5*	7.2	
	3 m	-	-	-	-	7.4	15.9*	13.3	15.9*	4.1	10.4	6.6	10.8*	2.8	6.5	4.3	7.8*	-	-	-	-	-	2.6	6.1	4.1	7.2*	6.3	

**Notes:**

- Working pressure with Power Boost = 37.5 MPa.
- The above values are in compliance with ISO standard 10 567. They do not exceed 87 % of hydraulic lifting capacity or 75 % of tipping load, with the machine on firm, level ground.
- Load capacities marked with an asterisk (\*) are limited by machine's hydraulic lifting capacity rather than tipping load.



At the arm end, without bucket and quick fit. Unit: 1 000 kg. **With standard counterweight.**  
 For lifting capacity including bucket/quick fit, simply subtract actual weight of those parts from the following values.

 Across under-carriage  Along under-carriage	Arm end (bucket pivot) related to ground level	Reach from machine centre (u = support up/d = support down)																		Max. m						
		1.5 m		3 m		4.5 m		6 m		7.5 m		Max.														
		u	d	u	d	u	d	u	d	u	d	u	d	u	d	u	d	u	d							
5.3 m 2-piece boom 3.0 m dipper arm Outriggers front and rear	7.5 m	-	-	-	-	-	-	-	-	-	-	-	3.5	3.9*	3.9*	3.9*	-	-	-	-	3.4	3.5*	3.5*	3.5*	6.1	
	6 m	-	-	-	-	-	-	-	-	-	-	-	3.5	4.4*	4.4*	4.4*	-	-	-	-	2.5	3.2*	3.2*	3.2*	7.2	
	4.5 m	-	-	-	-	-	-	-	5.2*	5.2*	5.2*	5.2*	3.4	4.9*	4.9*	4.9*	2.3	4.9*	3.5	4.9*	2.1	3.1*	3.1	3.1*	7.9	
	3 m	-	-	-	-	8.7	11.7*	11.7*	11.7*	4.9	7.3*	7.3*	7.3*	3.2	5.9*	4.8	5.9*	2.2	4.9	3.4	5.3*	1.9	3.2*	2.8	3.2*	8.3
	1.5 m	-	-	-	-	-	-	-	4.4	9.5*	6.9	9.5*	2.9	6.8	4.5	7.0*	2.1	4.8	3.3	5.8*	1.8	3.4*	2.7	3.4*	8.4	
	0 m	-	-	-	-	6.7*	6.7*	6.7*	6.7*	4.1	10.4	6.6	10.9*	2.8	6.6	4.3	7.8*	2.0	4.7	3.2	6.3*	1.8	3.8*	2.8	3.8*	8.2
	-1.5 m	-	-	-	-	7.1	10.7*	10.7*	10.7*	4.0	10.3	6.5	11.4*	2.7	6.4	4.2	8.2*	2.0	4.6	3.1	6.3	1.9	4.5*	3.0	4.5*	7.7
-3 m	-	-	-	-	7.3	16.5*	13.1	16.5*	4.0	11.0*	6.5	11.0*	2.7	8.0*	4.3	8.0*	-	-	-	-	2.3	5.4*	3.6	5.9*	6.8	
5.3 m 2-piece boom 3.2 m Grab Arm Outriggers front and rear	9 m	-	-	-	-	-	-	-	4.9*	4.9*	4.9*	4.9*	-	-	-	-	-	-	-	-	5.1*	5.1*	5.1*	5.1*	4.6	
	7.5 m	-	-	-	-	-	-	-	-	-	-	-	3.7	4.6*	4.6*	4.6*	-	-	-	-	-	3.2	4.9*	4.7	4.9*	6.5
	6 m	-	-	-	-	-	-	-	-	-	-	-	-	3.8	4.4*	4.4*	4.4*	2.5	4.9*	3.7	4.9*	2.5	4.6*	3.6	4.6*	7.6
	4.5 m	-	-	-	-	-	-	-	5.1*	5.1*	5.1*	5.1*	3.6	4.9*	4.9*	4.9*	2.5	4.9*	3.7	4.9*	2.1	4.4*	3.1	4.4*	8.2	
	3 m	-	-	-	-	-	-	-	5.1	7.2*	7.2*	7.2*	3.4	5.9*	5.0	5.9*	2.4	5.1	3.6	5.4*	1.9	4.1	2.9	4.4*	8.6	
	1.5 m	-	-	-	-	-	-	-	4.6	9.4*	7.2	9.4*	3.1	7.0	4.7	7.0*	2.3	5.0	3.4	5.9*	1.9	4.0	2.8	4.6*	8.7	
	0 m	-	-	-	-	-	-	-	4.2	10.6	6.8	10.9*	3.0	6.7	4.5	7.9*	2.2	4.9	3.3	6.4*	1.9	4.1	2.8	5.0*	8.5	
-1.5 m	-	-	-	-	7.3	9.4*	9.4*	9.4*	4.1	10.4	6.6	11.5*	2.8	6.6	4.4	8.4*	2.2	4.8	3.3	6.7*	2.0	4.4	3.0	5.7*	8.0	
-3 m	-	-	-	-	7.4	15.5*	13.2	15.5*	4.1	10.5	6.6	11.3*	2.8	6.6	4.4	8.3*	-	-	-	-	2.3	5.2	3.6	6.6*	7.1	
-4.5 m	-	-	-	-	-	-	-	-	4.3	9.8*	6.8	9.8*	-	-	-	-	-	-	-	-	3.6	8.3*	5.6	8.3*	5.2	
5.3 m 2-piece boom 2.45 m dipper arm Blade rear	7.5 m	-	-	-	-	-	-	-	4.8*	4.8*	4.8*	4.8*	-	-	-	-	-	-	-	-	3.9	4.3	4.6*	4.6*	5.3	
	6 m	-	-	-	-	-	-	-	4.9*	4.9*	4.9*	4.9*	3.2	3.6	5.1	5.1*	-	-	-	-	2.7	3.0	4.1*	4.1*	6.6	
	4.5 m	-	-	-	-	7.8*	7.8*	7.8*	7.8*	4.9	5.5	6.2*	6.2*	3.1	3.5	4.9	5.5*	-	-	-	-	2.2	2.4	3.5	4.0*	7.4
	3 m	-	-	-	-	-	-	-	4.4	5.0	7.3	8.2*	2.9	3.3	4.7	6.4*	2.1	2.3	3.3	5.8*	1.9	2.2	3.1	4.1*	7.8	
	1.5 m	-	-	-	-	-	-	-	4.0	4.6	6.8	10.2*	2.7	3.1	4.5	7.4*	2.0	2.2	3.2	5.8	1.8	2.1	3.0	4.3*	7.9	
	0 m	-	-	-	-	-	-	-	3.8	4.3	6.5	11.3*	2.6	2.9	4.3	8.1*	1.9	2.2	3.2	5.7	1.8	2.1	3.1	4.8*	7.7	
	-1.5 m	-	-	-	-	6.8	7.9	11.6*	11.6*	3.7	4.3	6.5	11.4*	2.5	2.9	4.3	8.1	-	-	-	-	2.0	2.3	3.4	5.9*	7.1
-3 m	-	-	-	-	6.9	8.1	13.3	15.6*	3.8	4.3	6.6	10.7*	2.6	3.0	4.3	7.6*	-	-	-	-	2.5	2.9	4.2	7.4*	6.1	
5.3 m 2-piece boom 2.6 m dipper arm Blade rear	7.5 m	-	-	-	-	-	-	-	4.5*	4.5*	4.5*	4.5*	-	-	-	-	-	-	-	-	3.7	4.1	4.2*	4.2*	5.5	
	6 m	-	-	-	-	-	-	-	4.6*	4.6*	4.6*	4.6*	3.3	3.6	4.9*	4.9*	-	-	-	-	2.6	2.9	3.8*	3.8*	6.8	
	4.5 m	-	-	-	-	7.3*	7.3*	7.3*	7.3*	4.9	5.5	5.9*	5.9*	3.1	3.5	4.9	5.4*	2.1	2.4	3.4	4.0*	2.1	2.4	3.4	3.7*	7.5
	3 m	-	-	-	-	-	-	-	4.4	5.0	7.3	8.0*	2.9	3.3	4.7	6.3*	2.1	2.3	3.3	5.6*	1.9	2.1	3.0	3.8*	7.9	
	1.5 m	-	-	-	-	-	-	-	4.0	4.6	6.8	10.0*	2.7	3.1	4.5	7.3*	2.0	2.2	3.2	5.8	1.8	2.0	2.9	4.0*	8.0	
	0 m	-	-	-	-	6.1*	6.1*	6.1*	6.1*	3.8	4.3	6.5	11.2*	2.6	2.9	4.3	8.0*	1.9	2.1	3.2	5.7	1.8	2.0	3.0	4.5*	7.8
	-1.5 m	-	-	-	-	6.7	7.9	11.4*	11.4*	3.7	4.2	6.5	11.4*	2.5	2.9	4.2	8.1	-	-	-	-	2.0	2.2	3.3	5.5*	7.2
-3 m	-	-	-	-	6.9	8.0	13.2	15.9*	3.7	4.3	6.5	10.8*	2.6	2.9	4.3	7.8*	-	-	-	-	2.4	2.8	4.1	7.2*	6.3	
5.3 m 2-piece boom 3.0 m dipper arm Blade rear	7.5 m	-	-	-	-	-	-	-	-	-	-	-	3.3	3.6	3.9*	3.9*	-	-	-	-	3.2	3.5*	3.5*	3.5*	6.1	
	6 m	-	-	-	-	-	-	-	-	-	-	-	3.3	3.7	4.4*	4.4*	-	-	-	-	2.3	2.6	3.2*	3.2*	7.2	
	4.5 m	-	-	-	-	-	-	-	5.0	5.2*	5.2*	5.2*	3.2	3.6	4.9*	4.9*	2.2	2.4	3.4	4.9*	1.9	2.2	3.1	3.1*	7.9	
	3 m	-	-	-	-	8.1	9.4	11.7*	11.7*	4.5	5.1	7.3*	7.3*	3.0	3.3	4.8	5.9*	2.1	2.3	3.3	5.3*	1.7	1.9	2.8	3.2*	8.3
	1.5 m	-	-	-	-	-	-	-	4.1	4.6	6.9	9.5*	2.7	3.1	4.5	7.0*	1.9	2.2	3.2	5.8	1.6	1.9	2.7	3.4*	8.4	
	0 m	-	-	-	-	6.6	6.7*	6.7*	6.7*	3.7	4.3	6.5	10.9*	2.5	2.9	4.3	7.8*	1.9	2.1	3.1	5.7	1.6	1.9	2.8	3.8*	8.2
	-1.5 m	-	-	-	-	6.6	7.7	10.7*	10.7*	3.6	4.2	6.4	11.4*	2.5	2.8	4.2	8.0	1.8	2.1	3.1	5.6	1.8	2.0	3.0	4.5*	7.7
-3 m	-	-	-	-	6.7	16.5*	13.0	16.5*	3.7	11.0*	6.4	11.0*	2.5	8.0*	4.2	8.0*	-	-	-	-	2.1	2.4*	3.6	5.9*	6.8	
5.3 m 2-piece boom 3.2 m Grab Arm Blade rear	9 m	-	-	-	-	-	-	-	4.9*	4.9*	4.9*	4.9*	-	-	-	-	-	-	-	-	5.1*	5.1*	5.1*	5.1*	4.6	
	7.5 m	-	-	-	-	-	-	-	-	-	-	-	3.5	3.9	4.6*	4.6*	-	-	-	-	3.0	3.4	4.7	4.9*	6.5	
	6 m	-	-	-	-	-	-	-	-	-	-	-	3.5	3.9	4.4*	4.4*	2.4	2.6	3.7	4.9*	2.3	2.6	3.6	4.6*	7.6	
	4.5 m	-	-	-	-	-	-	-	5.1*	5.1*	5.1*	5.1*	3.4	3.8	4.9*	4.9*	2.4	2.6	3.7	4.9*	2.0	2.2	3.1	4.4*	8.2	
	3 m	-	-	-	-	-	-	-	4.8	5.4	7.2*	7.2*	3.2	3.5	5.0	5.9*	2.3	2.5	3.5	5.4*	1.8	2.0	2.9	4.4*	8.6	
	1.5 m	-	-	-	-	-	-	-	4.3	4.8	7.1	9.4*	2.9	3.3	4.7	7.0*	2.1	2.4	3.4	5.9*	1.7	1.9	2.8	4.6*	8.7	
	0 m	-	-	-	-	-	-	-	3.9	4.5	6.7	10.9*	2.7	3.1	4.5	7.9*	2.0	2.3	3.3	5.8	1.7	2.0	2.8	4.9	8.5	
-1.5 m	-	-	-	-	6.7	7.9	9.4*	9.4*	3.8	4.4	6.6	11.5*	2.6	3.0	4.4	8.2	2.0	2.3	3.3	5.8	1.8	2.1	3.0	5.3	8.0	
-3 m	-	-	-	-	6.8	8.0	13.1	15.5*	3.8	4.4	6.6	11.3*	2.6	3.0	4.4	8.2	-	-	-	-	2.2	2.4	3.5	6.3	7.1	
-4.5 m	-	-	-	-	-	-	-	-	4.0	4.5	6.8	9.8*	-	-	-	-	-	-	-	-	3.3	3.8	5.5	8.3*	5.2	



Notes:

1. Working pressure with Power Boost = 37.5 MPa.
2. The above values are in compliance with ISO standard 10 567. They do not exceed 87 % of hydraulic lifting capacity or 75 % of tipping load, with the machine on firm, level ground.
3. Load capacities marked with an asterisk (\*) are limited by machine's hydraulic lifting capacity rather than tipping load.

# VOLVO EW210D LIFTING CAPACITY.

At the arm end, without bucket and quick fit. Unit: 1 000 kg. **With heavy counterweight.**

For lifting capacity including bucket/quick fit, simply subtract actual weight of those parts from the following values.

 Across under-carriage  Along under-carriage	Arm end (bucket pivot) related to ground level	Reach from machine centre (u = support up/d = support down)																Max.						
		1.5 m		3 m		4.5 m		6 m		7.5 m		Max.												
		u	d	u	d	u	d	u	d	u	d	u	d	u	d	u	d		u	d	m			
5.6 m mono boom	7.5 m	-	-	-	-	-	-	-	-	-	-	-	-	-	-	-	-	-	-	4.3	5.2*	5.2*	5.2*	5.6
	6 m	-	-	-	-	-	-	-	-	-	-	-	-	-	-	-	-	-	-	3.1	4.8*	4.5	4.8*	6.9
	4.5 m	-	-	-	-	-	-	-	-	-	-	-	-	-	-	-	-	-	-	2.5	4.1	3.7	4.8*	7.6
	2.45 m	-	-	-	-	-	-	-	-	-	-	-	-	-	-	-	-	-	-	2.3	3.7	3.4	4.9*	8.0
	dipper arm	-	-	-	-	-	-	-	-	-	-	-	-	-	-	-	-	-	-	2.2	3.6	3.2	5.3*	8.1
	Front dozer blade	-	-	-	-	-	-	-	-	-	-	-	-	-	-	-	-	-	-	2.2	3.7	3.3	6.1*	7.9
	Rear outriggers	-	-	-	-	-	-	-	-	-	-	-	-	-	-	-	-	-	-	2.4	4.1	3.6	6.9*	7.3
		-	-	-	-	-	-	-	-	-	-	-	-	-	-	-	-	-	-	2.9	5.0	4.4	7.0*	6.4
5.6 m mono boom	7.5 m	-	-	-	-	-	-	-	-	-	-	-	-	-	-	-	-	-	-	4.1	4.8*	4.8*	4.8*	5.8
	6 m	-	-	-	-	-	-	-	-	-	-	-	-	-	-	-	-	-	-	3.0	4.5*	4.3	4.5*	7.0
	4.5 m	-	-	-	-	-	-	-	-	-	-	-	-	-	-	-	-	-	-	2.4	4.0	3.6	4.4*	7.8
	2.6 m	-	-	-	-	-	-	-	-	-	-	-	-	-	-	-	-	-	-	2.2	3.6	3.3	4.6*	8.1
	dipper arm	-	-	-	-	-	-	-	-	-	-	-	-	-	-	-	-	-	-	2.1	3.5	3.1	5.0*	8.2
	Front dozer blade	-	-	-	-	-	-	-	-	-	-	-	-	-	-	-	-	-	-	2.1	3.6	3.2	5.6*	8.0
	Rear outriggers	-	-	-	-	-	-	-	-	-	-	-	-	-	-	-	-	-	-	2.3	3.9	3.5	6.7*	7.5
		-	-	-	-	-	-	-	-	-	-	-	-	-	-	-	-	-	-	2.8	4.7	4.2	6.9*	6.6
5.6 m mono boom	7.5 m	-	-	-	-	-	-	-	-	-	-	-	-	-	-	-	-	-	-	3.7	4.3*	4.3*	4.3*	6.2
	6 m	-	-	-	-	-	-	-	-	-	-	-	-	-	-	-	-	-	-	2.8	4.0*	4.0*	4.0*	7.4
	4.5 m	-	-	-	-	-	-	-	-	-	-	-	-	-	-	-	-	-	-	2.3	3.8	3.4	3.9*	8.1
	2.9 m	-	-	-	-	-	-	-	-	-	-	-	-	-	-	-	-	-	-	2.1	3.5	3.1	4.0*	8.4
	dipper arm	-	-	-	-	-	-	-	-	-	-	-	-	-	-	-	-	-	-	2.0	3.4	3.0	4.4*	8.5
	Front dozer blade	-	-	-	-	-	-	-	-	-	-	-	-	-	-	-	-	-	-	2.0	3.4	3.1	4.9*	8.3
	Rear outriggers	-	-	-	-	-	-	-	-	-	-	-	-	-	-	-	-	-	-	2.2	3.7	3.3	5.9*	7.8
		-	-	-	-	-	-	-	-	-	-	-	-	-	-	-	-	-	-	2.6	4.4	3.9	6.7*	6.9
5.6 m mono boom	7.5 m	-	-	-	-	-	-	-	-	-	-	-	-	-	-	-	-	-	-	3.5	5.4	4.9	5.7*	6.8
	6 m	-	-	-	-	-	-	-	-	-	-	-	-	-	-	-	-	-	-	2.7	4.3	3.9	5.4*	7.8
	4.5 m	-	-	-	-	-	-	-	-	-	-	-	-	-	-	-	-	-	-	2.4	3.7	3.4	5.3*	8.5
	3.2 m	-	-	-	-	-	-	-	-	-	-	-	-	-	-	-	-	-	-	2.2	3.4	3.1	5.3*	8.8
	dipper arm for grab	-	-	-	-	-	-	-	-	-	-	-	-	-	-	-	-	-	-	2.1	3.3	3.0	5.6*	8.9
	Front dozer blade	-	-	-	-	-	-	-	-	-	-	-	-	-	-	-	-	-	-	2.1	3.4	3.1	6.1	8.7
	Rear outriggers	-	-	-	-	-	-	-	-	-	-	-	-	-	-	-	-	-	-	2.2	3.6	3.3	6.4*	8.2
		-	-	-	-	-	-	-	-	-	-	-	-	-	-	-	-	-	-	2.6	4.2	3.8	6.5*	7.4
5.6 m mono boom	7.5 m	-	-	-	-	-	-	-	-	-	-	-	-	-	-	-	-	-	-	4.3	5.2*	5.2*	5.2*	5.6
	6 m	-	-	-	-	-	-	-	-	-	-	-	-	-	-	-	-	-	-	3.1	4.8*	4.5	4.8*	6.9
	4.5 m	-	-	-	-	-	-	-	-	-	-	-	-	-	-	-	-	-	-	2.6	4.8*	3.8	4.8*	7.6
	2.45 m	-	-	-	-	-	-	-	-	-	-	-	-	-	-	-	-	-	-	2.6	5.2	3.9	5.9*	8.0
	dipper arm	-	-	-	-	-	-	-	-	-	-	-	-	-	-	-	-	-	-	2.3	4.6	3.4	4.9*	8.0
	Outriggers front and rear	-	-	-	-	-	-	-	-	-	-	-	-	-	-	-	-	-	-	2.2	4.5	3.3	5.3*	8.1
	Rear outriggers	-	-	-	-	-	-	-	-	-	-	-	-	-	-	-	-	-	-	2.4	4.6	3.4	6.1*	7.9
		-	-	-	-	-	-	-	-	-	-	-	-	-	-	-	-	-	-	2.4	5.1	3.7	6.9*	7.3
5.6 m mono boom	7.5 m	-	-	-	-	-	-	-	-	-	-	-	-	-	-	-	-	-	-	4.1	4.8*	4.8*	4.8*	5.8
	6 m	-	-	-	-	-	-	-	-	-	-	-	-	-	-	-	-	-	-	3.0	4.5*	4.4	4.5*	7.0
	4.5 m	-	-	-	-	-	-	-	-	-	-	-	-	-	-	-	-	-	-	2.5	4.4*	3.7	4.4*	7.8
	2.6 m	-	-	-	-	-	-	-	-	-	-	-	-	-	-	-	-	-	-	2.2	4.5	3.3	4.6*	8.1
	dipper arm	-	-	-	-	-	-	-	-	-	-	-	-	-	-	-	-	-	-	2.1	4.4	3.2	5.0*	8.2
	Outriggers front and rear	-	-	-	-	-	-	-	-	-	-	-	-	-	-	-	-	-	-	2.1	4.4	3.3	5.6*	8.0
	Rear outriggers	-	-	-	-	-	-	-	-	-	-	-	-	-	-	-	-	-	-	2.3	4.9	3.6	6.7*	7.5
		-	-	-	-	-	-	-	-	-	-	-	-	-	-	-	-	-	-	2.8	6.0	4.3	6.9*	6.6

Notes:

- Working pressure with Power Boost = 37.5 MPa.
- The above values are in compliance with ISO standard 10 567. They do not exceed 87 % of hydraulic lifting capacity or 75 % of tipping load, with the machine on firm, level ground.
- Load capacities marked with an asterisk (\*) are limited by machine's hydraulic lifting capacity rather than tipping load.











At the arm end, without bucket and quick fit. Unit: 1 000 kg. **With heavy counterweight.**  
 For lifting capacity including bucket/quick fit, simply subtract actual weight of those parts from the following values.

 Across under-carriage  Along under-carriage	Arm end (bucket pivot) related to ground level	Reach from machine centre (u = support up/d = support down)																Max.								
		1.5 m		3 m		4.5 m		6 m		7.5 m		Max.														
		u	d	u	d	u	d	u	d	u	d	u	d	u	d	u	d		u	d	m					
5.5 m 2-piece boom 2.9 m dipper arm Outriggers front and rear	9 m	-	-	-	-	-	-	-	-	-	-	-	-	-	-	-	-	-	-	5.4*	5.4*	5.4*	5.4*	4.3		
	7.5 m	-	-	-	-	-	-	-	5.0*	5.0*	5.0*	5.0*	4.1	5.5*	5.5*	5.5*	-	-	-	-	3.8	4.3*	4.3*	4.3*	6.3	
	6 m	-	-	-	-	-	-	-	5.3*	5.3*	5.3*	5.3*	4.1	5.3*	5.3*	5.3*	-	-	-	-	2.8	4.0*	4.0*	4.0*	7.4	
	4.5 m	-	-	-	-	8.4*	8.4*	8.4*	8.4*	6.1	6.7*	6.7*	6.7*	3.9	5.9*	5.7	5.9*	2.7	5.4	4.0	5.6*	2.4	3.9*	3.5	3.9*	8.1
	3 m	-	-	-	-	-	-	-	5.5	8.9*	8.4	8.9*	3.7	6.9*	5.5	6.9*	2.6	5.3	3.9	6.0*	2.1	3.9*	3.2	3.9*	8.4	
	1.5 m	-	-	-	-	-	-	-	5.0	10.9*	7.8	10.9*	3.4	7.2	5.2	7.9*	2.5	5.1	3.8	6.5*	2.0	4.1*	3.1	4.1*	8.5	
	0 m	-	-	-	-	-	-	-	4.7	10.9	7.5	12.1*	3.2	6.9	5.0	8.7*	2.4	5.0	3.6	6.9*	2.1	4.3	3.2	4.6*	8.3	
	-1.5 m	-	-	-	-	8.3*	11.0*	11.0*	11.0*	4.6	10.8	7.4	12.2*	3.1	6.8	4.9	8.9*	2.3	4.9	3.6	6.9*	2.2	4.7	3.4	5.3*	7.8
-3 m	-	-	-	-	8.5	16.6*	14.8	16.6*	4.6	10.8	7.4	11.4*	3.1	6.9	4.9	8.3*	-	-	-	-	2.6	5.6	4.1	6.8*	6.9	
5.5 m 2-piece boom 3.2 m Grab Arm Outriggers front and rear	9 m	-	-	-	-	-	-	-	5.7*	5.7*	5.7*	5.7*	-	-	-	-	-	-	-	-	5.5	6.1*	6.1*	6.1*	5.0	
	7.5 m	-	-	-	-	-	-	-	-	-	-	-	4.4	5.3*	5.3*	5.3*	-	-	-	-	3.5	5.7*	5.0	5.7*	6.8	
	6 m	-	-	-	-	-	-	-	-	-	-	-	4.3	5.2*	5.2*	5.2*	3.0	5.5*	4.3	5.5*	2.8	5.3	4.0	5.4*	7.8	
	4.5 m	-	-	-	-	-	-	-	6.4	6.4*	6.4*	6.4*	4.2	5.9*	5.9*	5.9*	3.0	5.6*	4.3	5.6*	2.4	4.6	3.5	5.2*	8.5	
	3 m	-	-	-	-	-	-	-	-	-	-	-	3.9	6.9*	5.7	6.9*	2.8	5.5	4.1	6.1*	2.2	4.3	3.2	5.2*	8.8	
	1.5 m	-	-	-	-	-	-	-	-	-	-	-	3.7	7.4	5.4	8.0*	2.7	5.4	4.0	6.6*	2.1	4.2	3.1	5.4*	8.9	
	0 m	-	-	-	-	-	-	-	4.9	11.2	7.7	12.1*	3.4	7.2	5.2	8.8*	2.6	5.2	3.9	7.0*	2.1	4.3	3.2	5.8*	8.7	
	-1.5 m	-	-	-	-	-	-	-	4.8	11.0	7.6	12.5*	3.3	7.0	5.1	9.1*	2.5	5.2	3.8	7.2*	2.3	4.6	3.4	6.4*	8.2	
-3 m	-	-	-	-	8.6	15.9*	14.9	15.9*	4.8	11.0	7.6	11.9*	3.3	7.0	5.1	8.8*	-	-	-	-	2.6	5.3	3.9	6.6*	7.4	
5.5 m 2-piece boom 2.45 m dipper arm Blade rear	9 m	-	-	-	-	-	-	-	-	-	-	-	-	-	-	-	-	-	-	-	7.2*	7.2*	7.2*	7.2*	3.3	
	7.5 m	-	-	-	-	-	-	-	5.8*	5.8*	5.8*	5.8*	-	-	-	-	-	-	-	-	4.1	4.6	5.4*	5.4*	5.6	
	6 m	-	-	-	-	-	-	-	6.0	6.0*	6.0*	6.0*	3.8	4.2	5.6	5.8*	-	-	-	-	2.9	3.2	4.4	4.8*	6.9	
	4.5 m	-	-	-	-	10.2*	10.2*	10.2*	10.2*	5.6	6.2	7.4*	7.4*	3.6	4.0	5.5	6.4*	2.5	2.8	3.8	6.0*	2.4	2.7	3.7	4.7*	7.6
	3 m	-	-	-	-	-	-	-	5.0	5.7	8.0	9.6*	3.4	3.8	5.2	7.3*	2.4	2.7	3.7	6.3*	2.1	2.4	3.3	4.8*	8.0	
	1.5 m	-	-	-	-	-	-	-	4.6	5.2	7.4	11.4*	3.1	3.5	5.0	8.2*	2.3	2.6	3.6	6.7*	2.0	2.3	3.2	5.1*	8.1	
	0 m	-	-	-	-	-	-	-	4.3	4.9	7.2	12.2*	3.0	3.4	4.8	8.8*	2.2	2.5	3.5	6.8	2.1	2.3	3.3	5.6*	7.9	
	-1.5 m	-	-	-	-	7.8*	9.1	11.8*	11.8*	4.3	4.9	7.1	12.1*	2.9	3.3	4.7	8.8*	-	-	-	-	2.3	2.5	3.6	6.7*	7.3
-3 m	-	-	-	-	-	-	-	4.4	5.0	7.2	10.9*	3.0	3.4	4.8	7.9*	-	-	-	-	-	2.8	3.1	4.4	7.1*	6.4	
5.5 m 2-piece boom 2.6 m dipper arm Blade rear	9 m	-	-	-	-	-	-	-	-	-	-	-	-	-	-	-	-	-	-	-	6.5*	6.5*	6.5*	6.5*	3.7	
	7.5 m	-	-	-	-	-	-	-	5.5*	5.5*	5.5*	5.5*	-	-	-	-	-	-	-	-	3.9	4.3	5.0*	5.0*	5.9	
	6 m	-	-	-	-	-	-	-	5.8*	5.8*	5.8*	5.8*	3.8	4.2	5.7	5.7*	-	-	-	-	2.8	3.1	4.3	4.5*	7.1	
	4.5 m	-	-	-	-	9.6*	9.6*	9.6*	9.6*	5.7	6.3	7.2*	7.2*	3.6	4.0	5.5	6.2*	2.5	2.8	3.8	5.9*	2.3	2.6	3.6	4.4*	7.8
	3 m	-	-	-	-	-	-	-	5.1	5.7	8.0	9.3*	3.4	3.8	5.2	7.2*	2.4	2.7	3.7	6.2*	2.1	2.3	3.3	4.4*	8.1	
	1.5 m	-	-	-	-	-	-	-	4.6	5.2	7.5	11.3*	3.1	3.5	5.0	8.1*	2.3	2.6	3.6	6.7*	2.0	2.2	3.1	4.7*	8.2	
	0 m	-	-	-	-	-	-	-	4.3	4.9	7.2	12.2*	3.0	3.4	4.8	8.8*	2.2	2.5	3.5	6.8	2.0	2.3	3.2	5.2*	8.0	
	-1.5 m	-	-	-	-	7.8*	9.1	11.5*	11.5*	4.3	4.9	7.1	12.1*	2.9	3.3	4.7	8.9*	-	-	-	-	2.2	2.5	3.5	6.2*	7.5
-3 m	-	-	-	-	-	-	-	4.3	4.9	7.2	11.1*	3.0	3.3	4.8	8.1*	-	-	-	-	-	2.6	3.0	4.2	7.0*	6.6	
5.5 m 2-piece boom 2.9 m dipper arm Blade rear	9 m	-	-	-	-	-	-	-	-	-	-	-	-	-	-	-	-	-	-	-	5.4*	5.4*	5.4*	5.4*	4.3	
	7.5 m	-	-	-	-	-	-	-	5.0*	5.0*	5.0*	5.0*	3.8	4.2	5.5*	5.5*	-	-	-	-	3.5	3.9	4.3*	4.3*	6.3	
	6 m	-	-	-	-	-	-	-	5.3*	5.3*	5.3*	5.3*	3.8	4.2	5.3*	5.3*	-	-	-	-	2.6	2.9	4.0*	4.0*	7.4	
	4.5 m	-	-	-	-	8.4*	8.4*	8.4*	8.4*	5.8	6.4	6.7*	6.7*	3.7	4.1	5.6	5.9*	2.5	2.8	3.9	5.6*	2.2	2.5	3.4	3.9*	8.1
	3 m	-	-	-	-	-	-	-	5.2	5.8	8.2	8.9*	3.4	3.8	5.3	6.9*	2.4	2.7	3.8	6.0*	2.0	2.2	3.1	3.9*	8.4	
	1.5 m	-	-	-	-	-	-	-	4.7	5.3	7.6	10.9*	3.2	3.6	5.0	7.9*	2.3	2.6	3.6	6.5*	1.9	2.1	3.0	4.1*	8.5	
	0 m	-	-	-	-	-	-	-	4.4	5.0	7.2	12.1*	3.0	3.4	4.8	8.7*	2.2	2.5	3.5	6.8	1.9	2.1	3.0	4.6*	8.3	
	-1.5 m	-	-	-	-	7.7*	9.0	11.0*	11.0*	4.3	4.9	7.1	12.2*	2.9	3.3	4.7	8.9*	2.2	2.4	3.5	6.7	2.1	2.3	3.3	5.3*	7.8
-3 m	-	-	-	-	7.9	9.1	14.3	16.6*	4.3	4.9	7.2	11.4*	2.9	3.3	4.7	8.3*	-	-	-	-	2.4	2.8	3.9	6.8*	6.9	
5.5 m 2-piece boom 3.2 m Grab Arm Blade rear	9 m	-	-	-	-	-	-	-	5.7*	5.7*	5.7*	5.7*	-	-	-	-	-	-	-	-	5.2	5.8	6.1*	6.1*	5.0	
	7.5 m	-	-	-	-	-	-	-	-	-	-	-	4.1	4.5	5.3*	5.3*	-	-	-	-	3.3	3.7	4.9	5.7*	6.8	
	6 m	-	-	-	-	-	-	-	-	-	-	-	4.1	4.5	5.2*	5.2*	2.8	3.1	4.2	5.5*	2.6	2.9	3.9	5.4*	7.8	
	4.5 m	-	-	-	-	-	-	-	6.1	6.4*	6.4*	6.4*	4.0	4.4	5.8	5.9*	2.8	3.1	4.1	5.6*	2.2	2.5	3.4	5.2*	8.5	
	3 m	-	-	-	-	-	-	-	-	-	-	-	3.7	4.1	5.6	6.9*	2.7	3.0	4.0	6.1*	2.0	2.3	3.1	5.2*	8.8	
	1.5 m	-	-	-	-	-	-	-	-	-	-	-	3.4	3.8	5.3	8.0*	2.5	2.8	3.9	6.6*	2.0	2.2	3.0	5.4*	8.9	
	0 m	-	-	-	-	-	-	-	4.6	5.2	7.5	12.1*	3.2	3.6	5.0	8.8*	2.4	2.7	3.7	7.0	2.0	2.2	3.1	5.6	8.7	
	-1.5 m	-	-	-	-	-	-	-	4.5	5.1	7.3	12.5*	3.1	3.5	4.9	9.1*	2.4	2.6	3.7	6.9	2.1	2.4	3.3	6.1	8.2	
-3 m	-	-	-	-	8.0	9.3	14.4	15.9*	4.5	5.1	7.3	11.9*	3.1	3.5	4.9	8.8*	-	-	-	-	2.4	2.7	3.8	6.6*	7.4	



Notes:

- Working pressure with Power Boost = 37.5 MPa.
- The above values are in compliance with ISO standard 10 567. They do not exceed 87 % of hydraulic lifting capacity or 75 % of tipping load, with the machine on firm, level ground.
- Load capacities marked with an asterisk (\*) are limited by machine's hydraulic lifting capacity rather than tipping load.

# VOLVO EW210D LIFTING CAPACITY.

At the arm end, without bucket and quick fit. Unit: 1 000 kg. **With light counterweight.**



For lifting capacity including bucket/quick fit, simply subtract actual weight of those parts from the following values.

 Across under-carriage  Along under-carriage	Arm end (bucket pivot) related to ground level	Reach from machine centre (u = support up/d = support down)																Max.									
		1.5 m		3 m		4.5 m		6 m		7.5 m		Max.															
		u	d	u	d	u	d	u	d	u	d	u	d	u	d	u	d		u	d							
5.5 m 2-piece boom 2.45 m dipper arm Front dozer blade Rear outriggers	9 m	-	-	-	-	-	-	-	-	-	-	-	-	-	-	-	-	-	7.2*	7.2*	7.2*	7.2*	3.3				
	7.5 m	-	-	-	-	-	-	-	5.8*	5.8*	5.8*	5.8*	-	-	-	-	-	-	3.9	5.4*	5.4*	5.4*	5.6				
	6 m	-	-	-	-	-	-	-	5.8	6.0*	6.0*	6.0*	3.6	5.8*	5.3	5.8*	-	-	-	2.8	4.6	4.1	4.8*	6.9			
	4.5 m	-	-	-	-	10.0	10.2*	10.2*	10.2*	5.4	7.4*	7.4*	7.4*	3.5	5.7	5.1	6.4*	2.4	3.9	3.5	6.0*	2.3	3.8	3.4	4.7*	7.6	
	3 m	-	-	-	-	-	-	-	-	4.8	8.5	7.5	9.6*	3.2	5.4	4.9	7.3*	2.3	3.9	3.5	6.3*	2.0	3.5	3.1	4.8*	8.0	
	1.5 m	-	-	-	-	-	-	-	-	4.3	7.9	6.9	11.4*	3.0	5.2	4.6	8.2*	2.2	3.7	3.3	6.7*	1.9	3.3	3.0	5.1*	8.1	
	0 m	-	-	-	-	-	-	-	-	4.1	7.6	6.7	12.2*	2.8	5.0	4.4	8.8*	2.1	3.6	3.2	7.0*	1.9	3.4	3.0	5.6*	7.9	
	-3 m	-	-	-	-	7.5*	11.8*	11.8*	11.8*	4.1	7.6	6.6	12.1*	2.8	4.9	4.4	8.8*	-	-	-	-	2.1	3.8	3.3	6.7*	7.3	
5.5 m 2-piece boom 2.6 m dipper arm Front dozer blade Rear outriggers	9 m	-	-	-	-	-	-	-	-	-	-	-	-	-	-	-	-	-	-	-	-	-	-	-	-		
	7.5 m	-	-	-	-	-	-	-	5.5*	5.5*	5.5*	5.5*	-	-	-	-	-	-	-	-	-	-	-	-	-		
	6 m	-	-	-	-	-	-	-	5.8*	5.8*	5.8*	5.8*	3.6	5.7*	5.3	5.7*	-	-	-	-	-	-	-	-	-		
	4.5 m	-	-	-	-	9.6*	9.6*	9.6*	9.6*	5.4	7.2*	7.2*	7.2*	3.5	5.7	5.2	6.2*	2.4	4.0	3.6	5.9*	2.2	3.7	3.3	4.4*	7.8	
	3 m	-	-	-	-	-	-	-	-	4.9	8.5	7.5	9.3*	3.2	5.5	4.9	7.2*	2.3	3.9	3.5	6.2*	2.0	3.4	3.0	4.4*	8.1	
	1.5 m	-	-	-	-	-	-	-	-	4.4	7.9	7.0	11.3*	3.0	5.2	4.6	8.1*	2.2	3.7	3.3	6.7*	1.9	3.2	2.9	4.7*	8.2	
	0 m	-	-	-	-	-	-	-	-	4.1	7.6	6.7	12.2*	2.8	5.0	4.4	8.8*	2.1	3.6	3.2	7.0*	1.9	3.3	3.0	5.2*	8.0	
	-3 m	-	-	-	-	7.4*	11.5*	11.5*	11.5*	4.1	7.6	6.6	12.1*	2.7	4.9	4.4	8.9*	-	-	-	-	2.1	3.6	3.2	6.2*	7.5	
5.5 m 2-piece boom 2.9 m dipper arm Front dozer blade Rear outriggers	9 m	-	-	-	-	-	-	-	-	-	-	-	-	-	-	-	-	-	-	-	-	-	-	-	-		
	7.5 m	-	-	-	-	-	-	-	5.0*	5.0*	5.0*	5.0*	3.7	5.5*	5.4	5.5*	-	-	-	-	-	-	-	-	-		
	6 m	-	-	-	-	-	-	-	5.3*	5.3*	5.3*	5.3*	3.7	5.3*	5.3*	5.3*	-	-	-	-	-	-	-	-	-		
	4.5 m	-	-	-	-	8.4*	8.4*	8.4*	8.4*	5.5	6.7*	6.7*	6.7*	3.5	5.8	5.2	5.9*	2.4	4.0	3.6	5.6*	2.1	3.5	3.2	3.9*	8.1	
	3 m	-	-	-	-	-	-	-	-	5.0	8.7	7.7	8.9*	3.3	5.5	4.9	6.9*	2.3	3.9	3.5	6.0*	1.9	3.2	2.9	3.9*	8.4	
	1.5 m	-	-	-	-	-	-	-	-	4.4	8.0	7.1	10.9*	3.0	5.2	4.7	7.9*	2.2	3.8	3.4	6.5*	1.8	3.1	2.8	4.1*	8.5	
	0 m	-	-	-	-	-	-	-	-	4.1	7.7	6.7	12.1*	2.8	5.0	4.5	8.7*	2.1	3.6	3.2	6.9*	1.8	3.1	2.8	4.6*	8.3	
	-3 m	-	-	-	-	7.4*	11.0*	11.0*	11.0*	4.0	7.6	6.6	12.2*	2.7	4.9	4.4	8.9*	2.0	3.6	3.2	6.9*	1.9	3.4	3.0	5.3*	7.8	
5.5 m 2-piece boom 3.2 m Grab Arm Front dozer blade Rear outriggers	9 m	-	-	-	-	-	-	-	5.7*	5.7*	5.7*	5.7*	-	-	-	-	-	-	-	-	-	-	-	-	-		
	7.5 m	-	-	-	-	-	-	-	-	-	-	-	-	-	-	-	-	-	-	-	-	-	-	-	-		
	6 m	-	-	-	-	-	-	-	-	-	-	-	-	-	-	-	-	-	-	-	-	-	-	-	-		
	4.5 m	-	-	-	-	-	-	-	5.9	6.4*	6.4*	6.4*	3.8	5.9*	5.5	5.9*	2.7	4.3	3.9	5.6*	2.1	3.5	3.1	5.2*	8.5		
	3 m	-	-	-	-	-	-	-	-	-	-	-	-	-	3.5	5.8	5.2	6.9*	2.5	4.1	3.7	6.1*	1.9	3.2	2.9	5.2*	8.8
	1.5 m	-	-	-	-	-	-	-	-	-	-	-	-	-	3.3	5.5	4.9	8.0*	2.4	4.0	3.6	6.6*	1.9	3.1	2.8	5.4*	8.9
	0 m	-	-	-	-	-	-	-	-	4.4	7.9	7.0	12.1*	3.1	5.3	4.7	8.8*	2.3	3.9	3.5	7.0*	1.9	3.2	2.8	5.8	8.7	
	-3 m	-	-	-	-	7.6	15.9*	13.4	15.9*	4.3	7.8	6.8	11.9*	2.9	5.1	4.6	8.8*	-	-	-	-	2.3	3.9	3.5	6.6*	7.4	
5.5 m 2-piece boom 2.45 m dipper arm Outriggers front and rear	9 m	-	-	-	-	-	-	-	-	-	-	-	-	-	-	-	-	-	-	-	-	-	-	-	-		
	7.5 m	-	-	-	-	-	-	-	5.8*	5.8*	5.8*	5.8*	-	-	-	-	-	-	-	-	-	-	-	-	-		
	6 m	-	-	-	-	-	-	-	5.8	6.0*	6.0*	6.0*	3.6	5.8*	5.4	5.8*	-	-	-	-	-	-	-	-	-		
	4.5 m	-	-	-	-	10.1	10.2*	10.2*	10.2*	5.4	7.4*	7.4*	7.4*	3.5	6.4*	5.2	6.4*	2.4	4.9	3.6	6.0*	2.3	4.7*	3.5	4.7*	7.6	
	3 m	-	-	-	-	-	-	-	-	4.9	9.6*	7.6	9.6*	3.3	6.9	5.0	7.3*	2.3	4.8	3.5	6.3*	2.0	4.3	3.2	4.8*	8.0	
	1.5 m	-	-	-	-	-	-	-	-	4.4	10.4	7.1	11.4*	3.0	6.6	4.7	8.2*	2.2	4.7	3.4	6.7*	1.9	4.2	3.0	5.1*	8.1	
	0 m	-	-	-	-	-	-	-	-	4.2	10.1	6.8	12.2*	2.9	6.4	4.5	8.8*	2.1	4.6	3.3	7.0*	2.0	4.3	3.1	5.6*	7.9	
	-3 m	-	-	-	-	7.6*	11.8*	11.8*	11.8*	4.1	10.0	6.8	12.1*	2.8	6.3	4.5	8.8*	-	-	-	-	2.2	4.8	3.4	6.7*	7.3	
5.5 m 2-piece boom 2.6 m dipper arm Outriggers front and rear	9 m	-	-	-	-	-	-	-	-	-	-	-	-	-	-	-	-	-	-	-	-	-	-	-	-		
	7.5 m	-	-	-	-	-	-	-	5.5*	5.5*	5.5*	5.5*	-	-	-	-	-	-	-	-	-	-	-	-	-		
	6 m	-	-	-	-	-	-	-	5.8*	5.8*	5.8*	5.8*	3.7	5.7*	5.4	5.7*	-	-	-	-	-	-	-	-	-		
	4.5 m	-	-	-	-	9.6*	9.6*	9.6*	9.6*	5.5	7.2*	7.2*	7.2*	3.5	5.8	5.3	6.2*	2.4	4.0	3.6	5.9*	2.2	3.7	3.4	4.4*	7.8	
	3 m	-	-	-	-	-	-	-	-	4.9	8.6	7.7	9.3*	3.3	5.5	5.0	7.2*	2.3	3.9	3.5	6.2*	2.0	3.4	3.1	4.4*	8.1	
	1.5 m	-	-	-	-	-	-	-	-	4.4	8.0	7.1	11.3*	3.0	5.2	4.7	8.1*	2.2	3.8	3.4	6.7*	1.9	3.3	3.0	4.7*	8.2	
	0 m	-	-	-	-	-	-	-	-	4.2	7.7	6.8	12.2*	2.9	5.0	4.5	8.8*	2.1	3.7	3.3	7.0*	1.9	3.3	3.0	5.2*	8.0	
	-3 m	-	-	-	-	7.5*	11.5*	11.5*	11.5*	4.1	7.6	6.8	12.1*	2.8	4.9	4.5	8.9*	-	-	-	-	2.1	3.7	3.3	6.2*	7.5	

**Notes:**

- Working pressure with Power Boost = 37.5 MPa.
- The above values are in compliance with ISO standard 10 567. They do not exceed 87 % of hydraulic lifting capacity or 75 % of tipping load, with the machine on firm, level ground.
- Load capacities marked with an asterisk (\*) are limited by machine's hydraulic lifting capacity rather than tipping load.

At the arm end, without bucket and quick fit. Unit: 1 000 kg. **With light counterweight.**  
 For lifting capacity including bucket/quick fit, simply subtract actual weight of those parts from the following values.

 Across under-carriage  Along under-carriage	Arm end (bucket pivot) related to ground level	Reach from machine centre (u = support up/d = support down)																Max. m								
		1.5 m		3 m		4.5 m		6 m		7.5 m		Max.														
		u	d	u	d	u	d	u	d	u	d	u	d	u	d	u	d									
5.5 m 2-piece boom 2.9 m dipper arm Outriggers front and rear	9 m	-	-	-	-	-	-	-	-	-	-	-	-	-	-	-	-	-	-	-	5.4*	5.4*	5.4*	5.4*	4.3	
	7.5 m	-	-	-	-	-	-	-	5.0*	5.0*	5.0*	5.0*	3.7	5.5*	5.5	5.5*	-	-	-	-	3.4	4.3*	4.3*	4.3*	6.3	
	6 m	-	-	-	-	-	-	-	5.3*	5.3*	5.3*	5.3*	3.7	5.3*	5.3*	5.3*	-	-	-	-	2.5	4.0*	3.8	4.0*	7.4	
	4.5 m	-	-	-	-	8.4*	8.4*	8.4*	8.4*	5.6	6.7*	6.7*	6.7*	3.6	5.9*	5.3	5.9*	2.4	5.0	3.7	5.6*	2.1	3.9*	3.2	3.9*	8.1
	3 m	-	-	-	-	-	-	-	5.0	8.9*	7.8	8.9*	3.3	6.9*	5.0	6.9*	2.3	4.9	3.6	6.0*	1.9	3.9*	2.9	3.9*	8.4	
	1.5 m	-	-	-	-	-	-	-	4.5	10.5	7.2	10.9*	3.1	6.7	4.8	7.9*	2.2	4.7	3.4	6.5*	1.8	3.9	2.8	4.1*	8.5	
	0 m	-	-	-	-	-	-	-	4.2	10.1	6.9	12.1*	2.9	6.4	4.6	8.7*	2.1	4.6	3.3	6.9*	1.8	4.0	2.9	4.6*	8.3	
	-1.5 m	-	-	-	-	7.5*	11.0*	11.0*	11.0*	4.1	10.0	6.8	12.2*	2.8	6.3	4.5	8.9*	2.1	4.6	3.3	6.9*	2.0	4.3	3.1	5.3*	7.8
-3 m	-	-	-	-	7.6	16.6*	13.6	16.6*	4.1	10.0	6.8	11.4*	2.8	6.3	4.5	8.3*	-	-	-	2.3	5.2	3.7	6.8*	6.9		
5.5 m 2-piece boom 3.2 m Grab Arm Outriggers front and rear	9 m	-	-	-	-	-	-	-	5.7*	5.7*	5.7*	5.7*	-	-	-	-	-	-	-	-	5.1	6.1*	6.1*	6.1*	5.0	
	7.5 m	-	-	-	-	-	-	-	-	-	-	-	4.0	5.3*	5.3*	5.3*	-	-	-	-	3.2	5.7*	4.7	5.7*	6.8	
	6 m	-	-	-	-	-	-	-	-	-	-	-	4.0	5.2*	5.2*	5.2*	2.7	5.3	4.0	5.5*	2.5	4.9	3.7	5.4*	7.8	
	4.5 m	-	-	-	-	-	-	-	5.9	6.4*	6.4*	6.4*	3.8	5.9*	5.6	5.9*	2.7	5.3	3.9	5.6*	2.2	4.3	3.2	5.2*	8.5	
	3 m	-	-	-	-	-	-	-	-	-	-	-	3.6	6.9*	5.3	6.9*	2.6	5.1	3.8	6.1*	2.0	4.0	3.0	5.2*	8.8	
	1.5 m	-	-	-	-	-	-	-	-	-	-	-	3.3	6.9	5.0	8.0*	2.4	5.0	3.7	6.6*	1.9	3.9	2.9	5.4*	8.9	
	0 m	-	-	-	-	-	-	-	4.4	10.4	7.1	12.1*	3.1	6.7	4.8	8.8*	2.3	4.8	3.5	7.0*	1.9	3.9	2.9	5.8*	8.7	
	-1.5 m	-	-	-	-	-	-	-	4.3	10.2	7.0	12.5*	3.0	6.5	4.7	9.1*	2.3	4.8	3.5	7.2*	2.0	4.2	3.1	6.4*	8.2	
-3 m	-	-	-	-	7.7	15.9*	13.7	15.9*	4.3	10.2	7.0	11.9*	3.0	6.5	4.7	8.8*	-	-	-	2.4	4.9	3.6	6.6*	7.4		
5.5 m 2-piece boom 2.45 m dipper arm Blade rear	9 m	-	-	-	-	-	-	-	-	-	-	-	-	-	-	-	-	-	-	-	7.2*	7.2*	7.2*	7.2*	3.3	
	7.5 m	-	-	-	-	-	-	-	5.6	5.8*	5.8*	5.8*	-	-	-	-	-	-	-	-	3.7	4.2	5.4*	5.4*	5.6	
	6 m	-	-	-	-	-	-	-	5.5	6.0*	6.0*	6.0*	3.4	3.8	5.2	5.8*	-	-	-	-	2.6	2.9	4.1	4.8*	6.9	
	4.5 m	-	-	-	-	9.6	10.2*	10.2*	10.2*	5.1	5.7	7.4*	7.4*	3.3	3.6	5.1	6.4*	2.2	2.5	3.5	6.0*	2.1	2.4	3.4	4.7*	7.6
	3 m	-	-	-	-	-	-	-	4.6	5.1	7.4	9.6*	3.0	3.4	4.8	7.3*	2.1	2.4	3.4	6.3*	1.9	2.1	3.0	4.8*	8.0	
	1.5 m	-	-	-	-	-	-	-	4.1	4.6	6.8	11.4*	2.8	3.2	4.5	8.2*	2.0	2.3	3.3	6.4	1.8	2.0	2.9	5.1*	8.1	
	0 m	-	-	-	-	-	-	-	3.8	4.4	6.6	12.2*	2.6	3.0	4.4	8.8*	1.9	2.2	3.2	6.3	1.8	2.1	3.0	5.6*	7.9	
	-1.5 m	-	-	-	-	7.0*	8.2	11.8*	11.8*	3.8	4.4	6.5	12.1*	2.6	2.9	4.3	8.8*	-	-	-	2.0	2.3	3.3	6.5	7.3	
-3 m	-	-	-	-	-	-	-	3.9	4.4	6.6	10.9*	2.6	3.0	4.4	7.9*	-	-	-	-	2.4	2.8	4.0	7.1*	6.4		
5.5 m 2-piece boom 2.6 m dipper arm Blade rear	9 m	-	-	-	-	-	-	-	-	-	-	-	-	-	-	-	-	-	-	-	6.5*	6.5*	6.5*	6.5*	3.7	
	7.5 m	-	-	-	-	-	-	-	5.5*	5.5*	5.5*	5.5*	-	-	-	-	-	-	-	-	3.5	4.1	5.0*	5.0*	5.9	
	6 m	-	-	-	-	-	-	-	5.5	5.8*	5.8*	5.8*	3.4	4.0	5.2	5.7*	-	-	-	-	2.5	3.0	3.9	4.5*	7.1	
	4.5 m	-	-	-	-	9.6*	9.6*	9.6*	9.6*	5.2	6.1	7.2*	7.2*	3.3	3.9	5.1	6.2*	2.2	2.7	3.5	5.9*	2.1	2.5	3.3	4.4*	7.8
	3 m	-	-	-	-	-	-	-	4.6	5.5	7.4	9.3*	3.0	3.6	4.8	7.2*	2.1	2.6	3.4	6.2*	1.8	2.2	3.0	4.4*	8.1	
	1.5 m	-	-	-	-	-	-	-	4.1	5.0	6.9	11.3*	2.8	3.4	4.6	8.1*	2.0	2.4	3.3	6.7*	1.7	2.1	2.9	4.7*	8.2	
	0 m	-	-	-	-	-	-	-	3.9	4.7	6.6	12.2*	2.6	3.2	4.4	8.8*	1.9	2.3	3.2	7.0*	1.8	2.1	2.9	5.2*	8.0	
	-1.5 m	-	-	-	-	7.0*	8.6	11.5*	11.5*	3.8	4.6	6.5	12.1*	2.6	3.1	4.3	8.9*	-	-	-	1.9	2.3	3.2	6.2*	7.5	
-3 m	-	-	-	-	-	-	-	3.9	4.7	6.6	11.1*	2.6	3.2	4.3	8.1*	-	-	-	-	2.3	2.8	3.9	7.0*	6.6		
5.5 m 2-piece boom 2.9 m dipper arm Blade rear	9 m	-	-	-	-	-	-	-	-	-	-	-	-	-	-	-	-	-	-	-	5.4*	5.4*	5.4*	5.4*	4.3	
	7.5 m	-	-	-	-	-	-	-	5.0*	5.0*	5.0*	5.0*	3.5	4.1	5.3	5.5*	-	-	-	-	3.2	3.8	4.3*	4.3*	6.3	
	6 m	-	-	-	-	-	-	-	5.3*	5.3*	5.3*	5.3*	3.5	4.1	5.3	5.3*	-	-	-	-	2.4	2.8	3.7	4.0*	7.4	
	4.5 m	-	-	-	-	8.4*	8.4*	8.4*	8.4*	5.3	6.2	6.7*	6.7*	3.3	3.9	5.1	5.9*	2.3	2.7	3.6	5.6*	2.0	2.3	3.1	3.9*	8.1
	3 m	-	-	-	-	-	-	-	4.7	5.6	7.5	8.9*	3.1	3.7	4.9	6.9*	2.2	2.6	3.4	6.0*	1.7	2.1	2.8	3.9*	8.4	
	1.5 m	-	-	-	-	-	-	-	4.2	5.0	6.9	10.9*	2.8	3.4	4.6	7.9*	2.0	2.5	3.3	6.5*	1.6	2.0	2.7	4.1*	8.5	
	0 m	-	-	-	-	-	-	-	3.9	4.7	6.6	12.1*	2.6	3.2	4.4	8.7*	1.9	2.4	3.2	6.9*	1.7	2.0	2.8	4.6*	8.3	
	-1.5 m	-	-	-	-	6.9*	8.6	11.0*	11.0*	3.8	4.6	6.5	12.2*	2.6	3.1	4.3	8.9*	1.9	2.3	3.2	6.9*	1.8	2.2	3.0	5.3*	7.8
-3 m	-	-	-	-	7.0	8.7	13.1	16.6*	3.8	4.7	6.5	11.4*	2.6	3.1	4.3	8.3*	-	-	-	2.2	2.6	3.6	6.8*	6.9		
5.5 m 2-piece boom 3.2 m Grab Arm Blade rear	9 m	-	-	-	-	-	-	-	5.7*	5.7*	5.7*	5.7*	-	-	-	-	-	-	-	-	4.8	5.6	6.1*	6.1*	5.0	
	7.5 m	-	-	-	-	-	-	-	-	-	-	-	3.8	4.4	5.3*	5.3*	-	-	-	-	3.0	3.5	4.5	5.7*	6.8	
	6 m	-	-	-	-	-	-	-	-	-	-	-	3.8	4.4	5.2*	5.2*	2.6	3.0	3.9	5.5*	2.3	2.8	3.6	5.4*	7.8	
	4.5 m	-	-	-	-	-	-	-	5.6	6.4*	6.4*	6.4*	3.6	4.2	5.4	5.9*	2.5	2.9	3.8	5.6*	2.0	2.4	3.1	5.2*	8.5	
	3 m	-	-	-	-	-	-	-	-	-	-	-	3.4	3.9	5.1	6.9*	2.4	2.8	3.7	6.1*	1.8	2.2	2.8	5.2*	8.8	
	1.5 m	-	-	-	-	-	-	-	-	-	-	-	3.1	3.7	4.8	8.0*	2.3	2.7	3.5	6.6*	1.7	2.1	2.8	5.4*	8.9	
	0 m	-	-	-	-	-	-	-	4.1	5.0	6.9	12.1*	2.9	3.4	4.6	8.8*	2.1	2.6	3.4	7.0*	1.8	2.1	2.8	5.8	8.7	
	-1.5 m	-	-	-	-	-	-	-	4.0	4.8	6.7	12.5*	2.8	3.3	4.5	9.1*	2.1	2.5	3.4	7.1	1.9	2.3	3.0	6.2	8.2	
-3 m	-	-	-	-	7.2	8.9	13.2	15.9*	4.0	4.8	6.7	11.9*	2.8	3.3	4.5	8.8*	-	-	-	2.2	2.6	3.5	6.6*	7.4		

Notes:

- Working pressure with Power Boost = 37.5 MPa.
- The above values are in compliance with ISO standard 10 567. They do not exceed 87 % of hydraulic lifting capacity or 75 % of tipping load, with the machine on firm, level ground.
- Load capacities marked with an asterisk (\*) are limited by machine's hydraulic lifting capacity rather than tipping load.



# EQUIPMENT.

## STANDARD EQUIPMENT

### Engine

Turbocharged, 4 stroke Volvo diesel engine with water cooling, direct injection and charged air cooler that meets EU Step IIIB/ Tier4 emission requirements

Intake air pre-heater

ECO- Modus

Fuel filter and water separator

Fuel filler pump: 50 l/min with automatic shut-off

Aluminium core radiator

### Electric/Electronic control system

Contronics-computerized monitoring and diagnostic system

Master electrical disconnect switch

Adjustable automatic idling system

One-touch power boost

Adjustable monitor

Safety stop/start function

2 Frame mounted halogen lamps

Alternator, 120 A

Batteries, 2 x 12 V/140 Ah

Start motor, 24 V/5.5 kW

CareTrack via GSM

Rear view camera

### Undercarriage

2-speed power transmission plus creep speed

Oscillating front axle  $\pm 9^\circ$  with out mudguards/  $6^\circ$  with mudguards

2-circuit travel brakes

EAL extended axle lock (EW210D only)

Maintenance-free propeller shafts

### Superstructure

LED Rear lights

Service walkway with anti-slip grating

Centralised lubricating point for slew bearing

### Digging equipment

Attachment points for extra hydraulics

Centralised lubrication point

### Cab and interior

Volvo Care Cab with fixed roof hatch /ROPS

Heater & air-conditioner, automatic

Hydraulic dampening cab mounts

Adjustable operator seat and joystick control console

Adjustable steering column

Hydraulic safety lock lever

Control joystick, with 5 switches each

Cab, all-weather sound suppressed, includes:

Cup holder

Door locks

Safety glass, light tinted

Floor mat

Horn

Large storage area

Pull-up type front window

Removable lower windshield

Retractable seat belt

Windshield wiper with washer and intermittent feature

Sun shield, front, roof & rear

Master ignition key

## STANDARD EQUIPMENT

### Hydraulic system

Load sensing hydraulic system

Cylinder cushioning

Cylinder contamination seals

Return filter of full flow type 2 000 h exchange interval

Pressure relief system (servo accumulator)

Proportional controlled visco-clutch cooling fan

Hose rupture valve for boom

Hydraulic long life oil ISO VG46

## OPTIONAL EQUIPMENT

### Engine

Diesel coolant heater with digital timer

Block heater, 240 V

Water separator with heater

Dust net

Reversible fan

Tropical cooling

### Electric / Electronic control system

Travel alarm

Rotating beacon

Extra work lights:

Service walkway 1 and counterweight 1

Boom-mounted 2

Cab front 2

Multi-channel electric centre passage

Anti-theft system

Tilting and rotating attachment preparation

CareTrack via satellite

### Hydraulic system

Hose rupture valve for dipper arm

Boom float function

Hydraulic oil, biodegradable ISO VG32

Hydraulic oil, biodegradable ISO VG46

Hydraulic long life oil ISO VG32

Hydraulic long life oil ISO VG68

Hydraulic equipment for:

Hammer & shears

Slope bucket/rotator

Grab/clam shell

Quick fit

Flow control

Flow and pressure control

## OPTIONAL EQUIPMENT

### Cab and interior

- Volvo Care Cab with openable PC roof hatch / ROPS
- Tiltrotator Joystick
- Proportional control joystick
- On/off joystick
- Falling object guard (FOG)
- Cab mounted falling object protective structures (FOPS)
- Rain shield, front
- Side camera
- Sunlight protection, roof hatch (steel)
- Safety net for front window
- Lower wiper
- Anti-vandalism kit
- Radio with CD player and MP3 input
- Ashtray
- Lighter
- Seat:
  - Fabric seat, with heater
  - Fabric seat, with heater and air suspension

### Undercarriage

- Twin tires 10.00 - 20 / 11.00 - 20
- Single tires 18R - 19.5 / 620/40-22.5
- Stone protection rings
- Front dozer blade and rear outriggers
- Rear dozer blade
- Front outriggers and rear dozer blade
- 4 outriggers
- Grab holder
- Mudguards, front/rear
- Tool box, left hand side/right hand side
- Cruise control
- Travel speed EW210D: 20 km/h, 25 km/h, 30 km/h
- Travel speed EW180D: 20 km/h, 30 km/h, 35 km/h
- Wide axle 2.75 m

### Digging equipment

- Booms
  - EW180D: 5.2 m monoblock EW210D 5.6 monoblock
  - EW180D: 5.3 m 2-piece boom EW210D: 5.5 m 2-piece boom
- Dipper arms
  - EW180D, 2.45 m, 2.6 m, 3.0 m
  - EW210D, 2.45 m, 2.6 m, 2.9 m
- 3.2 m grab arm

### Hydraulic quick fit

- S1 system
- Universal system

### Attachments

- Buckets, direct fit and quick fit:
  - General Purpose bucket (GP)
  - Heavy Duty bucket
  - Slope bucket
- Lifting eye

### Service

- Tool kit, daily maintenance

### Superstructure

- Heavy counter weight only EW210D
- License plate preparation

Standard and optional equipment may vary by market.  
Please consult your local Volvo dealer for details.

## SELECTION OF VOLVO OPTIONAL EQUIPMENT

Boomfloat



Lifting eye



Elevated cab



Wide axles



Auto digging brake



Tilt rotator joysticks



# VOLVO CONSTRUCTION EQUIPMENT

Volvo Construction Equipment is different. Our machines are designed, built and supported in a different way. That difference comes from an engineering heritage of over 175 years. A heritage of thinking first about the people who actually use the machines. About how to help them be safer, more comfortable, more productive. About the environment we all share. The result of that thinking is a growing range of machines and a global support network dedicated to helping you do more. People around the world are proud to use Volvo.

Not all products are available in all markets. Under our policy of continuous improvement, we reserve the right to change specifications and design without prior notice. The illustrations do not necessarily show the standard version of the machine.

# **VOLVO**

**Volvo Construction Equipment**  
[www.volvoce.com](http://www.volvoce.com)

Ref. No 20030259-B  
2012.04  
Volvo, Global Marketing

English-21  
EXW