

WORKMAX



A Product of Hard Work





Tough, versatile, reliable

JCB WORKMAX are go-anywhere Utility Terrain Vehicles (UTVs) designed for the professional user; golf course management, gamekeeping, amenities, equestrian centres, leisure, forestry, events management, agriculture and construction. No matter what area you specialise in, these machines enable you to transport equipment, materials, livestock and people over fine turf or rough conditions. They can also be adapted for specific tasks, such as line marking, spraying and sweeping. Both the 1000 D and the 6x4 have high-torque powerful diesel engines.

REAL GO-ANYWHERE PERFORMANCE



Here's a choice in professional use Side-by-Sides you can rely on to keep performing, even in the toughest conditions. Both have high payloads, with the ability to carry 500kg (1102lbs) and tow 500kg at the same time. Plus they are easy to get from site to site, either on the road with travel speeds of up to 50kph (31mph – 1000 D) and 29kph (18mph – 6x4), or on the back of a trailer. The 6x4 with turf tyres is the best choice for surfaces that you don't want to damage, such as golf courses. The 1000 D is the machine to get you out of trouble on mud and steep inclines, thanks

to a powerful engine, increased torque, fully independent suspension, high ground clearance. Both machines also offer a range of options – from cabs, electric winches and road legal kits, to a choice of yellow or green – for your specific needs. It all makes these machines the tough, versatile and reliable choice for productive performance.

WORKMAX 1000 D

19.5kW (26hp) diesel engine delivers impressive torque for difficult ground conditions

Fully independent suspension at each wheel with rear variable rate springs gives impressive road holding and ride comfort even when carrying a full load

4x4 CVT features a high/low gear range and engine braking for easy driving and control

All-wheel hydraulic disc brakes with split circuit provide excellent stopping power

Top speed of 50kph (31mph) gets you around and between sites quickly



With a number of new developments and options, this 4x4 perfectly demonstrates JCB's commitment to answering the growing demand for utility terrain vehicles (UTVs) that offer increased versatility.

First, we have added a front hitch for attachments such as a snow blade or sweeper, opening up machine use for professional users throughout the seasons. In addition, a new full ROPS cab option gives extra protection from the elements.

Machine handling is improved with an electric power-assist steering option which adapts response to travel speed. When the 1000 D is driving at a very low speed, maximum assist makes steering light and easy, requiring 75% less effort than a non-power-steer machine: manoeuvring is made much easier in tight areas and operator fatigue is reduced. At 50kph maximum speed, power assist is significantly reduced to ensure positive feel and control.

Much of the versatility comes from its key role as a strong load-carrying machine. To develop this capability, we have focused on heavy-duty componentry, such as independent rear trailing arm suspension, the most substantial on the market. Meanwhile, the rear cargo deck features strong chequer-plate steel, hinged drop sides that are easily removed for carrying outsize loads and new rear fenders for improved protection.

Finally, this machine is built to tackle the toughest ground conditions, again enhancing versatility. Our unique design – no other UTV can boast the same - mounts the engine and drivetrain on its own steel 'skid unit' which, apart from being bolted to the main chassis through four vibration-reducing, resilient bushes, acts as a protective underbelly just like armourplate.

So take the example of steel or timber fence posts lying hidden, ready to rear up when disturbed and spear major components. The design, along with steel guards in front of the rubber steering boots, ensures this simply can't happen, protecting your versatile investment.





So many variations to suit every application

Tailoring service lets you adapt both machines for specific uses, from ambulance to military vehicle

Road legal specification lets you travel between job sites with no need for an additional vehicle or trailer

Electric winch provides 1.4 tonnes of line pull for added versatility

A choice of tyres lets you specify machines for the road, fine turf or rough/steep conditions

Additional options and attachments let you tailor your vehicle to specific applications



JCB WORKMAX UTVs are productive performers whatever your business. You can add a sprayer, a snow clearer, a line marker, have canopies fitted to the cargo deck for carrying animals, introduce lockable storage for tools and trailers, and so much more.

Available specified for road legal use, with kits including work lights, indicators, a fog light, reversing lights, horn, front and rear lights, plus a rear lighting board with space to attach a number plate. A road legal kit gives you the ability to travel between job sites with no need for an additional vehicle and trailer for applications where work takes place at several locations.

Both models also offer an electric winch option. This winch sits behind the front tool mount and produces 1.4 tonnes of line pull. It also has a handheld trigger for remote use and rollers to guide the cable ensuring a smooth feel.

For added protection against the elements, cab options are available. A full hard cab with front screen comes complete with washer and wipers, rear screen and glass doors. There is also a full soft cab with glass front screen, washer and wiper, and doors and rear screen which can be rolled up as and when required. The soft cab can be ordered without doors and also just with the cab frame and roof.

Additional options include hydraulic tipping cargo deck, electric tipping for the 6x4, load-bay strapping points, speedometer, ball hitch (with or without trailer socket) and a choice of tyres. The 6x4 also comes with the option of front nudgebar and front bumper with tool mount.



Camouflage option





Operator Environment

Ergonomic dash layout.

Adjustable driver's seat.

Cup holder, phone charger point and bonnet release catch as standard.

Closing glove box, storage space under passenger seat and under-bonnet area.

Familiar automotive style layout for foot pedals.

Anti-slip checker plate on floor for safety.

Optional hard or soft cab for increased operator comfort and weather protection.

Engine and Transmission

Powerful 19.5kW (26hp) engine.

Tier 3 compliant.

Easy to use CVT transmission with 2-speed gear box.

Selectable low or high range.

Selectable 4-wheel drive.

Selectable rear differential lock for additional traction.

Top speed of up to 50kph (31mph).

Tyres

Choice of Terratrac (road/turf), Polartrac (intermediate off road) or Bear Claw (off road) tyres, specific to your application.

Suspension

Fully independent 4-wheel suspension.

Macpherson strut on front with 203mm (8") travel.

Trailing arm on rear with 157mm (6.2") travel.

Variable-rate springs at rear for operator comfort laden or unladen.

Optional electronic power steering

Brakes

Disc brakes all round for effective braking.

4-hydraulic callipers with split circuit for stopping power.

Armoured brake hoses.

Twin rear callipers on handbrake for safe parking and emergency stopping.

Electrics

All vulnerable connectors to Standard IP69.

Road-legal light kits available.

Easy Service Access

Dipstick and air filter easily accessible under the cargo deck.

Coolant and brake fluid at the front of the under-bonnet storage area.

Fuel and oil filters under driver's seat.

Battery and fuses in footwell, behind driver's legs.

Cargo Deck

Strong 10-gauge steel cargo deck.

Checker plate on floor of cargo deck to prevent damage from loads.

Sides fold down and are removable as are the tailgate and corner posts.

Payload of 500kg regardless of terrain.

Hydraulic or manual tip available.

Chassis

One-piece structure.

Designed using FEA.

Front and underbody protection fitted as standard.

Strong and durable.

Safety

ROPS frame as standard.

Retractable seat belts as standard.

Grab handles on either side and on ROPS frame on passenger side.

Disc brakes all round with split circuit.

Fully independent suspension gives better handling on rough or smooth terrain (laden or unladen).

CARGO CAPACITY: 500kg (1102lb) ENGINE POWER: 19.5kW (26hp) MAX. TRAVEL SPEED: 50kph (31mph) (with Bear Claw tyres)

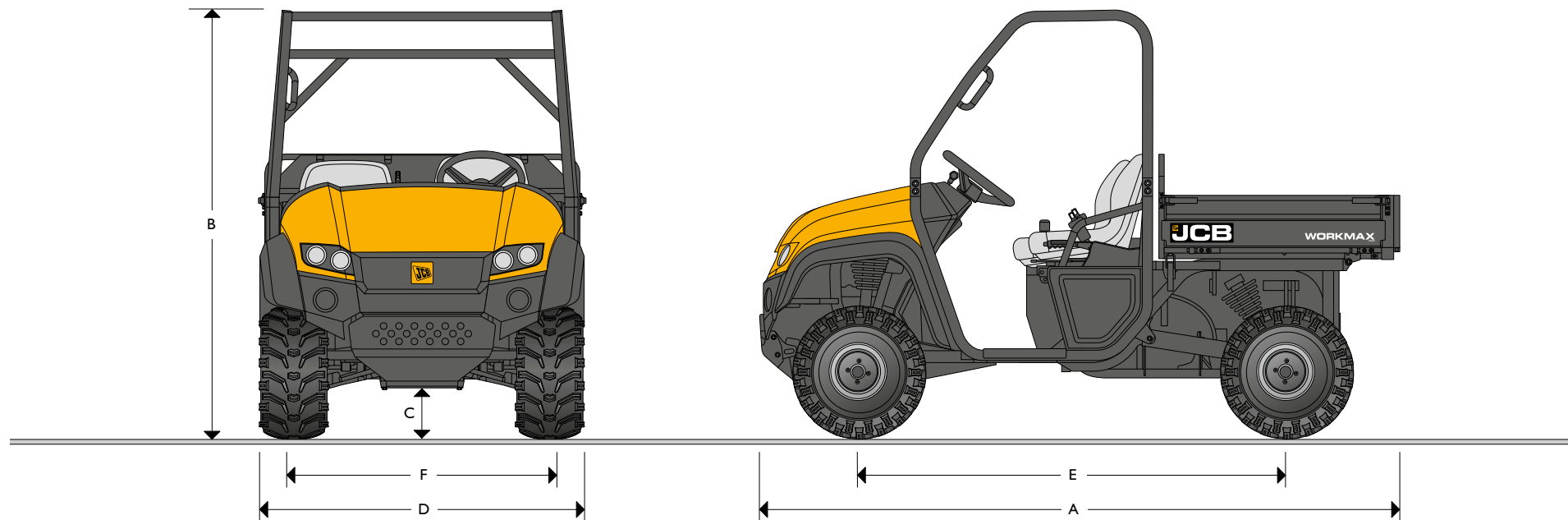

STATIC DIMENSIONS

Machine model	1000 D	Machine model	1000 D
	mm (ft-in)		
A Overall length	2914 (9-7)	Tipping angle	degrees 55
B Max. height (over ROPS)	1954 (6-5)	Cargo deck	
C Ground clearance	228 (0-9)	Length	mm (ft-in) 1046 (3-5)
D Overall width	1491 (4-11)	Width	mm (ft-in) 1384 (4-6)
E Wheel base	1950 (6-5)	Depth	mm (ft-in) 235 (0-9)
F Wheel track front and rear	1229 (4-0)	Capacity	kg (lb) 500 (1102)
		Volume	m ³ (ft ³) 1.34 (47)



ENGINE

Machine model		1000 D
Type		3 Cylinder Diesel
Capacity	litres (in ³)	1.028 (62.7)
Bore	mm (in)	75 (2.9)
Stroke	mm (in)	77.6 (3.0)
Aspiration		Natural
Cylinders		3
Rated power – ISO 14396 (SAE J1995 – Gross)		
Gross power	kW (hp)	19.5 (26)
Torque rating		
Gross torque	Nm (lbf-ft)	60.5 (44.62)

Exhaust emissions certified to EU NRMM 97/68/EC Stage 3A EPA Tier III.

TRANSMISSION

Machine model		1000 D
Type		Continuously Variable Transmission (CVT)
Gear selection		High/Low/Reverse/Neutral
Differential lock		Rear hand selectable
4 wheel drive		Selectable
Road speed		0 to 50kph (0 to 31mph) (with Bear Claw tyres)

TYRES

Machine model		1000 D
Terratrak (Turf/Road), Polartrak (Intermediate off road)		
Front		23 x 10.50-12
Rear		23 x 10.50-12
Bear Claw (Off road)		
Front		25 x 10-12
Rear		25 x 10-12

SERVICE FILL CAPACITIES

Machine model		1000 D
Fuel tank	litres (gal)	39 (8.6)
Engine oil sump & filter (max.)	litres (gal)	2.6 (0.6)
Transmission system – Gearbox	litres (gal)	1.2 (0.3)
Transmission system – Front diff	litres (gal)	1.0 (0.2)
Transmission system – Rear diff	litres (gal)	1.0 (0.2)
Engine coolant system	litres (gal)	4.0 (0.9)

SUSPENSION

Front: Independent Macpherson strut. **Rear:** Independent with trailing arm and variable rate springs.

BRAKES

Service: Dual circuit hydraulic system with discs all round. **Park brake:** Lever with cable operation on rear callipers.

ELECTRICAL SYSTEM

Machine model		1000 D
System voltage	volt	12
Alternator output	Amp hour	50
Battery capacity	Amp hour	60

OPERATOR ENVIRONMENT

Fully adjustable drivers seat, with fixed passenger seat. Glove box and storage space under passenger seat and bonnet. Side grab handles and also on ROPS frame passenger side. Good all round visibility. ROPS frame as standard.

TURNING CIRCLE

Clearance radius 7440mm (24ft 5in)

OPERATING WEIGHTS

Machine model		1000 D
Unladen weight (including fuel and fluids and ROPS frame)	kg (lb)	850 (1875)
Maximum payload (including 2 operators at 100kg each)	kg (lb)	700 (1543)
Towing capacity (Unbraked)	kg (lb)	500 (1102)

STANDARD EQUIPMENT

Engine: Tier III compliant.

Steering: Rack and pinion with a turning clearance circle of 7440mm (24ft 5in).

Body: Steel front and underbody protection.

Cargo Deck: 10 gauge floor plate steel load bay with fold-down and removable sides.

Electrics: Basic front lights.

ROPS frame.

OPTIONAL EQUIPMENT

ROPS mounted canopy. Hydraulic tip. Roadlights. Worklights. Front winch. Front tool mount. Trailer electrics and hitch. Rear towball. Hard or soft sided cab. 4 Land strapping points. Speedometer. Beacon kit. Option of black seats. Front screen with washer and wiper. Rear screen. Road legal kit. Front bullbar. Battery charger. Alternator cover. Rear fenders includes and flaps. Power steering. Additional tyre sets.





WORKMAX 6x4

15.6kW (20.9hp) diesel engine powers 6x4 wheel configuration with permanent 4WD

Automotive layout with plenty of legroom provides comfort and ease of operation

CVT transmission with manual differential lock offers uninterrupted acceleration and deceleration

High-flotation tyres equal low ground bearing pressure and good traction

500kg (1102lbs) steel tipping cargo box (hydraulic or electric optional) gives high capacity



At the heart of the 6x4 is a 768cc, liquid-cooled, 15.6kW (20.9hp) engine which powers a 6x4 wheel configuration with permanent four-wheel drive. Allied to a superior power-to-weight ratio this gives the 6x4 extra performance in difficult ground conditions and on inclines. Plus the machine can be specified with a choice of turf tyres, for minimum ground damage, or rough terrain tyres, for dependable traction on heavy ground.

With its low ground bearing pressure and a top speed of 27kph (18mph), the main use is transporting loads and people across fine turf, such as golf courses, and on estate roads. For a more stable and comfortable ride there's a long wheel base, while the continuously variable transmission gives you uninterrupted acceleration and deceleration for a smooth ride. The transmission also features a Kevlar drive belt for added durability.

The 6x4 has a high-capacity tipping cargo deck with a payload of 500kg (1102lbs) and it can tow 500kg at the same time, allowing you to transport all the equipment and materials you need.

The 6x4 is built to last, with a strong, rugged construction and 16-gauge steel deck. The large 60A alternator minimises wear on the battery, extending battery life and enhancing overall reliability, while a superior fuel filtration system separates out both dirt and water for more efficient running. The machine is also easy and quick to maintain, with all routine checks simple to perform and the tipping steel cargo deck providing ample service access.







Operator Environment

Spacious operator area with good leg room, adjustable driver's seat and cup holders.

Familiar automotive style layout for footpedals.

Ergonomic dash layout.

Optional hard or soft cab for increased operator comfort and weather protection.

Engine, Transmission and Braking

Powerful 15.6 kW (20.9hp) Perkins engine.

Excellent power-to-weight ratio.

CVT transmission gives speed of 29kph (18mph).

Continuous 4-wheel drive.

Transmission belt is Kevlar reinforced for long life.

Enclosed wet disc brakes to prevent damage and ingress of dirt.

Tyres

Choice of Turf, Dirt Dog (chevron), Scorpion (knobbly) or Bear Claw (off road) tyres, specific to your application.

Steering and Suspension

Rack and pinion steering with 8500mm (27ft 11in) turning circle.

Independent front suspension with single swing arm and coil over shock absorber.

Fixed rear wheels.

Service Access

Dipstick, coolant, air, oil and fuel filters all grouped easily together under the cargo deck.

Fuses kept dry but easy to access under the driver's seat.

Chains transmitting drive to rear wheels easily accessible for greasing by lifting the cargo deck.

Electrics

All vulnerable connectors to Standard IP69

Road legal light kits available.

Cargo Deck

Strong steel cargo deck.

Choice of hydraulic, electric or manual tipping.

Payload of 500kg (1102lbs) regardless of terrain.

Optional load strapping points to keep load secure.

Optional cargo deck liner.

Chassis

Durable and strong.

One-piece structure.

Bottom of chassis enclosed to prevent damage to components by rocks and debris.

Optional front bumper.

Safety

Solid side panel with grab handle for driver and passenger safety.

Optional ROPS frame with retractable seat belts.

CARGO CAPACITY: 500kg (1102lb) ENGINE POWER: 15.3kW (20.5hp) MAX. TRAVEL SPEED: 29kph (18mph)

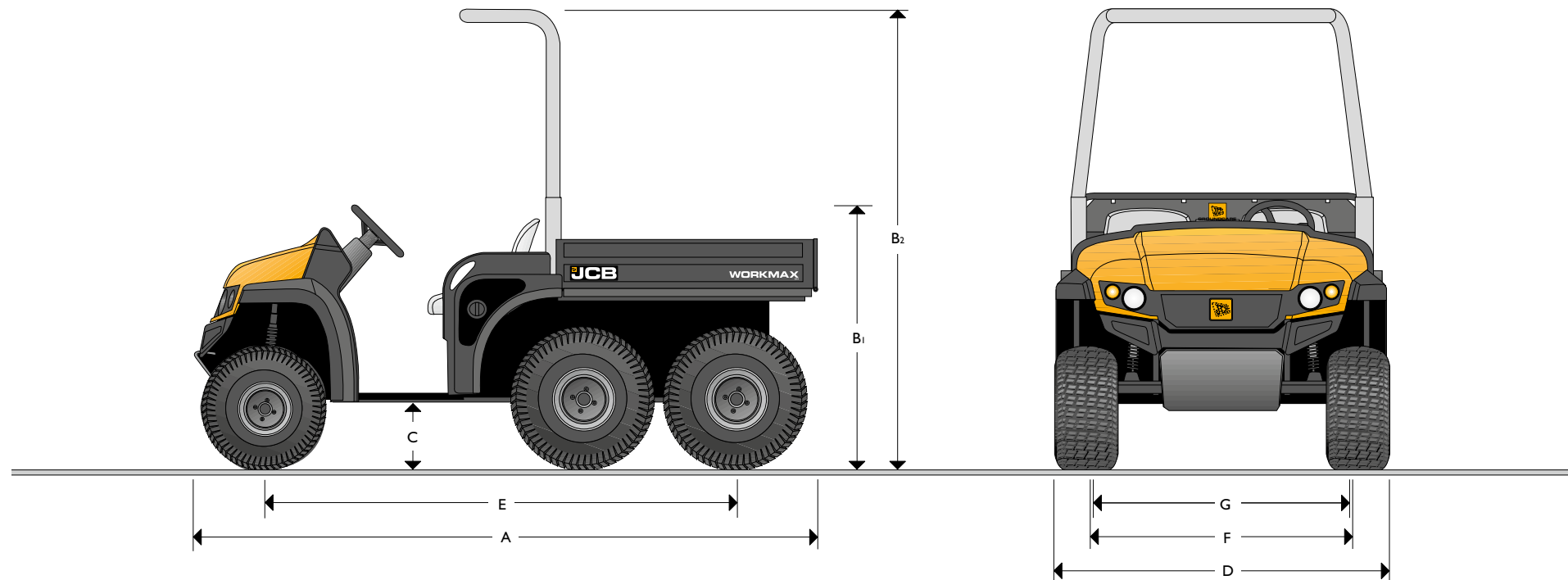

STATIC DIMENSIONS

Machine model	WORKMAX 6x4
	mm (ft-in)
A Overall length	2800 (9-2)
B ₁ Max. height	1179 (3-10)
B ₂ Max. height (with ROPS)	1963 (6-5)
B ₂ Max. height (with hard cab)	1963 (6-5)
C Ground clearance	196 (0-8)
D Overall width	1610 (5-3)
D Overall width (with hard cab)	1610 (5-3)
E Wheel base	2078 (6-10)
F Wheel track front	1265 (4-2)
G Wheel track rear	1210 (3-7)

Machine model		WORKMAX 6x4
Tipping angle	degrees	53
Cargo deck		
Length	mm (ft-in)	1124 (3-8)
Width	mm (ft-in)	1280 (4-2)
Depth	mm (ft-in)	220 (0-9)
Capacity	kg (lb)	500 (1102)
Volume	m ³ (ft ³)	0.32 (11.3)



ENGINE

Machine model		WORKMAX 6x4
Type		3 Cylinder Diesel
Capacity	litres (in ³)	0.768 (46.5)
Bore	mm (in)	67 (2.6)
Stroke	mm (in)	72 (2.8)
Aspiration		Natural
Cylinders		3
Rated power – ISO 14396 (SAE J1995 – Gross)		
Gross power	kW (hp)	15.6 (20.9)
Torque rating		
Gross torque	Nm (lb-ft)	50 (37)

Exhaust emissions certified to 97/68/EC Stage II.

TRANSMISSION

Machine model		WORKMAX 6x4
Type		Continuously Variable Transmission (CVT)
Gear selection		Forward/Reverse/Neutral
Differential lock		Hand operated as standard
Main drive through a kevlar drive belt for extended life		
Road speed		0 to 29kph (0 to 18mph)

TYRES

Machine model		WORKMAX 6x4
Turf, Dirt Dog (Chevron), Scorpion (Knobbly), Bear Claw (Off road)		
Front – 2		22.5 x 10-8
Rear – 4		25 x 12-9

SERVICE FILL CAPACITIES

Machine model		WORKMAX 6x4
Fuel tank	litres (gal)	20 (4.4)
Engine oil sump & filter (max.)	litres (gal)	3.05 (0.7)
Transmission system	litres (gal)	4.5 (1.0)
Engine coolant system	litres (gal)	3.5 (0.8)

SUSPENSION

Front: Independent spring over single arm swing shock.

Rear: 4 high-flotation, low pressure tyres.

BRAKES

Service: Internal wet disc. **Park brake:** Hand operated.

ELECTRICAL SYSTEM

Machine model		WORKMAX 6x4
System voltage	volt	12
Alternator output	Amp hour	60
Battery capacity	Amp hour	20

OPERATOR ENVIRONMENT

Fully adjustable drivers seat, with fixed passenger seat. Open storage compartment with twin cup holder space. Easily accessible with spacious leg room, with side hand rails and protection. Good all round visibility. Optional ROPS structure with seatbelts.

TURNING CIRCLE

Clearance radius 8500mm (27ft 10in)

OPERATING WEIGHTS

Machine model		WORKMAX 6x4
Unladen weight (including fuel and fluids – no ROPS)	kg (lb)	630 (1388)
Unladen weight (including fuel and fluids and ROPS)	kg (lb)	665 (1466)
Maximum payload (including 2 operators at 100kg each)	kg (lb)	700 (1543)
Towing capacity (Unbraked)	kg (lb)	500 (1102)

STANDARD EQUIPMENT

Engine: Tier III compliant.

Steering: Rack and pinion with a turning clearance circle of 8500mm (27ft 10in).

Body: Adjustable drivers seat. Operator storage facilities.

Cargo Deck: 16 gauge steel load bay.

Electrics: Basic kit featuring front lights with horn.

OPTIONAL EQUIPMENT

Worklight kit with front lights, horn and ROPS mounted worklights. Road light kit with front light, horn, worklights, indicators, fog light, reverse light and alarm and 12v power socket located at the front. Optional beacon and trailer socket and ball. ROPS frame (ISO 3471 and EN 13510) safety structure. Soft sided cab. Electric hoist. Hydraulic hoist. Nudge bar. Front towball.

A few words about JCB

A groundbreaking, world class family business with a commitment to supporting our customers and protecting the environment



A family company on a global scale. JCB is no ordinary company. From the dreams of one man, Joseph Cyril Bamford, we have grown into the world's largest privately owned construction equipment company. Since 1945, the same attention to detail, passion for progress and family spirit has taken us from strength to strength.

Nowadays JCB operates across five continents, manufacturing at 18 factories in the UK, Brazil, Germany, China, North America and India. With 1,500 dealer depots selling and supporting our products in over 150 countries, we are the global market leader for backhoe loaders and telescopic handlers.

A history of world-class innovation. Our business has always been driven by innovation, using only the most advanced technology, meticulous design, precision engineering and rigorous testing. Evidence of this commitment to innovation is illustrated in our revolutionary JCB Dieselmix engine. Having grabbed the headlines when it smashed the world diesel land speed record at 350.092mph, it is now providing our customers with tomorrow's performance today.



Doing things more efficiently, more sustainably. Since 2007 we have reduced our carbon emissions by 20%. We are continually working to further reduce the carbon footprint of our operations and, in partnership with our suppliers, our whole supply chain. We are also committed to designing our products to be sustainable during manufacturing, over the life of the machine and through end-of-life recycling. Our new Eco machines, for example, offer significant fuel and carbon savings; an average of 16% on the Eco backhoes and 22% on the 8085 Eco.





The best back-up in the business

Whether we're providing you with support, parts or finance, we aim for 100% satisfaction. It's all part of our promise to put you, the customer, first

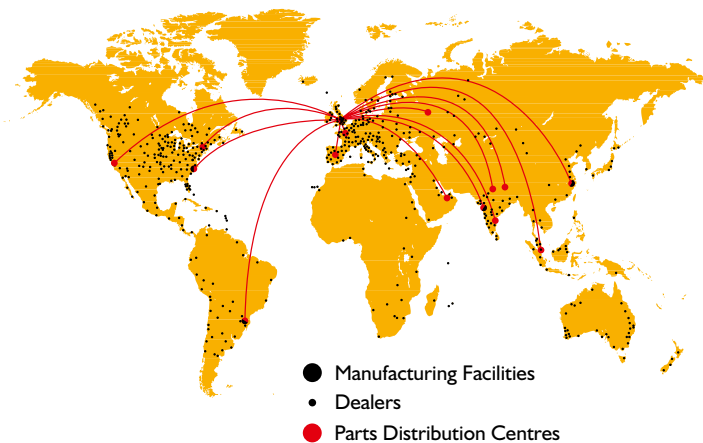

Wherever you are, we are. Our mission to provide world-class support and deliver 100% satisfaction reaches into more than 1,500 dealer depots, spanning 150 countries across five continents. The aim? To bring you global expertise at a local level. We truly believe no other manufacturer does more to understand the subtle differences between one region of the world and another. It's a degree of attention that we maintain at every level of the company and an assurance to our customers that wherever they are in the world, JCB will fulfil their needs.

Trust the genuine article. At the heart of the support network is our impressive World Parts Centre, a state-of-the-art facility operating 24/7 to dispatch more than a million genuine parts and attachments every week to our dealers and international distribution centres. Because we understand the need to minimise downtime, we utilise the latest logistics and warehouse management systems and have committed to an 'Anywhere in 24 hours' strategy.

Keeping you up and running. Just as important as genuine JCB parts are the people who fit and maintain them. Our JCB-trained technicians in all of those 1,500-plus dealer depots provide excellent, expert customer care, whether it's routine servicing or something more urgent. If there is an emergency breakdown situation, we need to act fast. This is why all our dealers operate their own fleets of support vehicles, enabling parts to be delivered quickly and fitted expertly, and fulfilling our promise to keep our customers working.

Maximising earning potential. We grow as our customers grow. That's why, at JCB, we are committed to offering expert financial advice and support to help customers maximise their earning potential.

Finance options* are available for new and used machinery, all part of our dedication to helping customers preserve their working capital while spreading costs in the most effective and tax-efficient way.

And as well as financial help, we are also happy to offer JCB Insurance.* We specialise in construction and industrial insurance and in offering Insurance Premium Finance facilities.

** Please check individual countries for available services.*



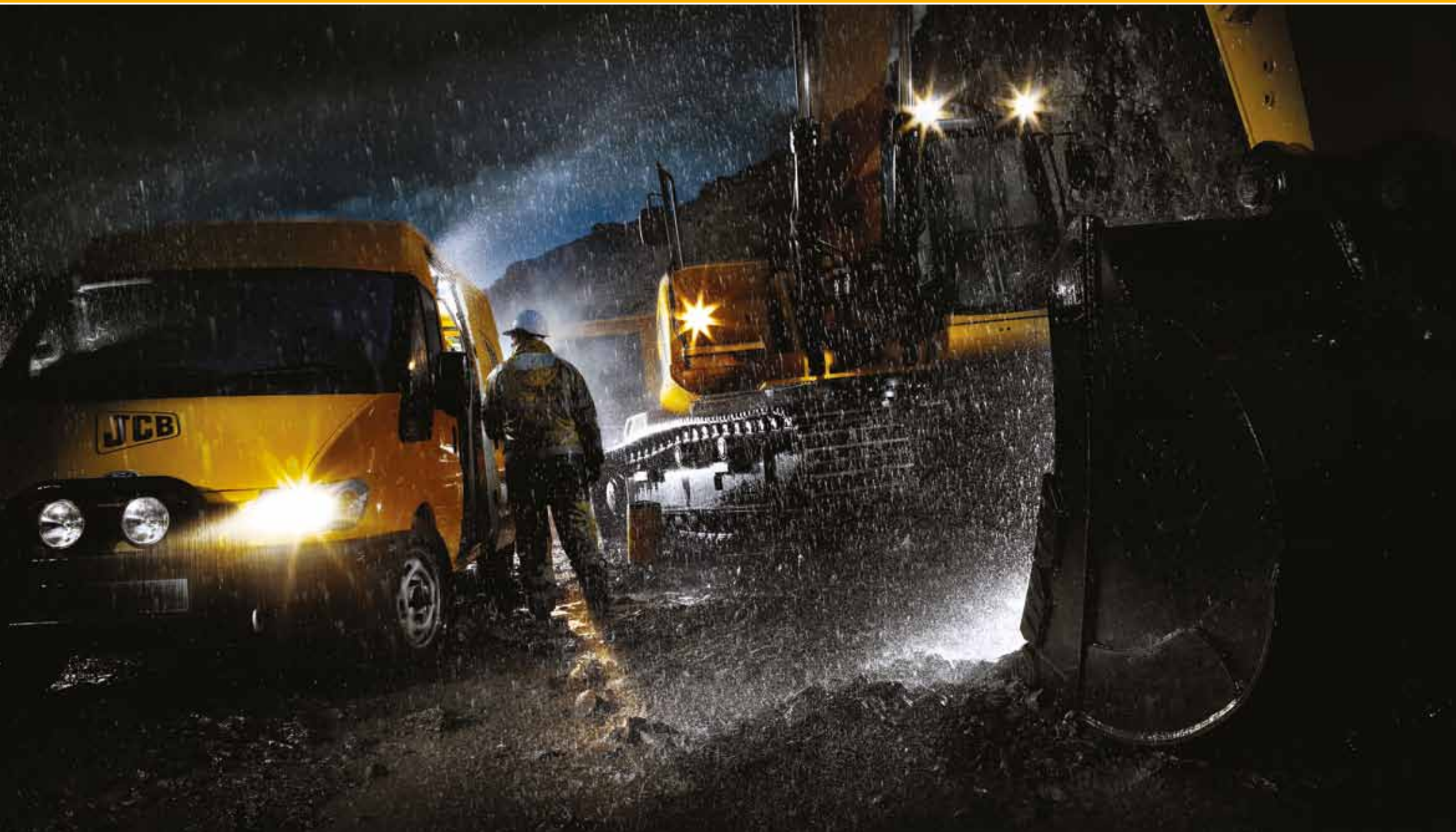



JCB Utility Products, Cecilly Mills, Oakamoor Road, Cheadle, Staffordshire, United Kingdom ST10 4QT. Tel: +44 (0)1538 758000 Email: salesinfo@jcb.com
Download the very latest information on this product range at: www.jcb.com

©2009 JCB Sales. All rights reserved. No part of this publication may be reproduced, stored in a retrieval system, or transmitted in any form or by any other means, electronic, mechanical, photocopying or otherwise, without prior permission from JCB Sales.
JCB reserves the right to change specifications without notice. Illustrations and specifications shown may include optional equipment and accessories. The JCB logo is a registered trademark of J C Bamford Excavators Ltd.