

* | 375 HP (276 kW) - 500 HP (368 kW) at 2100 rpm - Stage IIIB (Tier 4i)

🏠 | 31 sh tn (28000 kg) - 44 sh tn (40000 kg)

🏠 | 23.5 yd³ (18 m³) - 31.9 yd³ (24.4 m³)



DA30 - DA40

Articulated Dump Truck



Preliminary



New generation of Doosan Articulated Dump Trucks

■ Reliable machinery for challenging conditions

Doosan strives to be a pioneer in the field of product development and performance.

With the new generation of DOOSAN Articulated Dump Trucks, the product features have been refined and innovated to meet the tough demands of the future. Our philosophy is to stay one step ahead of the competition and always deliver a full range of Articulated Dump Trucks to suit the market.



Doosan ADTs

Our goal has been to develop a new line of advanced, reliable and cost effective Articulated Dump Trucks, loaded with significant competitive advantages.

Thanks to a new, modern design and state-of-the-art technical features, Doosan ADTs offer you all the benefits you expect from an Articulated Dump Truck:

Power

Productivity

Stability

Traction

Reliability

Comfort

Scandinavian durability with Korean excellence

■ Aiming at the best

During the design phase of our new ADTs, the quality standards were further enhanced by Doosan expertise and reliable processes, creating best-in-class Articulated Dump Trucks that will give you complete satisfaction in all terrain conditions.

Thanks to more of thirty years dedicated to product development, the new generation of Doosan trucks provides innovative drivetrain and fatigue-proof structures.



The Doosan network is your best support

Thanks to the Doosan dealer support network and its fully owned parts distribution centers, we can provide parts distribution worldwide.

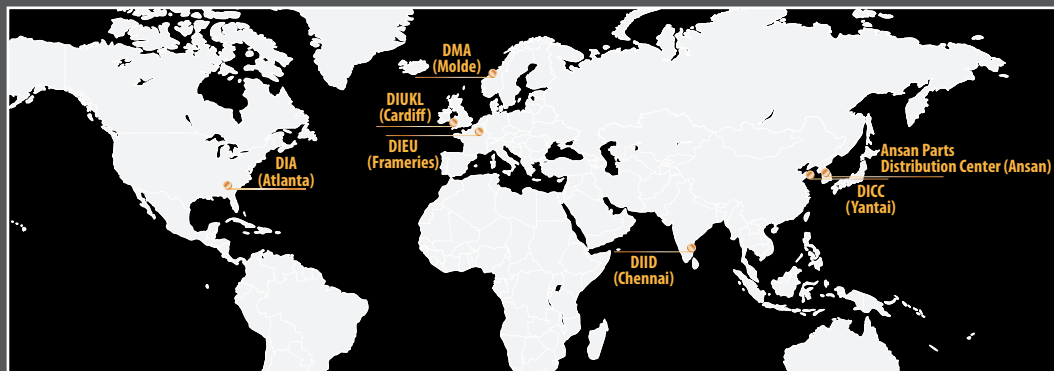

New productivity standards



PRODUCTIVITY

Exclusive transmission

The Doosan ADTs use reliable transmissions that feature smooth and equal gear shifting abilities. As a result, there is a maximum transfer of net power from the transmission to all 6 wheels, providing maximum traction and best-in-class fuel efficiency.

Downhill speed modulation

Downhill braking can be increased or decreased simply by "dosing" the accelerator pedal.

Convenient dump lever

A new fingertip-controlled body hoist/dump lever is conveniently located next to the gear lever. This location allows the operator to have full control over body hoisting and dumping with little strain to the wrist or arm. The floating feature on the body down function ensures a smooth, jolt-free lowering of the body to the rest position.

Engine



- DA 30**
 - Scania DC9
 - Power rating: (ISO 3046) 375 HP (276 kW)
(ISO 9249) 365 HP (268 kW)
 - No. of cylinders: 5 (in line)
 - Displacement: 9.3 litres
 - Air filter: Dry type



- DA 40**
 - Scania DC13
 - Power rating: (ISO 3046) 500 HP (368 kW)
(ISO 9249) 490 HP (360 kW)
 - No. of cylinders: 6 (in line)
 - Displacement: 12.7 litres
 - Air filter: Dry type



POWER

The Doosan ADT concept offers a larger load capacity in all weight categories. Additional load capacity, combined with superior power and traction, allow for improved productivity. The unique advantages of the Doosan ADTs permanent six-wheel drive, the free swinging rear tandem, the front mounted turning ring, the independent front wheel suspension and the sloping rear frame provide excellent driving stability with equal weight distribution and superior traction. The Doosan Articulated Dump Truck is designed to work under very tough conditions and travel over 55 km/h.

New engines – lower emissions / higher torque

Doosan ADTs use only proven, reliable and powerful diesel engines with excellent torque which achieve low fuel consumption and fulfil Stage IIIB (Tier 4i) European regulation requirements.

Total cost of ownership

By combining the newest Scania engines, ZF transmissions and our unique free swinging tandem drive, the running cost in terms of cost per tonne transported, is unrivalled in the market. Minimum fuel consumption is achieved whilst the lock up clutch is immediately engaged, avoiding any slippage and therefore loss of power.

Safe in all conditions



STABILITY

Bogie suspension

Doosan ADTs free-swinging rear tandem bogie and the special articulation system offer excellent performance and the best possible ground contact in soft and uneven terrain.

Rear frame

Thanks to the sloping rear frame, the load of the truck is distributed equally among the 6 tyres. This ensures a lower centre of gravity, greater stability, better tractive effort and less tyre wear, unlike our competitors.

Unique front wheel concept

One of the main highlights of the Doosan ADT design is the location of the turning ring in relation to the articulation point, which always ensures equal weight distribution to the front wheels.

Equal weight distribution to the front wheels makes it possible to use the differential locks while maintaining manoeuvrability.

Our unique independent front wheel suspension allows for maximum ground contact and shock absorption.

SAFETY

Thanks to the unique design of the forward-mounted turning ring, sloping rear frame and free swinging tandem bogie, weight is distributed equally throughout the truck, providing excellent stability. The rear tandem ensures the tyres are in continuous contact with the ground for more stability and thus the best safety in the market.

“Over Centre of Gravity” safety feature

During tipping of the body, this feature prevents a “sticky” load from lifting the front half of the truck. The system slows down the tipping speed when the load starts to pull the hoist cylinders backwards.

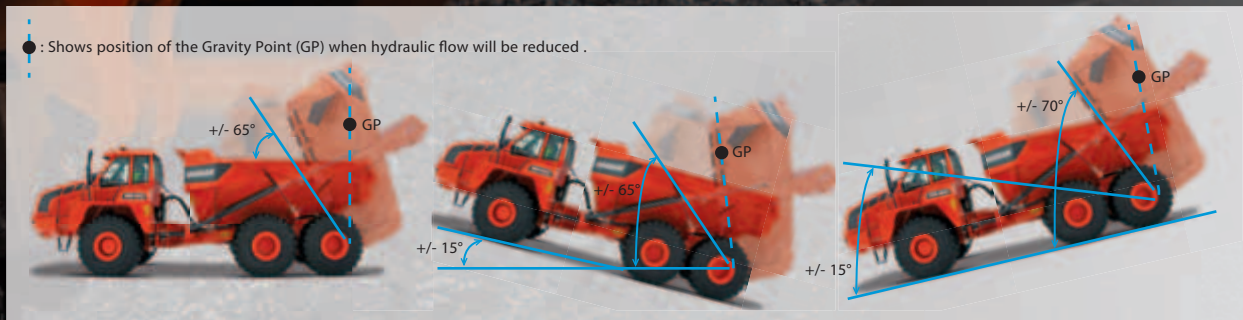

Rear view camera

Offers a clear view of what's happening behind the machine for maximum safety and peace of mind.



TRACTION

The unique Doosan ADT design offers permanent six-wheel drive which ensures stability and equal weight distribution to accommodate all job applications.

The Doosan ADTs superior driveline ensures maximum traction and durability.

Semi-independent front suspension

New hydro-pneumatic system specially designed for our big trucks.

Low ground-bearing pressure

Thanks to the combination of the sloping rear frame for better weight distribution and the free swinging tandem, the ground bearing pressure of our ADTs is equal to that of a traditional machine equipped with flotation tyres.

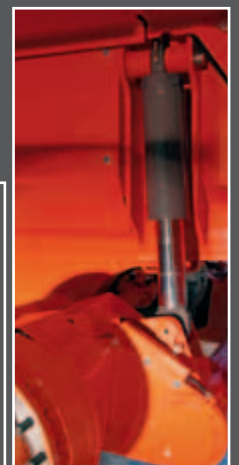
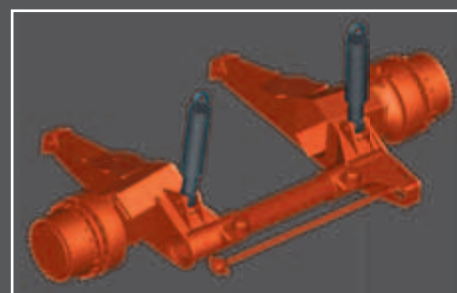



Climate control

Hot / cool box

Air suspension seat

Tilttable and telescopic steering



OPERATE IN COMFORT & SIMPLICITY

- The ROPS/FOPS cab is equipped with climate control and an high quality operator seat with air suspension to provide excellent comfort. Precise steering, good visibility and low noise levels [73 dB(A)] provide a comfortable cab environment
- The sloping hood provides an excellent view from the operator's position
- The cab is mounted on a special rubber suspension in order to reduce vibration and noise transfer into the cab

Best-in-class operator environment

Doosan ADTs are powered by industry-leading engines that achieve low fuel consumption and meet the latest Stage IIIB European regulations in addition to all noise regulations. Doosan ADTs provide exceptional operator comfort with low cab vibration and noise levels.



When operating becomes easy



CONTROLLABILITY

Body hoist lever

The new body hoist lever is easy to operate and fingertip controlled. This electronically managed hoist lever incorporates a higher body up speed and an automatic body down feature with soft touch down, allowing you to work in safe conditions.

"Tip-tronic" gearshift

This feature enables the operator to run the truck in both automatic and manual gears to ensure the smoothest possible gear shifts and momentum while operating the truck.

Excellent all-round visibility

Thanks to the excellent position and the use of special "wide angle" (heated) side mirrors, the operator is assured of having excellent all-round visibility for safer operation.

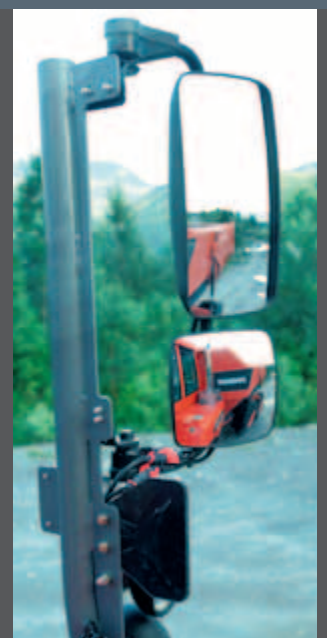



LCD colour monitor panel

- 7" colour display, resolution 800 x 480 pixels
- Shows all necessary information for driving and handling the machine
- Embedded rear view camera image in instrumentation graphics
- Backlight dimming according to ambient light conditions
- Sub menus for additional and diagnostic functions



Touch pad

- Reduced retarder force (affects both retarder and engine exhaust brake)
- Diesel fuel heater ON/OFF
- Interaxle differential lock
- Override button
- Heated seat ON/OFF
- Cab roof and mirror arm front lights ON/OFF
- Rotating beacon ON/OFF

Reliability to maximise uptime



Built in-house using highly reliable components

Doosan ADTs are among the most reliable dump trucks in the industry thanks to the long history of using proven first-class components and manufacturing procedures.

With in-house control of all machining and robotic welding, Doosan is able to maximise the quality of all its assemblies.

Doosan ADTs use proven, specifically designed engine and transmission components tested not only by our suppliers, but also by rigorous "Doosan Reliability Growth" processes.

Turning ring

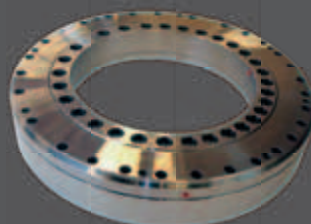

Axles



Maintenance and serviceability is a breeze



Excellent Service Accessibility

- The hood has a wide opening (up to 83°) to provide accessibility to the engine for easy maintenance
- The tilting cab allows the same clear access to the transmission and hydraulic components
- All electrical and AC connections are at the rear of the cab. This allows tilting of the cabin without disconnecting.
- The factory-fitted automatic central lubrication system is fully incorporated in the design of our ADTs. Thanks to the Vehicle Control Unit (VCU), the grease is only pumped when necessary.

Easy maintenance



Automatic lubrication system



Zooming in on Doosan ADTs - Turning ring

Forward mounted turning ring

One of the main innovative features in the Doosan ADT design is the location of the turning ring in relation to the articulation point. The turning ring is located in front of the articulation point, ensuring equal weight distribution to the front wheels in all operating situations, including during maximum turning. Equal weight distribution to the front wheels makes it possible to use the differential with only 45% locking value. This ensures drive to both front wheels in all situations without completely locking up the wheels. With many of our competitors, the turning ring is located behind the point of articulation, resulting in an unequal weight distribution to the front wheels. The combination of unequal weight distribution to the front wheels and the use of a 100% differential lock can cause steering difficulties and also result in higher stress on the driveline and increased, uneven tyre wear.

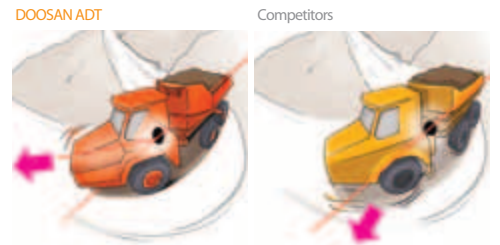

Weight distribution at the point of articulation

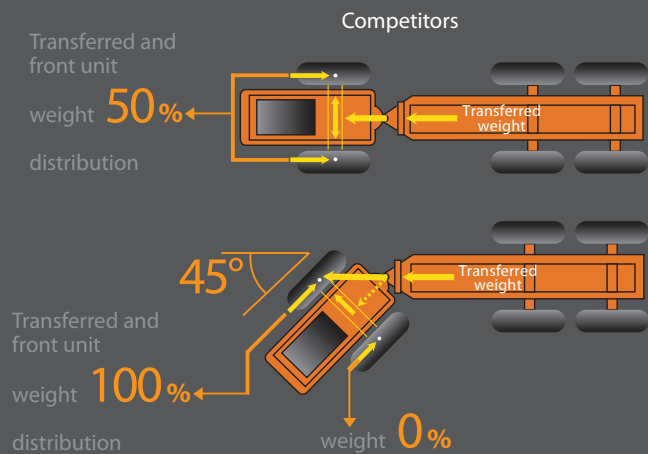
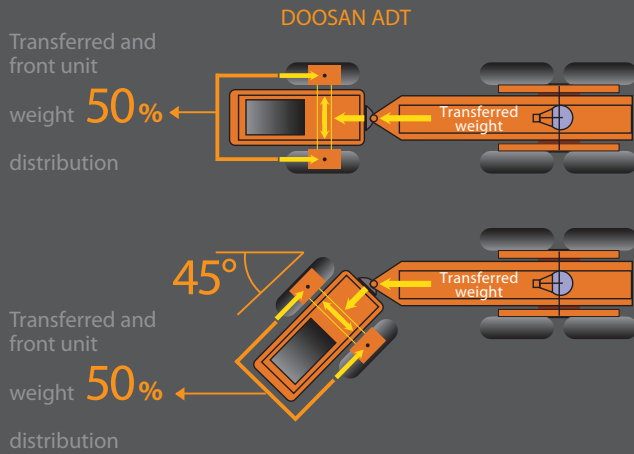

Unique sloping frame for improved weight distribution

The frame design of Doosan ADTs is similar to that used by manufacturers of rigid frame dump trucks. The frame is sloped downward from the hinge points to provide equal weight distribution on all axles when the truck is fully loaded. As a result, a lower centre of gravity is obtained, giving better stability.



Scania DC9
9.3 litres - 5 cylinders

Scania DC13
12.7 litres - 6 cylinders

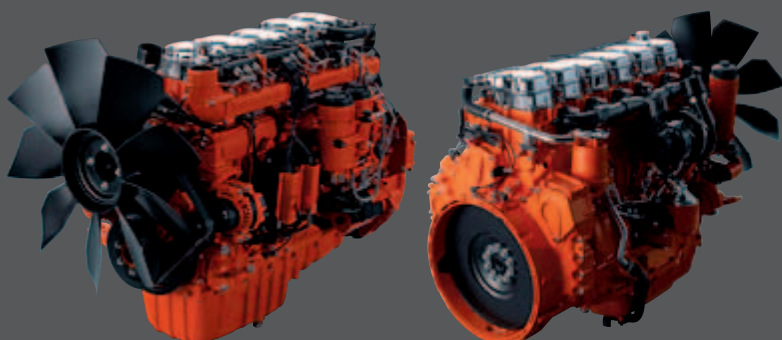

Selective catalytic reduction (SCR)

- Suitable for machines requiring high torque or speed such as the wheel loaders above 130 kW and articulated dump trucks
- Lower CO² emissions and better fuel efficiency
- Improved power, torque and acceleration
- No particle filter
- Can manage a higher sulphur level in fuel
- The addition of AdBlue® turns the exhaust into nitrogen and water which are environmentally safe
- Longer service intervals

SCR

Zooming in on Doosan ADTs – Driveline

Significantly reduced tyre wear

The single driveline requires the use of only one longitudinal differential lock to have an optimal power split of 50% to the front and 50% to the rear drive train. Combined with the use of only 2 state-of-the-art limited slip differentials, Doosan ADTs will always deliver best-in-class traction. One easy-to-lock differential is used in the rear, ensuring the best drive comfort. By contrast, our competitors use 2 rear differentials connected by an interaxle drive-through system which is subject to damage from the outside, loss of power and premature wear.

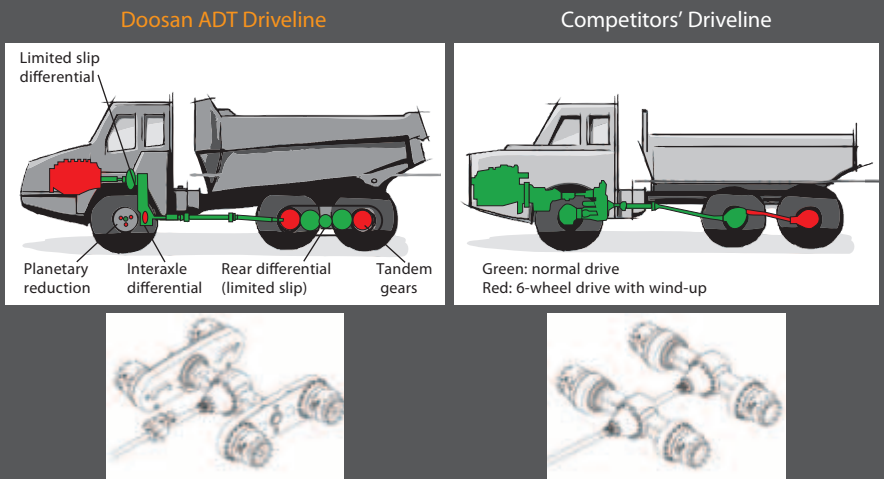

Free-swinging tandem bogie

The unique tandem drive ensures maximum productivity and allows easy loading of the truck in almost all positions and applications. Our competitors use rigid axles which cause movement on the centre or rear axle, resulting in loss of traction and driver discomfort.

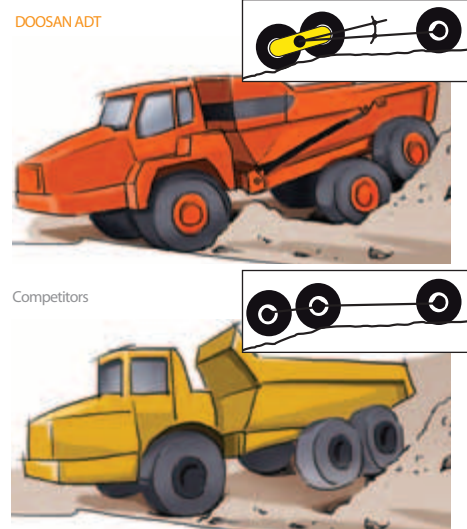

Continuous contact with the ground

The tandem bogie enables the wheels to be in continuous contact with the ground for better tractive effort, stability and safety. As there is only one differential, the driveline is more efficient with less loss of power and reduced wear of parts.

Front wheel suspension

The unique independent front suspension allows free movement of one side, ensuring maximum contact with the ground and excellent shock absorption.

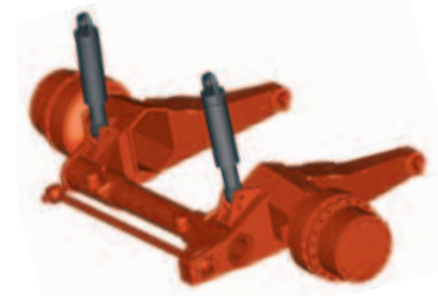

Wet disc brake on all 6 wheels

The oil-cooled wet disc brakes on the DA40 provide high braking performance and excellent durability. Dry disc brakes are open and exposed to dirt and water. Wet brakes are not affected by these conditions because they are fully encased in oil. With less servicing intervals, wet disc brakes last longer and are especially advantageous in very adverse conditions such as in deep mud and water.



The air-cooled disc brakes on the DA30 do not require forced cooling like most competitors.



Transmission

Unique Doosan ADT design – Front-mounted differential

Since the differential is mounted directly on the transmission, the total length of the truck is reduced. This design results in better weight distribution and a smaller turning circle, an important advantage in confined areas.

EP400 transmission range

The latest ZF transmission is designed specifically for Doosan ADTs.



Unique design of Doosan ADTs

DOOSAN Articulated Dump Trucks have permanent 6-wheel drive for equal power distribution while the free-swinging rear tandem bogie and the special articulation system offer excellent driving performance. The articulation hinge is positioned behind the turning ring to ensure equal weight distribution. The sloping rear frame provides a lower centre of gravity and improves the overall stability of the truck, ensuring fast and easy tipping of the body for increased productivity in even the most demanding conditions.

Many DOOSAN articulated dump trucks have worked more than 25,000 hours without a major overhaul of the engine. A fully automatic transmission and smooth gear-shifting provide maximum convenience and comfort, allowing the operator to concentrate on the work at hand.

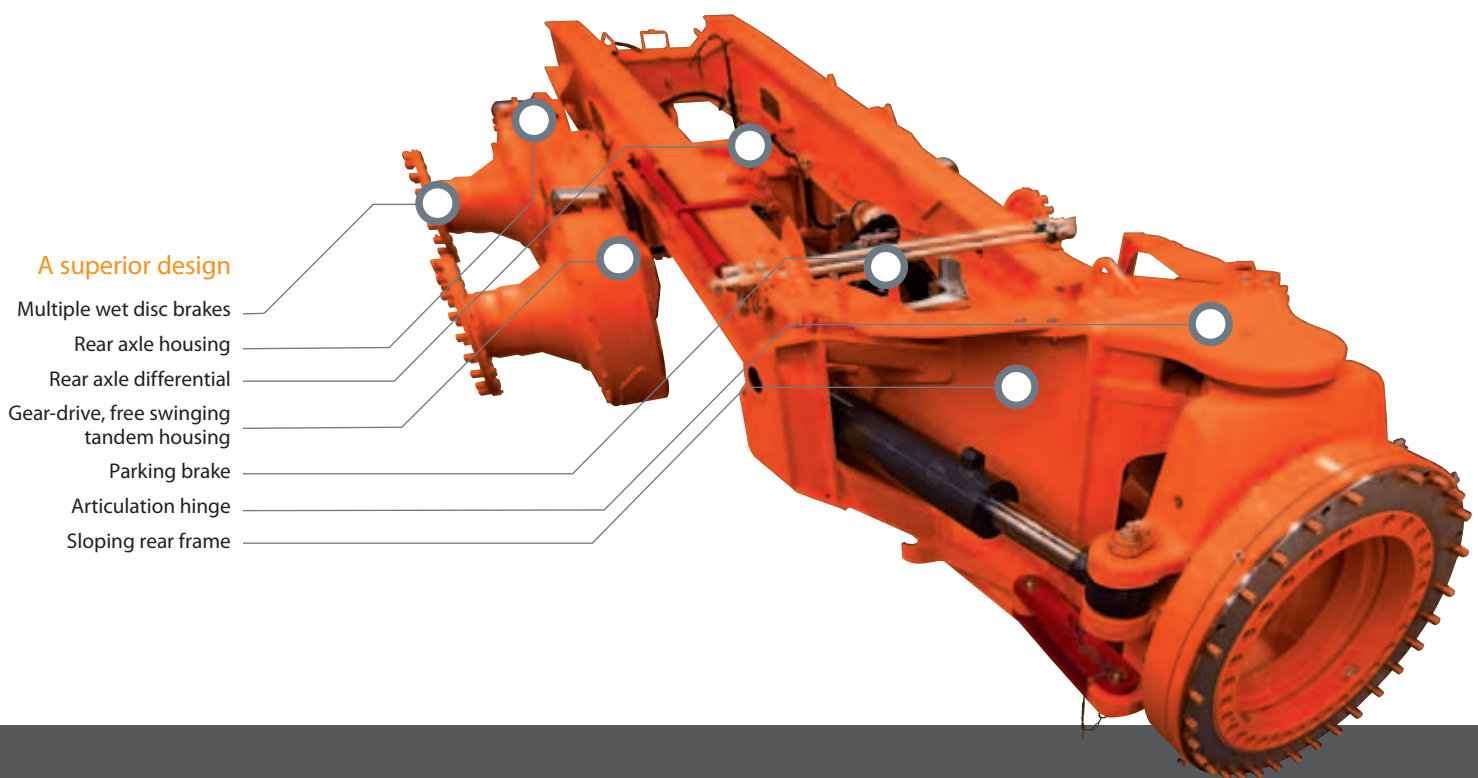

TOP 10 ADVANTAGES OF DOOSAN ARTICULATED DUMP TRUCKS

- Low operating cost
- Excellent performance in difficult terrain
- Independent front suspension ensures maximum ground contact and stability
- The sloping rear frame ensures a low centre of gravity, good stability and excellent weight distribution to the front axle
- Improved driver comfort and easy operation
- Easy and safe access to the cab
- Free-swinging rear tandem bogie ensures the best possible ground contact
- Front-mounted turning ring ensures equal weight distribution to the front axle in all situations
- Permanent 6-wheel drive, a significant advantage in rugged terrain
- Easy maintenance

Equipment

* Standard equipment

	DA30	DA40
Armrest at operator seat	•	•
Headrest at operator seat	•	•
Safety belt at operator and instructor seat	•	•
Adjustable steering column	•	•
All instrumentation in LCD display	•	•
Cigarette lighter and ashtray	•	•
12V charging point	•	•
Retractable roller sunblind	•	•
Tinted safety glass	•	•
Sliding window	•	•
Windshield wiper and washer	•	•
Mirror	•	•
Protection for rear window	•	•
Emergency steering, ground-driven	•	•
Towing hook, front and rear	•	•
Mud flaps	•	•
Automatic lubrication system Groeneveld	•	•
Engine exhaust brake	•	•
Transmission retarder brake	•	•
Rear view camera	•	•
Radio/CD/MP3	•	•
Work light front, at the top of the cab	•	•
Cab tilting system	•	•
Emergency shutdown switch	•	•
Wet disc brake	•	•
Anti-slip steps & platform	•	•
Space for cooler box	•	•
Storage room	•	•
Electronic climate control	•	•

* Optional equipment

	DA30	DA40
BODY OPTIONS		
Top tailgate	Std	•
Spill guard on front of body	•	•
Body heating system	•	•
Body lining standard	•	•
Body lining full	•	•
Side extensions (upon request)	•	•
Payload metre	•	•
CAB OPTIONS		
Deluxe seat	•	•
Heated operator seat	•	•
Heated mirror	•	•
OTHER		
Webasto heating system (heat up the cooling system)	•	•
Electrical engine heater	•	•
Fire extinguisher	•	•
First aid kit	•	•
Beacon	•	•
Light bar	•	•
Speed limitation	•	•
Work light kit (rear and front)	•	•
Work light kit (rear and front) LED	•	•
Automatic lubrication system Lincoln	•	•
Tool kit	•	•
Warning triangle	•	•
Fast fill	•	•
TYRE OPTIONS		
Quarry	•	•
Earthmoving	•	•
Flotation tyres	•	•

Heated body

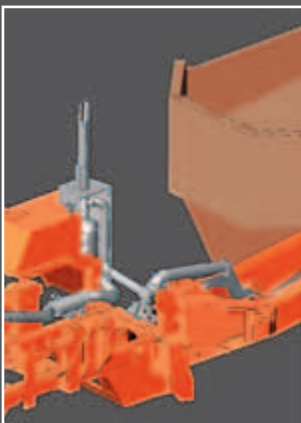

Fast fill



Quarry tyres



High flotation tyres



DA30

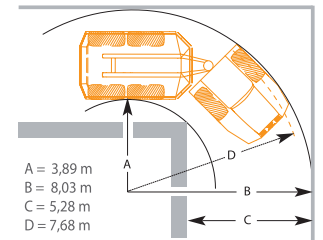
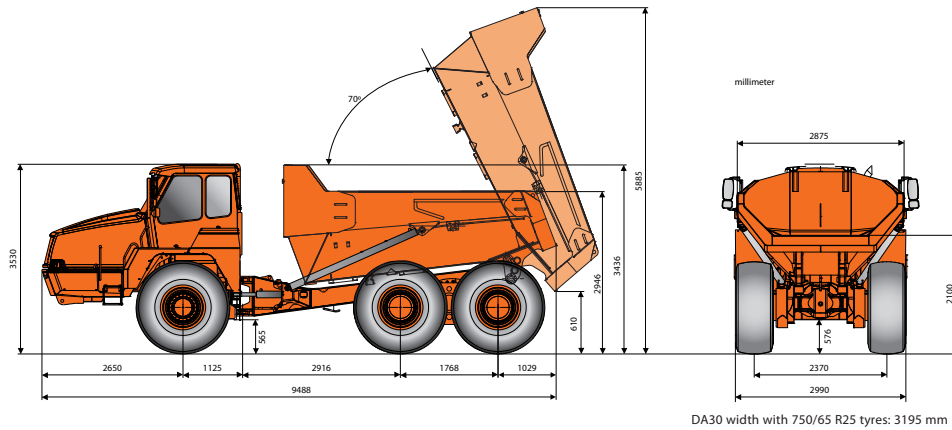

Turning radius according to ISO 7457: 7.68 m

DA40

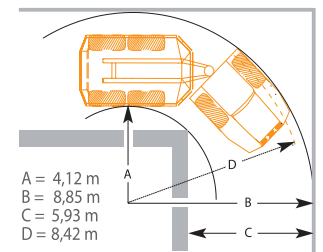
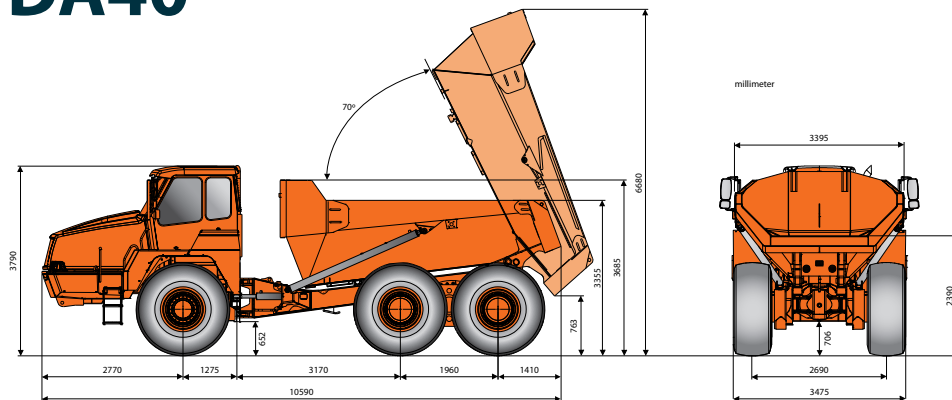

Turning radius according to ISO 7457: 8.42 m

DA30 - DA40

Suspension

- Front: DA30: Independent with long life rubber springs and hydraulic shock absorbers
- Front: DA40: Independent with two hydro-pneumatic cylinders
- Rear: Free-swinging tandem housing

Articulation hinge and steering

- Articulation hinge with forward-mounted turning ring
- Steering cylinders (two): Double-acting
- The steering is approved according to ISO 5010
- Max. steering angle: 45°
- Ground-driven emergency steering pump

Driveline

- Full-time 6 x 6 drive with two transverse differentials and one longitudinal
- Front axle transverse differential: Limited-slip diff lock with 45% locking ratio
- DA40: Rear axle transverse differential: Multi disc diff lock with 45% locking ratio
- DA30: Rear axle transverse differential: clutch-engaged
- Inter-axle longitudinal differential: Torque-proportioning differential, integrated into the ZF transmission
- Torque distribution:
 - 1/3 to the front axle
 - 2/3 to the rear axle
 - 100% lockable
- Tandem housing: Gear driven, free-swinging. Provides equal drive to rear wheels and ensures the best possible ground contact - whatever the ground conditions

Brake system

- Dual circuit braking system acting on all six wheels
- Approved according to ISO 3450
- All-hydraulic operated brakes with enclosed oil-cooled wet multiple discs all round
- Spring actuated hydraulic released parking brake, mounted on driveline shaft
- Max. gradient, parking brake: 20°
- Automatic engine brake as standard
- Automatic transmission retarder as standard

Cab

- Approved to ROPS/FOPS standards (ISO 3471, ISO 3449)
- Low interior sound level 73 dB(A) (ISO 6394)
- The cab is centrally located on rubber mountings
- Hand and arm vibrations are less than 2.5 m/s according to ISO 5349-2
- Whole body vibration is less than 0.5 m/s according to ISO 2631-1
- Superior visibility - for safer operation
- Superior operating controls location
- Adjustable suspended operator seat
- Adjustable steering column
- Climate control - Heater and air conditioning
- Tilting for service access

DA30

DA40

	DA30	DA40
Body		
Body volume	HB400 18 m ³ – 23.5 yd ³	HB400 24.4 m ³ – 31.9 yd ³
Material	Hardened abrasion-resistant steel plates	Hardened abrasion-resistant steel plates
Tilt cylinders	Single stage, double-acting	Single stage, double-acting
Tipping time	Up: 10 sec. / Down: 9 sec.	Up: 10 sec. / Down: 9 sec.
Body	Designed for exhaust heating	Designed for exhaust heating
Sloping frame	Down from the hinge point	Down from the hinge point
Level capacity (with / without tailgate)	14.2 m ³ / 13.6 m ³ – 18.6 yd ³ / 17.8 yd ³	20.4 m ³ / 19.6 m ³ – 26.7 yd ³ / 25.6 yd ³
Heaped capacity (with / without tailgate)	18 m ³ / 16.8 m ³ – 23.5 yd ³ / 22 yd ³	26 m ³ / 24.4 m ³ – 47.1 yd ³ / 31.9 yd ³
Density index	1.64 t/m ³	1.64 t/m ³
Weights		
Empty:	Front axle 11900 kg – 26235 lb Rear axle 11500 kg – 25353 lb	14500 kg – 31967 lb 15800 kg – 34833 lb
Loaded:	Front axle 16500 kg – 36376 lb Rear axle 34425 kg – 75894 lb	20700 kg – 45636 lb 49600 kg – 109349 lb
Pay load	28000 kg – 31 sh tn	40000 kg – 44 sh tn
Total weight (loaded)	51400 kg – 113317 lb	70300 kg – 154985 lb
Net weight	23400 kg – 51588 lb	30300 kg – 66800 lb
	NOTE: All weights include a full fuel tank and operator.	NOTE: All weights include a full fuel tank and operator.
Power to weight ratio		
Empty	Net Power vs Ton 12.1 kW/t	Net Power vs Ton 12 kW/t
Loaded	5.47 kW/t	5.20 kW/t
Ground pressures		
	Standard 23.5 x 25 tyres with 15% sinkage	Standard 29.5 x 25 tyres with 15% sinkage
Empty:	Front axle 104 kPa Rear axle 53 kPa	88 kPa 48 kPa
Loaded:	Front axle 141 kPa Rear axle 162 kPa	130 kPa 152 kPa
Capacities		
Fuel Tank	335 l	530 l
Hydraulic System	150 l	275 l
Engine Cooling System	45 l	50 l
Transmission	75 l	75 l
Engine Crankcase	33 l	34 l
Front Reduction Gear	2 x 11 l	2 x 7.5 l
Rear Differential	16 l	46 l
Tandem Housing	2 x 48 l	2 x 150 l
Rear Reduction Gear	4 x 7 l	-
Adblue® tank	38 l	38 l
Speeds		
	Forward	Reverse
1st	5 km/h	5 km/h
2nd	8 km/h	8 km/h
3rd	11 km/h	11 km/h
4th	16 km/h	16 km/h
5th	23 km/h	23 km/h
6th	32 km/h	32 km/h
7th	45 km/h	45 km/h
8th	58 km/h	58 km/h
Engine		
Complies with Stage IIIB of EU Directive 97/68/EC for emissions	Scania DC 9, water-cooled, diesel engine with turbo charger and air to air intercooler	Scania DC 13, water-cooled, diesel engine with turbo charger and air to air intercooler
Power rating (ISO 3046)	375 HP (276 kW)	500 HP (368 kW)
(ISO 9249)	365 HP (268 kW)	490 HP (360 kW)
No. of cylinders	5 (in line)	6 (in line)
Gross Torque	1873 Nm @ 1300 rpm	2373 Nm @ 1300 rpm
Engine exhaust brake	Yes	Yes
Cylinder volume	9.3 litres	12.7 litres
Air filter	Dry type	Dry type
Transmission	ZF 8 EP370 electronically-controlled automatic transmission with retarder	ZF 8 EP420 electronically-controlled automatic transmission with retarder
	The torque converter has automatic lock-up in all gears	The torque converter has automatic lock-up in all gears
Hydraulic system		
Pumps	1 variable displacement piston pump for steering & tipping for cooling fan, brakes & auxiliaries	2 variable displacement piston pumps for steering & tipping for cooling fan, brakes & auxiliaries
Delivery	320 l/min @ 2200 rpm	320 l/min @ 2200 rpm for steering, brakes and auxiliary tipping 60 l/min @ 2200 rpm for cooling fan and tipping
Filtration	One return flow filter	One return flow filter
Pressure-setting, main safety valves:		
Tipping Circuit	280 bar	280 bar
Steering Circuit	210 bar	210 bar
Electrical system		
Alternator	28V 100A	28V 100A
Batteries (two)	12V 140Ah (series connected to give 24V)	12V 225Ah (series connected to give 24V)
Starter	7.5 HP (5.5 kW)	7.5 HP (5.5 kW)
Tyres		
Standard	23.5 R25 two star radial	29.5 R25 two star radial

DOOSAN Infracore

The pulse of transformation



Construction Equipment

Machine Tools

Engines

The spirit of challenge and innovation has led Doosan. We started out as a small store in Seoul in 1896 and have expanded into a global company. Today we are engaged in the infrastructure support business (ISB), which encompasses industrial facilities, machinery, heavy equipment and construction. You can also see the Doosan brand in various other industries.

You are invited to take a closer look at the new world that is being built by Doosan, visit us at: www.doosaninfracore.com and www.doosanequipment.eu

