



Doosan Infracore
Construction Equipment

DX55

Engine Power : SAE J1349, net 41.5 kW(56.4HP)@2,000rpm

Operational Weight : 5,600 kg (11,904 lb)

Bucket capacity(SAE) : 0.175 m³ (0.229 cu.yd)



Photo may include optional equipment

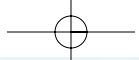

DX 55



The new DX55 hydraulic excavator has all the advantages of the previous model, and now offers additional added value to the operator.

The new DX55 was developed with the concept of "providing optimum value to the end user." In concrete terms, this translates, into :

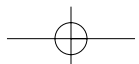



“When there’s more to do,
Doosan gets more done”

Increased production and improved fuel economy is attributed to the electronic optimization of the hydraulic system and the new generation engine.

Improved ergonomics increases comfort and excellent all around visibility ensuring a safe and pleasant working environment.

Improved reliability is achieved through the use of high performance materials combined with new methods of structural stress analysis, which leads to increased component life expectancy, thus reducing operating costs.

Reduced maintenance increases the availability and reduces operating costs of the excavator.

Comfort

DX55

This standard-duty machine, offers a spacious operating area that is only found in medium and heavy-duty machines. The working controls in the cabin are ergonomically designed to ensure convenience and comfort for the operator.



Comfortable Operating Area

The internal operating controls are arranged in a convenient and ergonomic fashion. This allows for maximized operating efficiency. A large capacity air-conditioning system has been installed for operator comfort in all seasons. The open and spacious cabin provides the operator with a wide field of view for the best possible working conditions.

Good visibility (visual field in 360°)

The operator's cabin is remarkably increased and good visibility is ensured thanks to the access improved by applying chassis to left and has excellent all round visibility.



Front window



Rear window

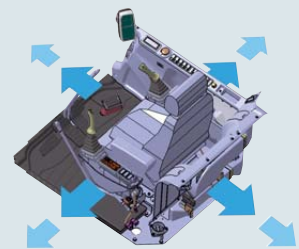

Sub window



Side mirror (Optional)



Thermometer for cooling water

Fuel gauge

Fixed-type LED Instrument Panel

Fixed-Type Instrument Panel

The centralized display panel provides comprehensive information about the status of the machine in an easy to read format. The high quality display panel is waterproof and all information can be seen at a glance.



Air-Conditioner Filter

High-Output Air-Conditioner and Defroster

The air-conditioner capacity has been greatly improved and the vents have been installed at both the front and rear of the operator's seat to maximize air-conditioning efficiency. A defroster has been installed to prevent the front windshield from becoming frosted in the cold season resulting in safer operation.



475mm (1'7")

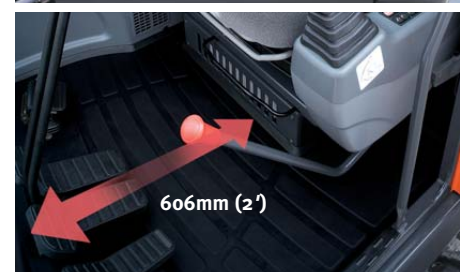

606mm (2')

Enlarged entrance and exit

As entrance and exit are enlarged, accessibility is improved for getting on and off the vehicle. Since the front workspace is maximized, the inconvenience in operating equipment is minimized.



Control Stand

The left and right control stands are ergonomically placed for convenient operation. The control stand surfaces have ample room to install several option switches. The uni-body plastic design provides the operator with a spacious and comfortable cabin environment.



Comfortable 2-stage sliding seat Comfortable tilting seat

Suspension Seat

Since the seat cushion position and cushion angle can be adjusted in addition to the 2-step slide control function, the seat can be controlled in accordance with personal preference convenience is further improved via the seat back pocket, lumbar support and seat heater. (Option)



Switch

The ergonomically placed switches maximizes convenience for the operator.



A/C Control Panel

As semi-automatic air conditioner is applied in 5 switching modes, it can be controlled in the position and performance desired by operator.



Dozer Control

The Dozer Control Lever is positioned above the right-hand control stand to secure easy and convenient access.



Floor Plate (Rubber mat)

The break pedal(left) and boom swing pedal(right) are installed in a very spacious and convenient location. In addition, the rubber floor mats contribute to a very comfortable environment.



Joystick

The hydraulic joystick levers have very comfortable grips that allow the operator to perform precise operations very easily. As there are 3 switches on the upper side, each attachment can be operated easily.



Wide Storage space



Seat back pocket



Rubber mounting

Performance

DX55

DX55 ensures best performance with a powerful excavating force and a high-tech hydraulic system for better operating efficiency at any work site! Excellent performance is its basic feature! Overall safety and convenience are also key factors when considering excellent performance.



Boom swing

The convenient boom swing function provides the ability to work in very narrow areas. The newly designed swing bracket and the boom swing cylinder size ensures powerful and stable boom swing performance.

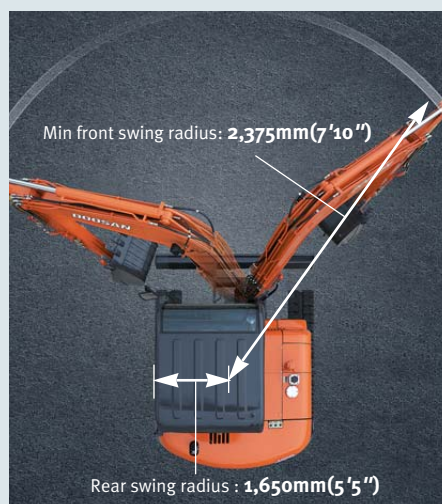

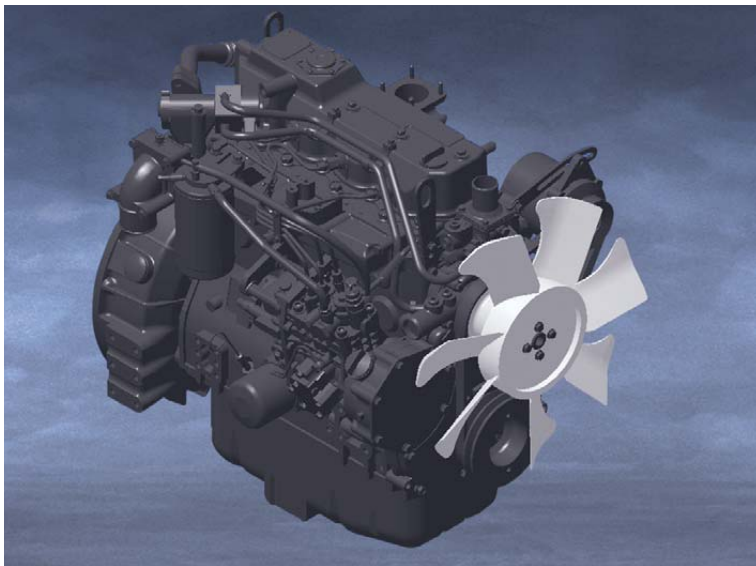

YANMAR 4TNV98-Z

The 56.4HP(SAE J1349, net) engine produces outstanding power and is known for its durability. This results in excellent operation in high-load operations. In addition, it features a low noise and low emissions suitable for operation in noise sensitive areas and at night.



RPM dial / Auto idle

Thanks to electronic engine rpm control, the optimal engine rpm can be set as per workload and engine rpm can be minutely adjusted as per load. Since auto idle function is applied as standard, fuel is saved considerably.



Auto Fuel feed Pump

To reduce inconvenience in dispensing fuel at the work site, an auto fuel feed pump has been installed.



Blow out

As the temperature of air flowing into cabin is lowered by discharging the air flowing from outside to radiator, agreeable work environment is ensured in the cabin.



Dozer Blade

Welded, unitized blade provides durability even under harsh working conditions.



Main Pump

Displacement 10%

As the displacement of main pump is increased by 10% compared to the old model, rated rpm is decreased by 9%, thereby reducing noise and saving fuel.*



Higher greadability and work capability

Thanks to the strong driving force based on high performance engine power and the highest swing limit angle in the same class, the product shows distinguished capability in working on the slope.



Increased diameter of boom cylinder

As the size of boom cylinder is increased by 4.5% compared to the existing model, hoisting force and jack up performance are enhanced, thereby improving the equipment movability.*

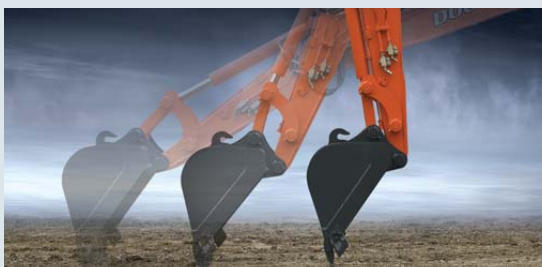

Front lamp

Main control valve

The machine can be precisely controlled in the single and complex operation. For complex operation, the circuit that ensures the optimal front operation is adopted. Thanks to boom holding function, it prevents the boom from self-lowering.

* The measured value is based on our test and the compared equipment is Doosan V model.

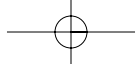

Reliability

DX55

The reliability of a machine contributes to its overall lifetime operating costs. DOOSAN uses computer-assisted design techniques, highly durable materials and structures which are tested under extreme conditions. Durability of materials and longevity of structures are our first priorities.

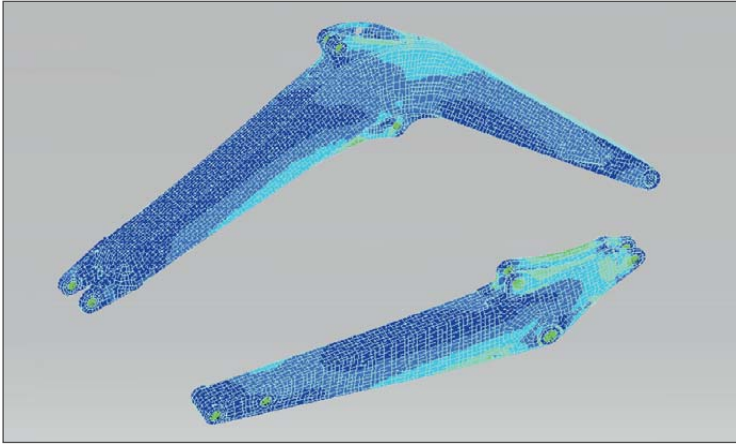

Strengthened Boom

The shape of the boom has been optimized by finite elements design, allowing uniform load distribution throughout the structure. This combined with increased material thickness means improved durability and reliability by limiting element fatigue.

Arm Assembly

In the arm assembly greater strength has been gained by using cast elements and reinforcement around the bosses to give increased life.

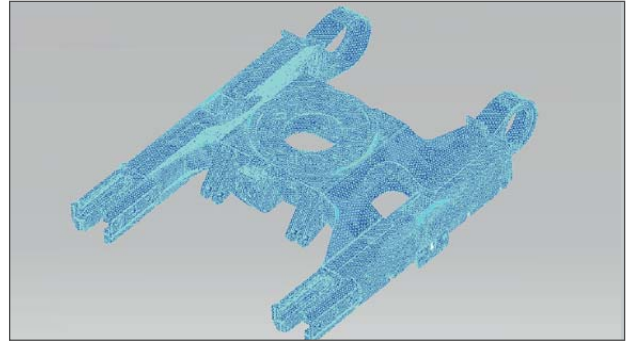

X-chassis

The X-chassis frame section has been designed using finite element and 3-dimensional computer simulation, to ensure greater durability and optimum structural integrity. The swing gear is solid and stable.

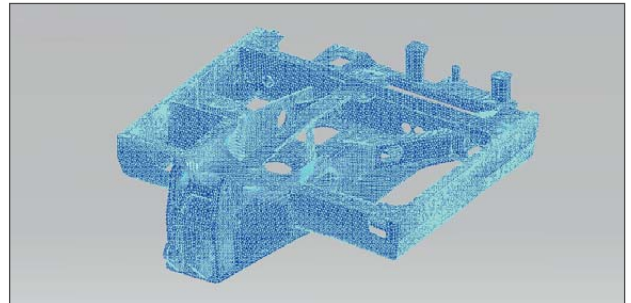

D-type Frame

The D-type frame design adds strength and minimizes distortion due to shocks.



Rubber tracks

The rubber shoes not only offers greater non-slip and grip capabilities but is less harmful to sidewalks and road surfaces in urban environments than conventional steel shoes. These rubber shoes can be easily installed or removed with the idler, sprocket and other main parts.



Bushing

A highly lubricated metal(sintered bushing) is used for the boom, arm and bucket pivot in order to increase the lifetime and extend the greasing intervals to 250 hours.



Polymer shim

As polymer shim is adopted, the connection and wear on the lateral surface of pin joint is prevented when operating front.

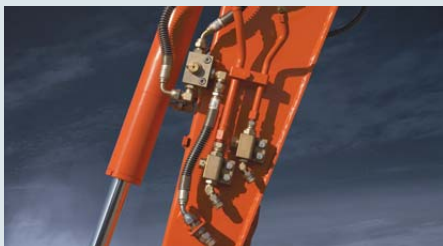

Front oil leakage preventing valve

As the operating method of the valve is improved, oil does not leak even under high pressure, thereby ensuring the stable work performance.



Head lamp cover

Head lamp is protected by head lamp cover.



Combination key

As a multi key is applied to the chrome-coated knob and fuel cap, security is enhanced.



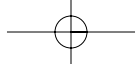

Integrated Track Spring and Idler

The track spring and the idler have been joined directly to achieve high durability and improved maintenance convenience.



Lower track roller

Strength 75%

As casting product is replaced by forging product, strength is increased by 75% compared to the existing model, thereby improving wearproof property.*



Prefabricated Track Guard

The track guard, which protects the vital track components is a prefabricated component and allows for easy replacement.

* The measured value is based on our test and the compared equipment is Doosan V model .



Maintenance

DX55

The most advanced technology developed by Doosan was integrated into the DX55 excavator providing powerful performance and simple, easy maintenance. This provides the operator with convenient maintenance check points and maximizes the work efficiency of the DX55.



Easy maintenance

Access to the radiator and cooler is very easy, making cleaning simple. Access to the various parts of the engine is from the side.



Countweight & hood

As a cast counterweight is applied, deformation by impact is minimized. Thanks to the bonnet made of metton, the engine is further protected from external obstacle.



Radiator

The large-capacity radiator provides excellent performance in severe and continuous operations.



Oil filter/Fuel filter

The engine oil filter is attached to the engine body and extends out for easy maintenance.



Air Breather

The mounted large-capacity air breather protects the pump from possible damage that may be caused by cavitations. Since only internal element instead of the entirety can be replaced when exchanging, it is more practical.

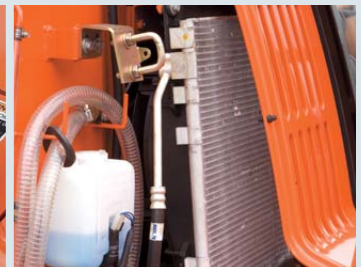

Condenser

As separated type condenser is attached, it shows excellent refrigerating performance and makes cleaning even easier.



Oil Gauge

Hydraulic oil level can be easily checked through the gauge on the side of the hydraulic tank.



Grease Piping

Integrated grease piping is designed for easy maintenance of the swing bearing and swing cylinder.



Air cleaner

The large capacity forced air cleaner removes over 99% of airborne particles, reducing the risk of engine contamination, making the cleaning and cartridge change intervals greater.



Muffer

As a small muffer is applied, noise and heat is minimized.



Battery
Opening the battery cover, the operator can easily check the parts.



Water separator
Since water separator is used to prevent the malfunction of fuel system caused by water in fuel, the operator can easily check it on the gauge.



Compressor Check up interval 250Hrs
Sufficient space is provided for easy fan belt tension adjustment or replacement. As check-up intervals are considerably increased to 250Hrs by attaching a B-type belt, servicing is made far more convenient.



Engine mounting rubber
As a sandwich-typed engine mounting rubber with excellent durability and dustproof property is adopted, the engines vibration is not transmitted to the machine.

DX55

Technical specifications

ENGINE

Model	4TNV98-Z
Number of cylinders	4
Nominal flywheel power	41.5 kW(56.4HP) @ 2,000 rpm (SAE J1349, net)
Max torque	25.3 kgf.m(248.1 Nm) at 1,300 rpm
Piston displacement	3,319 cc (202.5 cu.in)
Bore & stroke	∅98 mm x 110 mm (3.9" X 4.3")
Starter	12 V / 3 kW
Batteries	1 x 12 V / 100 Ah
Alternator	12 V / 60 A

HYDRAULIC CYLINDERS

High-strength piston rods and tubes are used.

A cylinder cushion mechanism is provided for the boom and arm cylinders to assure shock-free operation and extend the life of the cylinders.

Cylinders	Quantity	Bore x Rod diameter x stroke
Boom	1	115 X 60 X 719mm(4.5" X 2.4" X 2'4")
Arm	1	90 X 60 X 883mm(3.5" X 2.4" X 2'11")
Bucket	1	85 X 55 X 600mm(3.3" X 2.2" X 2')
Dozer	1	110 X 60 X 183mm(4.3" X 2.4" X 7.2")
Boom swing	1	110 X 55 X 558mm(4.3" X 2.2" X 1'10")

HYDRAULIC SYSTEM

2 Variable displacement axial piston tandem type pumps.
 2 Gear pumps and control valve (11-spool) of section block construction.
 This original design enables both independent and combined operations of all function, joystick control type operations.

Main pumps	2 variable displacement axial piston pumps max flow: 2 x 55 ℓ /min(14.5 US gpm, 12.1 Imp gpm) 1 gear pump max flow: 36.6 ℓ /min(9.7 US gpm, 8.1 Imp gpm)
Pilot pump	Gear pump - max flow: 13 ℓ /min (3.4 US gpm, 2.9 Imp gpm)
Relief valve setting	Implement circuit: 245 kgf/cm ² (240 bar) Travel circuit: 210 kgf/cm ² (205 bar) Swing circuit: 210 kgf/cm ² (205 bar) Pilot circuit: 34 kgf/cm ² (33.3 bar)

OPERATOR'S CAB

A roomy, independent, shock and noise-free operator's cab, four-side safety glass windows gives all-round visibility.

Front window slides up and stores in the roof and side window can be opened for ventilation. Fully adjustable suspension seat. Air conditioner. ISO standard cab.

Noise Levels (dynamic value)

LwA External noise

Guaranteed Sound Power Level 98dB (A) (2000/14/EC)

LpA Operator noise

78dB (A) (ISO 6396)

SUPER-STRUCTURE REVOLVING FRAME

A deep, full-reinforced box section. Heavy gauge steel plates used for ruggedness.

CONTROL. 2 IMPLEMENT LEVERS

Travel lever pedal pilot pressure control type. Right lever is boom and bucket control, left lever for swing and arm control.

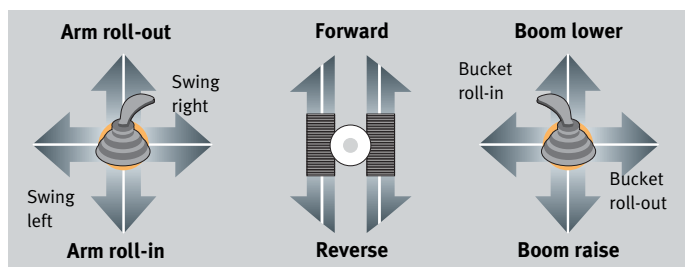

SWING MECHANISM

High-torque, axial piston motor with planetary reduction gear bathed in oil. Swing circle is single-row, shear type ball bearing with induction-hardened internal gear. Internal gear and pinion gear immersed in lubricant. Swing parking brake is spring-set, hydraulic-released disc type.

Swing speed	9.8 rpm
Rear swing radius	1,650 mm (5'5")

DRIVE

Each track is driven by an independent, high-torque, axial piston motor through planetary reduction gears. Two levers of foot pedal control provide smooth travel or counter-rotation upon demand.

Travel speed(High/Low)	4/2.4 km/h (2.4 /1.5 mph)
Maximum traction force	4.7/2.5 ton (10,361 /5,511 lbf)
Maximum grade	35° / 70%

UNDERCARRIAGE

Tractor type undercarriage. Heavy-duty track frame, all welded stress-relieved structure. Top grade materials are used for toughness. Side frames are welded, securely and rigidly, to the track frame. Lifetime-lubricated track rollers, idlers with floating seals.

BUCKET

Capacity		Width		Weight	Recommendation	
					3,000mm (9'10") Boom	
PCSA, heaped	CECE heaped	Without side cutters	With side cutters		1,600mm (5'3")Arm	1,900mm (6'3")Arm
0.175m ³ (0.229yd ³)	0.15m ³ (0.196yd ³)	654mm (2'2")	724mm (2'5")	141 kg (311 lb)	B	B
0.07m ³ (0.092yd ³)	0.06m ³ (0.078yd ³)	300mm (1')	362mm (1'2")	96 kg (212 lb)	A	A

A. Suitable for materials with density of 2,000 kg/m³ (3,370 lb/CU · yd) or less
 B. Suitable for materials with density of 1,600 kg/m³ (2,700 lb/CU · yd) or less
 C. Suitable for materials with density of 1,100 kg/m³ (1,850 lb/CU · yd) or less

BRAKE

Two oil disc brakes on final drive input shafts. When machine is stationary brakes are set automatically. Operating either travel lever disengages brakes.

WEIGHT

Boom 3,000 mm (9'10") / Arm 1,600 mm (5'3") / Bucket SAE 0.175 m³ (0.229 yd³)

Shoe Width	Operating Weight	Ground Pressure
400 mm (1'4")	5,600 kg (12,346 lb)	0.32 kgf/cm ² (31 kpa, 4.5psi)

REFILL CAPACITIES

Fuel tank	115℥ (30.4 US gal, 25.29 Imp gal)
Cooling system (Radiator capacity)	10℥ (2.64 US gal, 2.20 Imp gal)
Engine oil	11.6℥ (30.6 US gal, 2.55 Imp gal)
Final drive (each)	1.2℥ (0.32 US gal, 0.26 Imp gal)
Hydraulic system	90℥ (23.8 US gal, 19.8 Imp gal)
Hydraulic tank	73℥ (19.29 US gal, 16.05 Imp gal)

DX55

Dimensions & Working range

DIMENSIONS

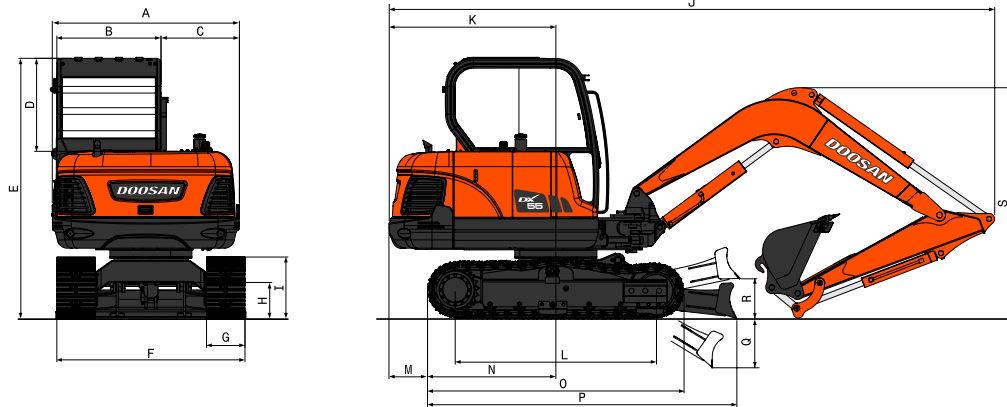

Boom type	3,000mm(9'10")	
Arm type	1,600mm(5'3")	1,900mm(6'3")
A Overall width of upper structure	1,850mm(6'1")	†
B CAB. width	1,075mm(3'6")	†
C Distance from cabin to counterweight	775mm(2'7")	†
D Height from bonnet to cabin	920mm(3)	†
E Overall height of cab	2,500mm(8'2")	†
F Overall track width	1,880mm(6'2")	†
G Track shoe width	400mm(1'4")	†
H Ground clearance	365mm(1'2")	†
I Track height	590mm(1'11")	†
J Overall length	5,900mm(19'4")	5,970mm(19'7")
K Tail length	1,650mm(5'5")	†
L Tumbler distance	1,990mm(6'6")	†
M Tail to track clearance	400mm(1'4")	†
N End distance of track	1,250mm(4'1")	†
O Track length	2,500mm(8'2")	†
P Track to dozer length	2,975mm(9'9")	†
Q Height of dozer down	575mm(1'10")	†
R Height of dozer up	350mm(1'2")	†
S Boom height	1,985mm(6'6")	2,175mm(7'2")

DIGGING FORCE (ISO)

Bucket (PCSA)	0.07m ³	0.175m ³
Digging force	4,200 kgf	4,200 kgf
	41.2 kN	41.2 kN
	9,259 lbf	9,259 lbf
Arm	1,600mm(5'3")	1,900mm(6'3")
Digging force	2,800 kgf	2,500 kgf
	27.5 kN	24.6 kN
	6,173 lbf	5,519 lbf

WORKING RANGE

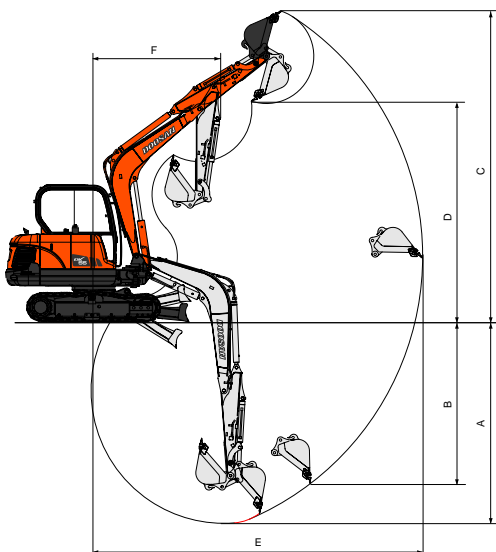

Boom type	3,000mm(9'10")	
Arm type	1,600mm(5'3")	1,900mm(6'3")
Bucket type (SAE)	0.175m ³ (0.229yd ³)	0.175m ³ (0.229yd ³)
A Max. Digging Depth	3,785mm(12'5")	4,085mm(13'5")
B Max. Vertical Wall	3,110mm(10'2")	3,400mm(11'2")
C Max. Digging Height	5,810mm(19'1")	6,010mm(19'9")
D Max. Dump Height	4,080mm(13'5")	4,280mm(14')
E Max. Digging Reach	6,160mm(20'3")	6,450mm(21'2")
F Min. Swing Radius	2,365mm(7'9")	2,380mm(7'10")

DX55

Lifting Capacity

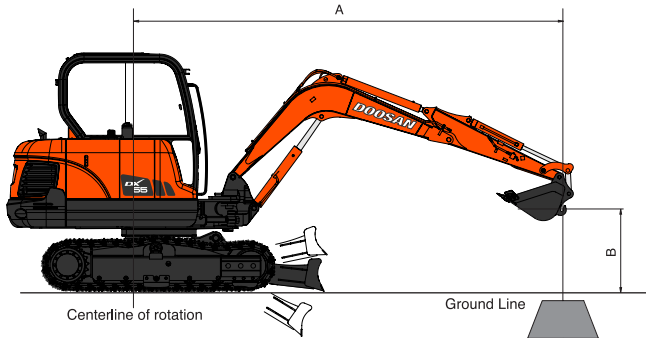

Boom : 3,000mm(9'10")
 Arm : 1,600mm(5'3")
 Bucket : 0.175m³ (0.229yd³)
 Shoe : 400mm(1'4")

Dozer down

Metric

Unit : 1,000kg

A(m)	2		3		4		5		Max. Reach		A(m)
4					*0.97	0.86			*0.86	0.73	4.37
3					*1.06	0.84			*0.86	0.58	4.96
2	*3.06	2.39	*1.68	1.26	*1.34	0.81	*1.23	0.56	*0.92	0.51	5.26
1			*2.49	1.17	*1.69	0.76	*1.38	0.54	*1.03	0.49	5.32
O (Ground)	*1.78	*1.78	*2.95	1.11	*1.95	0.73	*1.50	0.52	*1.24	0.50	5.16
-1	*2.95	2.11	*3.03	1.10	*2.04	0.72			*1.61	0.56	4.75
-2	*4.51	2.14	*2.76	1.11					1.84	0.74	3.99
-3	*3.03	2.23							*2.34	1.59	2.45

Feet

Unit : 1,000lb

A(ft)	10		15		Max. Reach		A(ft)
15					*1.97	*1.97	12.59
10					*2.42	1.48	16.21
5	*4.49	2.61	*3.01	1.40	*2.12	1.09	17.44
O (Ground)	*6.35	2.40	*3.65	1.32	*2.72	1.10	16.93
-5	*6.35	2.38			*3.79	1.39	14.45
-10					*5.28	3.84	7.62

Dozer up

Metric

Unit : 1,000kg

A(m)	2		3		4		5		Max. Reach		A(m)
4					*0.97	0.86			*0.86	0.73	4.37
3					*1.06	0.84			*0.86	0.58	4.96
2	*3.06	2.39	*1.68	1.26	1.33	0.81	0.93	0.56	0.86	0.51	5.26
1			2.00	1.17	1.28	0.76	0.91	0.54	0.83	0.49	5.32
O (Ground)	*1.78	*1.78	1.94	1.11	1.25	0.73	0.90	0.52	0.86	0.50	5.16
-1	*2.95	2.11	1.92	1.10	1.24	0.72			0.96	0.56	4.75
-2	4.05	2.14	1.94	1.11					1.25	0.74	3.99
-3	*3.03	2.23							*2.34	1.59	2.45

Feet

Unit : 1,000lb

A(ft)	10		15		Max. Reach		A(ft)
15					*1.97	*1.97	12.59
10					*2.42	1.48	16.21
5	4.40	2.61	2.34	1.40	1.85	1.09	17.44
O (Ground)	4.16	2.40	2.26	1.32	1.89	1.10	16.93
-5	4.14	2.38			2.38	1.39	14.45
-10					*5.28	3.84	7.62

1. The weight of bucket is 142kg
 2. Load point is the hook on the back of the bucket

3. *Rated loads are based on hydraulic capacity
 4. Rated loads do not exceed 87% of HYD. Capacity or 75% of tipping capacity.

: Rating Over Front
 : Rating Over Side or 360 degree

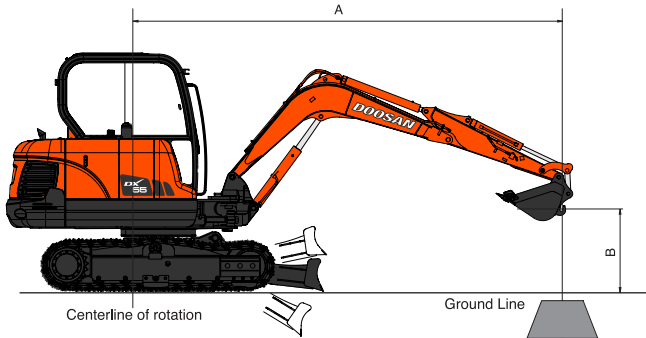
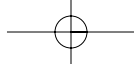

Boom : 3,000mm(9'10")
 Arm : 1,900mm(6'3")
 Bucket : 0.175m³ (0.229yd³)
 Shoe : 400mm(1'4")

Dozer down

Metric

Unit : 1,000kg

B(m)	2		3		4		5		Max. Reach		A(m)
4									*0.74	0.64	4.75
3					*0.91	0.85			*0.73	0.52	5.29
2			*1.39	1.28	*1.20	0.81	*1.01	0.57	*0.77	0.46	5.56
1	*1.43	*1.43	*2.25	1.18	*1.56	0.76	*1.12	0.56	*0.85	0.44	5.62
O (Ground)	*1.71	*1.71	*2.83	1.11	*1.87	0.73	*1.30	0.53	*0.99	0.45	5.47
-1	*2.61	2.08	*3.03	1.09	*2.02	0.71	*1.45	0.51	*1.27	0.49	5.09
-2	*3.90	2.10	*2.87	1.09	*1.93	0.71	*1.50	0.51	*1.66	0.62	4.40
-3	*3.72	2.17	*2.16	1.13					*2.00	1.05	3.15

Feet

Unit : 1,000lb

B(ft)	10		15		Max. Reach		A(ft)
15					*1.69	*1.69	14.01
10			*2.11	1.49	*1.62	1.14	17.28
5	*3.92	2.64	*2.77	1.40	*1.77	0.98	18.43
O (Ground)	*6.09	2.39	*3.51	1.31	*2.19	0.98	17.96
-5	*6.45	2.34	*3.67	1.28	*3.38	1.20	15.67
-10	*4.51	2.45			*4.47	2.43	10.06

Dozer up

Metric

Unit : 1,000kg

B(m)	2		3		4		5		Max. Reach		A(m)
4									*0.74	0.64	4.75
3					*0.91	0.85	0.95	0.57	*0.73	0.52	5.29
2			*1.39	1.28	*1.20	0.81	0.93	0.56	*0.77	0.46	5.56
1	*1.43	*1.43	2.01	1.18	1.28	0.76	0.91	0.53	0.76	0.44	5.62
O (Ground)	*1.71	*1.71	1.93	1.11	1.24	0.73	0.89	0.51	0.78	0.45	5.47
-1	*2.61	2.08	1.91	1.09	1.22	0.71	0.88	0.51	0.86	0.49	5.09
-2	*3.90	2.10	1.91	1.09	1.23	0.71			1.07	0.62	4.40
-3	*3.72	2.17	1.96	1.13					1.81	1.05	3.15

Feet

Unit : 1,000lb

B(ft)	10		15		Max. Reach		A(ft)
15					*1.69	*1.69	14.01
10			*2.11	1.49	*1.62	1.14	17.28
5	*3.92	2.64	2.34	1.40	1.68	0.98	18.43
O (Ground)	4.16	2.39	2.24	1.31	1.71	0.98	17.96
-5	4.10	2.34	2.22	1.28	2.08	1.20	15.67
-10	4.22	2.45			4.18	2.43	10.06

1. The weight of bucket is 142kg
 2. Load point is the hook on the back of the bucket

3. *Rated loads are based on hydraulic capacity
 4. Rated loads do not exceed 87% of HYD. Capacity or 75% of tipping capacity.

: Rating Over Front
 : Rating Over Side or 360 degree



DX55

Standard & Optional equipment

STANDARD EQUIPMENT

Hydraulic system

- Arm flow regeneration
- Boom holding valves
- Spare port(valve)

Cabin & Interior

- Rubber cab mount
- Air conditioner
- Adjustable suspension seat with head rest and adjustable arm rest
- Pull-up type front window and removable lower front window
- Room light
- Intermittent windshield wiper
- Storage box (including Cup holder)
- Engine speed(RPM) control dial
- AM/FM radio and cassette player
- Remote radio ON/OFF switch
- 12V spare powers socket
- Serial communication port for laptop PC interface
- Joystick lever with 3 switches
- Aircon filter
- Glass antenna

Safety

- Large handrails
- Seat belt
- Hydraulic safety lock lever
- Safety glass
- Hammer for emergency escape
- Emergency engine stop

Undercarriage

- Hydraulic track adjuster
- Track guards (Steel track)
- 400mm shoe
- 1,880mm dozer blade

Others

- Double element air cleaner
- Engine overheat prevention system
- Engine restart prevention system
- Self-diagnostic system
- Alternator(12V, 60 amps)
- Electric horn
- Halogen working lights(frame mounted 2, boom mounted 2)
- Auto idle

OPTIONAL EQUIPMENT

In some markets optional equipment may not be available and may also be of standard type only. It is advisable to contact the local Doosan dealer for information on availability and specific application requirements.

Safety

- Boom lock valve
- Overload warning device
- Travel alarm
- Rotation beacon
- Accumulator
- Left Review Mirror

Cabin & Interior

- Seat Heater
- AM/FM radio and MP3/CD player
- Additional working lamp
- Sunvisor

Others

- Piping for tilt
- Piping for quick clamp
- Fuel feed pump

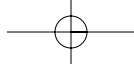

Seoul Office :
 Doosan Tower 27th FL. 18-12, Euljiro-6 Ga,
 Jung-Gu, Seoul, Korea 100-730
 Tel : +82-2-3398-8049
 Fax : +82-2-3398-8117
www.doosaninfracore.com

Doosan Infracore Europe S.A.
 1A, Rue Achille Degrace, 7080 Frameries, Belgium
 Tel : +32-65-61-3230 Fax : +32-65-67-7338

Doosan Infracore U.K., Ltd.
 Doosan House, Unit 6, 3 Heol Y Gamlas, Parc Nantgarw, Nantgarw,
 Cardiff. CF15 7QU, U.K.
 Tel : +44-1443-84-2273 Fax : +44-1443-84-1933

Doosan Infracore Europe S.A. Germa
 Heinrich-von- Stephan str. 2 40764 Langenfeld, Germany
 Tel : +49-2173-2035-210 Fax : +49-2173-2035-219

Doosan Infracore France
 ZAC de La Clef Saint Pierre - Buroplus 2 1A Avenue Jean d'Alembert
 78990 Elancourt, France
 Tel : +33-(0)1-30-16-21-41 Fax : +33-(0)1-30-16-21-44

Doosan Infracore America Corporation
 2905 Shawnee Industrial Way, Suwanee, Georgia 30024, U. S. A
 Tel : +1-770-831-2200 Fax : +1-770-831-0480

Doosan Infracore China Co., Ltd.
 #28, Wuzhishan Road, Eco. & Tech, Development Zone,
 Yantai, Shandong, China
 Tel : +86-535-638-2000 Fax : +86-535-638-2004

Doosan Infracore South Africa (PTY) LTD.
 60C Electron Road, Isando 1600, Johannesburg, South Africa
 Tel : 27-11-974-2095 Fax : 27-11-974-2778

Doosan Infracore Middle East Center (Dubai)
 P.O.Box 183127, Al-Serkal Building, Air Port Road, Dubai, U.A.E
 Tel : +971-4-295-2781~2 Fax : +971-4-295-2783

Doosan Infracore do Brasil ServiçOs de Suporte Comercial Ltda.
 Alameda Santos 2222 Cj52 CEP 01418.200 São Paulo, SP, Brasil
 Tel : +55-11-3061-3227 Fax : +55-11-3061-2731

Doosan Infracore India Pvt.Ltd
 Plot No. 34, Door No. 1/61-19, Palwels street, Ravi Colony,
 St. Thomas Mount, Chennai-600 016
 Tel : +91-44-4222-3900 Fax : +91-44-4222-3905

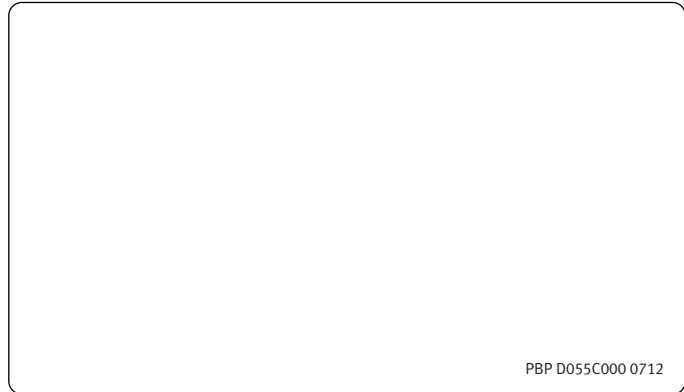

PBP D055C000 0712

The illustrations do not necessary show the product in standard version.
 All products and equipment are not available in all markets.
 Materials and specifications are subject to change without prior notice.

