

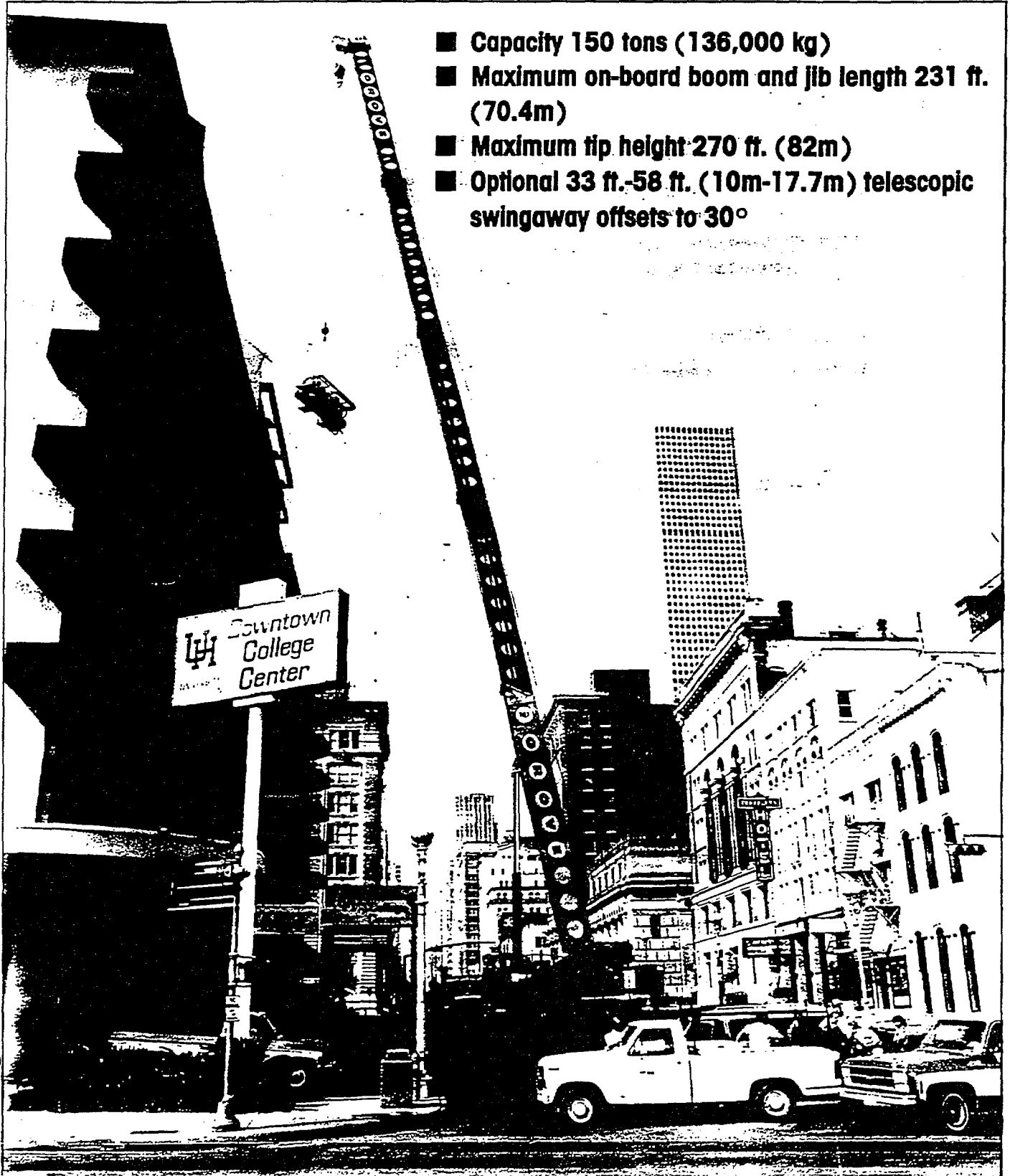

TM1500

Truck-mounted hydraulic crane



- Capacity 150 tons (136,000 kg)
- Maximum on-board boom and jib length 231 ft. (70.4m)
- Maximum tip height 270 ft. (82m)
- Optional 33 ft.-58 ft. (10m-17.7m) telescopic swingaway offsets to 30°

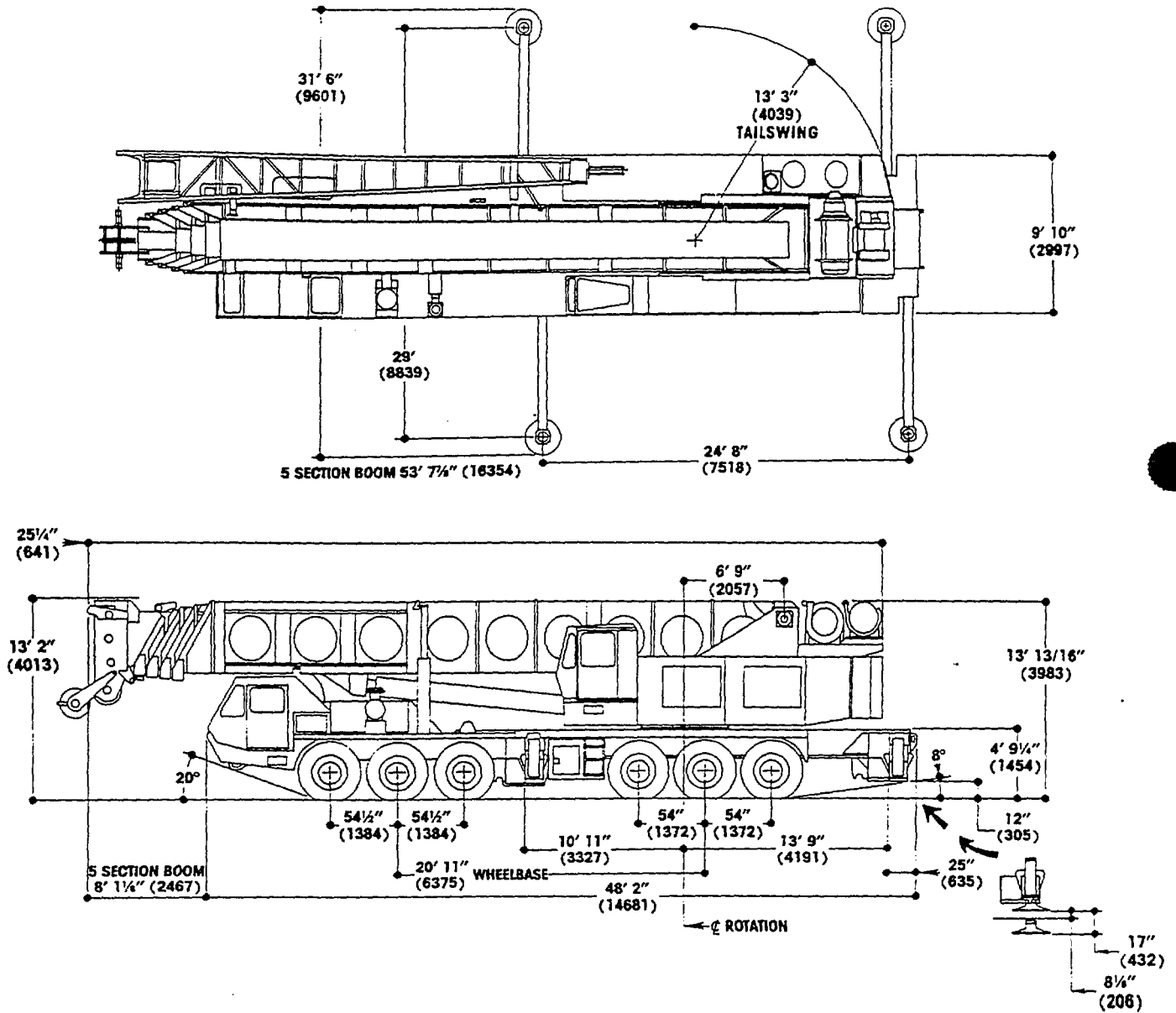

Distributed By

Constant improvement and engineering progress makes it necessary that we reserve the right to make specification, equipment, and price changes without notice. Illustrations shown may include optional equipment and accessories and may not include all standard equipment.

North and South America, Far East, Australasia

GROVE MANUFACTURING COMPANY
 Box 21 • Shady Grove • Pennsylvania 17256
 (717) 597-8121 • telex: 842308 • fax: (717) 597-4062

Europe, Africa, Middle East, Indian Sub-continent

GROVE COLES LTD.
 Telford Rd. • Bicester • Oxfordshire OX6 0TZ
 (0869) 246800 • telex: 837447 • fax: 0869-246965

Carrier specifications

Frame	High strength alloy steel all welded box-type construction with integral outrigger housings and front/rear lifting, towing and tie down lugs.
Outrigger System	Hydraulic double stage double box telescopic beam and jack outriggers with integral holding valves. All steel fabricated quick release type outrigger floats 30.5 in. (775mm) diameter. Standard fifth front stabilizer for 360° duties.
Outrigger Controls	Located in the superstructure cab and on both sides of the carrier frame. Push button controls requiring two-handed operation for safety. Crane level indicator (sight bubble) adjacent to each set of controls.
Engine	GM8V-92TA, eight cylinder turbo-charged water cooled diesel, 736 cu. in. (12.1 L), 430 hp (321 kw) (Gross) @ 2100 RPM. Maximum net torque 1123 ft. lbs. (169 kg/m) @ 1400 RPM.
Fuel Tank Capacity	(1) 100 gallons (378.5 L)
Electrical System	Four 12 volt - maintenance free batteries, 24 volt starting.
Drive	12 x 6
Steering	Front axle steering, cam and lever type with hydraulic assist.
Transmission	Fuller Roadranger, 9 speeds forward, 2 reverse.
Axes	Front: (3) Rockwell tubular steering FL951, 100 in. (2540mm) track. Rear: (3) Rockwell EPRC 1735 planetary drive, 85 in. (2159mm) track.
Suspension	Front axles (3) spring mounted tridem. Rear axles (3) solid mount tridem with equalizing beams.
Tires	Michelin 14:00x20-22PR (G-20X) radial ply tires front and rear.
Brakes	Full air on all wheels. Air dryer provided to preclude moisture accumulation. Spring set emergency brake on all rear axles with emergency release.
Lights	Full lighting including head, tail, braking, reversing, directional and hazard warning lights.

Cab	Two man design, all steel fabricated with acoustical lining and tinted safety glass throughout. Deluxe fabric covered fully adjustable seat. Complete driving controls and engine instrumentation including tachometer, speedometer, voltmeter, water temp. oil pressure, fuel level, air pressure gauge with A/V warning. Other standard items include hot water heater/defroster, electric windshield wash/wipe, fire extinguisher, seat belt and door and window locks.
------------	--

Maximum Speed	42.1 MPH (67.3 kph)
	BASIC STANDARD MACHINE
Gross Vehicle Weight & Axle Loads	Front: 57,341 lbs. (26,010 kgs) Rear: 134,796 lbs. (61,143 kgs) G.V.W.: 192,137 lbs. (87,153 kgs)
Miscellaneous Standard Equipment	Dual rear view mirrors, hookblock stowage trough, electronic back-up alarm, light package. Jacobs engine brake and tire inflation kit.
Optional Equipment	Immersion engine block heater, engine low oil pressure/high water temperature, audio visual warning.

†Patented Grove feature or patent pending.
*Denotes optional equipment.

Superstructure specifications

	46 ft. to 173 ft. (14m - 53m) five section Trapezoidal† full power boom. Each boom section has individually controlled telescope sections supported on graphite impregnated nylon wear pads. Maximum tip height: 182 ft. (55m).
Swingaway Extension	33 ft. (10.1m) lattice swingaway boom extension stows alongside base boom section when not in use, offsettable at 2°, 15° or 30°. Maximum tip height: 215 ft. (66m).
*Optional Telescopic Swingaway	33 ft. to 58 ft. (10m-18m) telescopic lattice swingaway extension with offset links, offsettable at 2°, 15° or 30°. Stows alongside base boom when not in use. Maximum tip height: 240 ft. (73m).
*Optional Jib Extension	60 ft. (18m) or 88 ft. (27m) fixed offset jib. Also available are 60 ft. and 88 ft. power luffing jibs. Maximum tip height: 270 ft. (82m).
Boom Nose	Eight sheaves mounted on heavy duty tapered roller bearings with removable pin-type rope guards. Standard removable auxiliary boom nose with removable pin type rope guard.
Boom Elevation	Dual double acting hydraulic cylinders with integral holding valve provides elevation from -3° to 80°.
Load Moment & Anti-Two Block System w/LMI	Audio-visual (light/buzzer) warning system and control lever lockout with electronic display of: boom angle, length, radius, boom tip height, relative load moment, rated load and actual load indication.
Cab	Full vision, all steel fabricated with acoustical lining and tinted safety glass throughout. Dash panel incorporates gauges for all engine functions. Other standard features include: hinged skylight, sliding left side door and sliding right side window, electric windshield wash-wipe, circulating air fan, heater and defroster, swing horn, fire extinguisher, seat belt. *Optional items: electric skylight wiper and air conditioning.
Swing	Roller bearing swing circle with 360° continuous rotation. Grove planetary "glide swing" with foot actuated disc brake, spring applied hydraulically released park brake and 360° position positive turntable lock. Combination controls provided for hand or foot operation. Swing speed 1.9 RPM.

Counterweight

Turntable mounted, power installed and removed, hydraulically extended to working position and retracted to stowed or travel position. 15,700 lbs. (7122 kg) with aux. hoist;

Engine	GM8.2L eight cylinder turbo-charged water cooled diesel. 500 cu. in. (8.2 L), 205 hp (153 kw) (Gross) @ 3000 RPM. Maximum net torque: 383 ft. lbs. (53 kg/m) @ 1700 RPM.
---------------	--

HYDRAULIC SYSTEM

Pumps	Six main gear pumps powered by superstructure engine. Manual pump disconnect. Combined capacity 349 GPM (1321 lpm).
Valves	Precision four way double acting control valves, 6 individual valve banks permit simultaneous control of multiple crane functions.
Filter	Return line type, full flow with by-pass protection and filter by-pass indicator, replaceable cartridge, 25 micron filtration rating.
Reservoir	420 gallons (1590 L) with spin-on breather filter, external sight gauge, clean out access, strap mounted to frame.
Oil Cooler	Full flow, fin and tube, oil to air.

HOIST SPECIFICATIONS

Series parallel circuitry and two motors provide both high line pull and speed ranges. Power up and down, equal speed, planetary reduction with integral automatic brake and electronic hoist drum rotation indicator.

	Make/Model	Main Hoist Germatic Model 44-26(H) and Grove Aux. Hoist H030B-26(H)	
		Main	Auxiliary
Maximum single line speed	Bottom layer	314 FPM (96m/min)	454 FPM (138m/min)
	Intermediate layer	366 FPM (112m/min)	528 FPM (161m/min)
	Top layer	419 FPM (128m/min)	601 FPM (183m/min)
Maximum single line pull	Bottom layer	24,900 lbs. (11295 kg)	16,322 lbs. (7404 kg)
	Intermediate layer	21,327 lbs. (9674 kg)	14,056 lbs. (6376 kg)
	Top layer	18,650 lbs. (8460 kg)	12,344 lbs. (5599 kg)
Maximum permissible line pull w/5:1 strength factor		22,760 lbs. (10324 kg)	12,920 lbs. (5,861 kg)
Maximum rope stowage	950 ft. of 1" dia. rope (290m of 25.4mm)	830 ft. of 3/4" dia. rope (253m of 19.1mm)	

†Patented Grove feature or patent pending.
*Denotes optional equipment.

BOOM

46 FT. TO 173 FT. AERIAL POWER PINNED BOOM CAPACITIES ON OUTRIGGERS FULLY EXTENDED - 360°

Radius in Feet	Main Boom Length in Feet (Power Pinned Ry Retracted)									Power Pin. Ry Ext. & 141 ft.	
	46	58	70	82	94	106	118	130	141		
10	300,000 (74.5)										
12	280,000 (72)	143,500 (76)	142,000 (79)								
15	235,000 (67.5)	143,500 (72.5)	141,500 (76.5)	130,000 (78.5)							
20	173,500 (60.5)	143,500 (67.5)	123,500 (72)	112,000 (75)	102,000 (77.5)	90,300 (79.5)					
25	135,500 (52)	131,500 (61.5)	110,500 (67.5)	98,650 (71)	89,250 (74)	78,550 (76.5)	73,700 (78.5)	69,300 (80)			
30	106,000 (43)	106,000 (55.5)	98,000 (63)	88,350 (67.5)	78,750 (71)	69,250 (73.5)	65,100 (76)	61,000 (77.5)	60,000 (79.5)		
35	84,700 (30.5)	84,700 (49)	84,700 (58)	80,150 (63.5)	69,000 (67.5)	60,750 (70.5)	57,150 (73)	54,000 (75.5)	52,150 (77.5)		
40		70,500 (41)	70,500 (52.5)	70,500 (59.5)	61,300 (64)	54,000 (67.5)	50,600 (70.5)	48,300 (73)	45,850 (75)	38,000 (79)	
45		57,250 (32)	57,250 (47)	57,250 (55)	55,000 (60.5)	48,500 (64.5)	45,200 (68)	43,050 (71)	40,400 (73)	35,750 (77)	
50		46,550 (17.5)	46,550 (40.5)	46,550 (50.5)	46,550 (57)	43,050 (61.5)	40,700 (65)	38,250 (68.5)	35,750 (71)	32,100 (75.5)	
60			32,000 (22.5)	32,000 (39.5)	32,000 (48.5)	32,000 (55)	32,000 (59.5)	30,750 (63.5)	28,500 (66.5)	26,350 (72)	
70				22,550 (25)	22,550 (39.5)	22,550 (47.5)	22,550 (53)	22,550 (58)	22,550 (61.5)	22,000 (68.5)	
80					15,900 (27)	15,900 (39)	15,900 (46.5)	15,900 (52.5)	15,900 (56.5)	18,500 (64.5)	
90						11,000 (28)	11,000 (38.5)	11,000 (46.5)	11,000 (51.5)	15,250 (60.5)	
100							7,260 (29)	7,260 (39)	7,260 (45.5)	11,750 (56.5)	
110								4,260 (12.5)	4,260 (30.5)	4,260 (39)	8,520 (52)
120									1,830 (17.5)	1,830 (31)	5,850 (47.5)
130											3,610 (42.5)
140											1,710 (36.5)
Minimum boom angle (deg.) for indicated length (no load)										20	30
Maximum boom length (ft.) at 0 deg. boom angle (no load)										133	156

NOTE: Boom angles are in degrees.

A6-829-007136 & -007143

CAPACITIES FOR 33 FT. FIXED LENGTH EXTENSION ON OUTRIGGERS - 360°

Main Boom Angle (Deg.)	2° OFFSET		15° OFFSET		30° OFFSET	
	Rad. Ref. (ft.)	Cap. lbs.	Rad. Ref. (ft.)	Cap. lbs.	Rad. Ref. (ft.)	Cap. lbs.
80	39.1	22,850	45.9	20,200	52.0	14,750
75	56.6	17,400	63.0	16,100	68.7	12,750
70	73.7	14,000	79.6	12,950	84.8	10,700
65	90.2	11,850	95.5	10,750	100.3	9,210
60	106.0	10,750	110.8	9,140	115.0	8,050
55	121.1	7,240	125.2	6,160	128.8	5,320
50	135.2	4,330	138.6	3,700	141.8	3,150

A6-829-008157

DIMENSIONS ARE FOR LARGEST GROVE FURNISHED HOOK BLOCK AND HEADACHE BALL WITH ANTI-TWO BLOCK ACTIVATED.

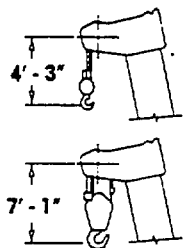

CAPACITIES FOR 33 FT. - 58 FT. TELE. EXTENSION ON OUTRIGGERS - 360°

Main Boom Angle (Deg.)	33 ft. EXTENSION						48 ft. EXTENSION						58 ft. EXTENSION					
	2° OFFSET		15° OFFSET		30° OFFSET		2° OFFSET		15° OFFSET		30° OFFSET		2° OFFSET		15° OFFSET		30° OFFSET	
	Rad. Ref. ft.	Cap. lbs.	Rad. Ref. ft.	Cap. lbs.	Rad. Ref. ft.	Cap. lbs.	Rad. Ref. ft.	Cap. lbs.	Rad. Ref. ft.	Cap. lbs.	Rad. Ref. ft.	Cap. lbs.	Rad. Ref. ft.	Cap. lbs.	Rad. Ref. ft.	Cap. lbs.	Rad. Ref. ft.	Cap. lbs.
80	39.1	22,300	45.9	19,650	52.0	14,200	43.9	14,800	55.9	12,700	65.0	9,040	45.1	9,600	59.1	8,300	69.6	7,000
75	56.6	16,850	63.0	15,550	68.7	12,200	62.5	13,700	73.4	10,900	81.8	8,320	65.0	9,150	77.9	7,950	87.8	6,440
70	73.7	13,450	79.6	12,400	84.8	10,150	80.7	11,600	90.3	8,840	97.9	7,110	84.4	8,550	96.2	7,200	105.5	5,760
65	90.2	11,300	95.5	10,200	100.3	8,670	98.2	9,230	106.7	7,330	113.3	6,120	103.2	7,630	113.8	6,000	122.3	4,970
60	106.0	10,200	110.8	8,600	115.0	7,450	115.1	7,550	122.1	6,210	127.9	5,340	121.2	6,260	130.5	5,100	138.2	4,360
55	121.1	6,440	125.2	5,370	128.8	4,540	131.1	5,200	136.7	3,860	141.5	2,950	138.2	4,650	146.2	3,265	153.1	2,380
50	135.2	3,520	138.6	2,910	141.8	2,360	146.1	2,580	150.2	1,790			154.3	2,235				

A6-829-007158

CAPACITIES FOR 46 FT. - 88 FT. FIXED OFFSET JIBS ON OUTRIGGERS - 360°

Main Boom Angle (Deg.)	46 FT. JIB						60 FT. JIB					
	5° OFFSET		17° OFFSET		30° OFFSET		5° OFFSET		17° OFFSET		30° OFFSET	
	Rad. Ref. (ft.)*	Cap. lbs.**	Rad. Ref. (ft.)	Cap. lbs.	Rad. Ref. (ft.)	Cap. lbs.	Rad. Ref. (ft.)	Cap. lbs.	Rad. Ref. (ft.)	Cap. lbs.	Rad. Ref. (ft.)	Cap. lbs.
80	44.4	14,900	52.4	12,600	59.8	8,120	47.1	12,500	58.6	8,530	68.7	5,350
77.5	53.7	14,450	61.6	11,650	68.8	7,750	57.1	11,650	68.2	7,850	78.1	5,070
75	62.9	14,000	70.6	10,850	77.6	7,410	67.0	10,800	77.9	7,260	87.3	4,830
72.5	72.0	13,600	79.5	10,150	86.2	7,120	76.8	10,000	87.2	6,760	96.5	4,610
70	81.0	12,470	88.3	9,550	94.8	6,860	86.5	9,230	96.5	6,330	105.3	4,420
67.5	89.8	11,250	96.9	8,980	103.2	6,630	96.0	8,500	105.6	5,950	114.2	4,250
65	98.4	8,850	105.3	7,940	113.2	6,430	105.2	7,850	114.5	5,620	122.7	4,100
62.5	106.9	6,900	113.5	6,550	119.2	6,210	114.3	6,430	123.2	5,270	130.9	3,970
60	115.1	5,370	121.5	5,080	126.9	4,800	123.2	5,010	131.6	4,500	138.9	3,850
55	131.0	3,050	136.8	2,870	141.6	2,700	140.2	2,980	147.7	2,670	154.1	2,370
50	145.9	1,550	151.1	1,460	155.2	1,370	156.2	1,430	162.7	1,260	168.2	1,100

Main Boom Angle (Deg.)	74 FT. JIB						88 FT. JIB					
	5° OFFSET		17° OFFSET		30° OFFSET		5° OFFSET		17° OFFSET		30° OFFSET	
	Rad. Ref. (ft.)	Cap. lbs.	Rad. Ref. (ft.)	Cap. lbs.	Rad. Ref. (ft.)	Cap. lbs.	Rad. Ref. (ft.)*	Cap. lbs.**	Rad. Ref. (ft.)	Cap. lbs.	Rad. Ref. (ft.)	Cap. lbs.
80	50.8	9,470	64.3	6,000	78.0	3,530	52.9	7,300	70.1	3,970	86.0	2,330
77.5	61.2	8,790	74.6	5,470	87.8	3,310	64.1	6,580	80.9	3,590	96.2	2,060
75	71.6	7,980	84.7	5,020	97.3	3,120	75.2	5,950	91.5	3,260	106.3	1,820
72.5	81.9	7,280	94.7	4,630	106.8	2,950	86.1	5,380	102.0	2,980	116.2	1,610
70	92.0	6,610	104.3	4,290	116.0	2,800	96.9	4,800	112.2	2,740	126.0	1,450
67.5	101.9	6,030	114.0	4,000	124.9	2,660	107.5	4,300	122.2	2,530	135.3	1,330
65	111.6	5,500	123.3	3,740	133.7	2,540	117.9	3,870	132.1	2,340	144.6	1,220
62.5	121.1	5,040	132.5	3,510	142.1	2,440	128.0	3,510	141.7	2,180	153.5	1,150
60	130.2	4,050	141.2	3,260	150.2	2,350	138.0	2,870	150.9	1,970	162.1	1,080
55	148.1	2,020	158.2	1,810	165.8	1,600						

*Reference radius refers to fully extended boom and appropriate jib length.

**Capacities at loaded main boom angle.

NOTE: Jib lifting capacities with auxiliary hoist only (3/4 in. wire rope).

A6-829-007220

WEIGHT REDUCTIONS FOR LOAD HANDLING DEVICES

46 ft. - 173 ft. Boom with	
*46 ft. Jib Erected -	9,613 lbs.
*60 ft. Jib Erected -	14,571 lbs.
*74 ft. Jib Erected -	20,443 lbs.
*88 ft. Jib Erected -	27,199 lbs.

*Reduction of main boom capacities

HOOKBLOCKS:	
30 Ton, 1 Sheave	1,022 lbs.
150 Ton, 8 Sheave	5,254 lbs.
Auxiliary Boom Head	261 lbs.
10 Ton Headache Ball	560 lbs.
15 Ton Headache Ball	803 lbs.

NOTES FOR LIFTING CAPACITIES

1. All capacities above the bold line are based on structural strength of jib.
2. 46', 60', 74' & 88' jibs may be used for two-part line lifting crane service only.
3. **WARNING:** Operation of this machine with heavier loads than the capacities listed is strictly prohibited. Machine tipping with boom extension occurs rapidly and without advance warning.
4. Rated load is based on loaded main boom angle with reference to horizontal, regardless of main boom length. (Ref. radius in ft. is for fully extended boom and power pinned fly extended 173 ft. boom length only.)
5. Capacities listed are with fully extended outriggers and front jack cylinder extended according to proper procedure.
6. **46 FT. JIB WARNING:** With 46 ft. jib in working position, the boom angle must not be less than 50° since loss of stability will occur causing a tipping condition.
60 FT. JIB WARNING: With 60 ft. jib in working position, the boom angle must not be less than 50° since loss of stability will occur causing a tipping condition.
74 FT. JIB WARNING: With 74 ft. jib in working position, the boom angle must not be less than 55° since loss of stability will occur causing a tipping condition.
88 FT. JIB WARNING: With 88 ft. jib in working position, the boom angle must not be less than 60° since loss of stability will occur causing a tipping condition.
7. **JIB ERECTION NOTES:**
 - A. Maximum total length of main boom for purpose of erecting jib, over rear or side, below 30° main boom angle is:
 - 46 ft. Jib - 136 ft.
 - 60 ft. Jib - 129 ft.
 - 74 ft. Jib - 122 ft.
 - 88 ft. Jib - 115 ft.
 - B. **WARNING:** Do not attempt to erect jib over front of machine, unless boom is fully retracted (power pinned fly extended).

"WARNING: THIS CHART IS ONLY A GUIDE. The Notes below are for illustration only and should not be relied upon to operate the crane. The individual crane's load chart, operating instructions and other instruction plates must be read and understood prior to operating the crane."

1. All rated loads have been tested to and meet minimum requirements of SAE J1063 OCT80 - Cantilevered Boom Crane Structures - Method of Test, and do not exceed 85% of the tipping load on outriggers as determined by SAE J765 OCT80 Crane Stability Test Code.
2. Capacities given do not include the weight of hookblocks, slings, auxiliary lifting equipment and load handling devices. Their weights **MUST** be added to the load to be lifted. When more than minimum required reeving is used, the additional rope weight shall be considered part of the load.
3. Capacities appearing above the bold line are based on structural strength and tipping should not be relied upon as a capacity limitation.
4. All capacities are for crane on firm, level surface. It may be necessary to have structural supports under the outrigger floats or tires to spread the load to a larger bearing surface.
5. When either boom length or radius or both are between values listed, the smallest load shown at either the next larger radius or boom length shall be used.
6. For outrigger operation, ALL outriggers shall be fully extended with tires raised free of ground before raising the boom or lifting loads.
7. Unless otherwise stated, capacities are with powered boom sections equally extended.

Constant improvement and engineering progress makes it necessary that we reserve the right to make specification, equipment, and price changes without notice. Illustrations shown may include optional equipment and accessories and may not include all standard equipment.

North and South America, U.S.S.R., Far East, Australasia

GROVE MANUFACTURING COMPANY

Box 21 ■ Shady Grove ■ Pennsylvania 17256
(717) 597-8121 ■ telex: 842308 ■ fax: (717) 597-4062

Europe, Africa, Middle East, Indian Sub-continent

GROVE

Sunderland ■ SR4 6TT ■ England
(091) 565 6281 ■ telex: 53506 CRANES G ■ fax: (091) 564 0442

FORM NO.: LCTM1500P. 1289-5M-FB PRINTED IN U.S.A.