



# SPECIFICATION BOOK

(Price List Enclosed)

Product Descriptions Beginning 1/1/12

## MAGNATRAC® Hydro Crawlers

### MH8000

**MAGNATRAC® 8000** - Assembled. Includes 31 HP Briggs & Stratton Vanguard Commercial Engine. "V" twin cylinder air-cooled gasoline engine with overhead valves, electric starting, 20 amp alternator, full pressure lubrication, and 5" centrifugal multi-stage air cleaner. Dual pump hydraulic system with "expandable" Attachment Control valve. Track Shoes **not** included - see Track Shoe Kits (page 2). Dual halogen lights and Basic Five Bank Control Valve. [NOTE: 35 HP Briggs & Stratton Vanguard Engine Upgrade available... ENG35 - 35HP Engine Upgrade, page 2.]

MH8000 - Magnatrac Hydro ..... 2100 lbs.



### MH4800

**MAGNATRAC® 4800** - Assembled. Includes 25 HP Kohler "V" twin cylinder gasoline engine with overhead valves, electric starting, and 15 amp alternator. Single pump hydraulic system with "expandable" Attachment Control Valve. Track Shoes **not** included - see Track Shoe Kits (page 2). Includes Basic Four Bank Control Valve.

MH4800 - Magnatrac Hydro ..... 1685 lbs.



**MH4800**

**IMPORTANT:** Though the MAGNATRAC 4800, and 8000 are offered completely assembled, it's still the customer's responsibility to provide competent service ability! The servicing can be provided either by the mechanically inclined customer, or by a local mechanic. All Attachments and Accessories are shipped in an easy-to-assemble "semi-kit" form for lowest cost shipping. We provide manuals & illustrations for complete service and repair so that anyone with reasonable mechanical skill can perform all required service work. Check the MAGNATRAC Specifications & Ratings (pg. 3) for a list of all standard features.

# MAGNATRAC® Accessories



## ENG35 35HP Engine Upgrade Package

35 HP Engine Upgrade Package provides maximum workpower! It also boasts full pressure lubrication, cast iron cylinder sleeves, commercial grade starter, 20 amp alternator and a 5" Donaldson multistage air cleaner. [MH8000 only]

ENG35 35HP Engine Upgrade



## MS32 Mud Scrapers Kit

Replaces standard track covers with heavy-duty covers incorporating 1" thick solid steel bars to prevent mud and ice build-up between track sprockets.

MS32 Mud Scrapers Kit . . . . . 85 lbs.

## ROPS80 Roll-Over Protective Structure Kit

**\*\* According to Federal Laws, no tractor can be operated by employees without a Roll-Over Protective Structure!**

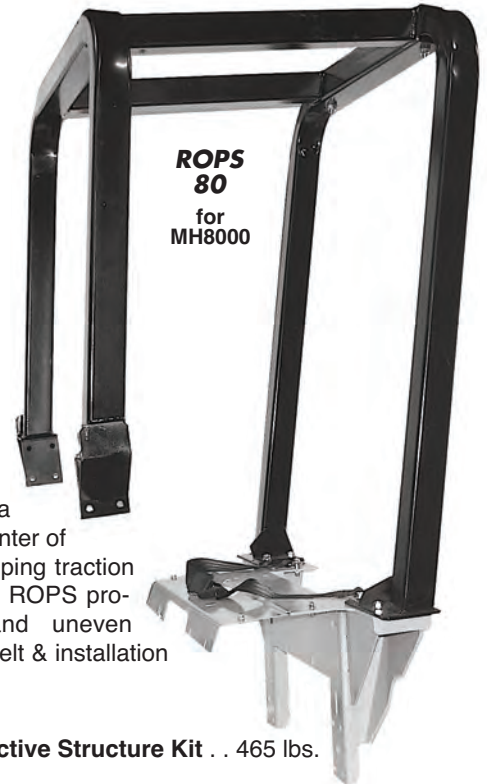

Safety-First! Even a Struck Crawler's low center of gravity and ground-gripping traction are not a substitute for ROPS protection on slopes and uneven ground. Includes seat belt & installation hardware.

ROPS80 Roll-Over Protective Structure Kit . . 465 lbs.



For operator safety, a ROLL-OVER PROTECTIVE STRUCTURE is strongly recommended for all MAGNATRACS!

**NOTE:** Though Track Shoes are **strongly recommended**, and provide greatest traction and stiffen Track Pads for working in rock, Magnatracs not so equipped will still pull about 80% of crawler's rated drawbar ability.

## TSO40 Steel Grouser Track Shoe Kit

Replaceable, channel-shaped Steel Grouser Shoes provide the ultimate in traction. These all-steel shoes will go through mud and bite into the hardest ground for maximum traction. [Factory assembly available]

TSO40 Steel Grouser Track Shoe Kit . . . . . 75 lbs.

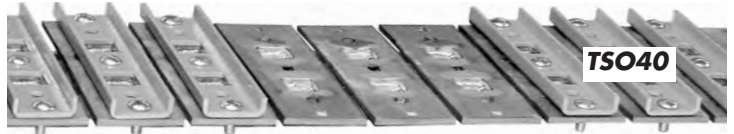

## TSO45P Non-Marking Track Shoe Kit



Made of 3/4" thick blocks of UHMW Polyethylene encased in all-steel jackets, Non-Marking Track Shoes give you traction in soft going while protecting concrete and asphalt. [Factory assembly available] **NOT RECOMMENDED FOR USE ON ICE & SNOW.**

TSO45P Non-Marking Track Shoe Kit . . . . . 118 lbs.

## TK551X Track Set Kit

Set of Original Equipment Tracks (only one shown). Rated 40,000 ultimate strength per Track. Buy a second set of Tracks for complete versatility. Today you need the tough bite of Grouser Shoes, next week the forgiving touch of Non-Marking Shoes. Switch Tracks, not Shoes!

TK551X Track Set Kit (pair) . . . . . 220 lbs.



# Specifications & Ratings

## MH4800

## MH8000

<b>Engine</b>	25 HP Kohler Command, "V" twin cylinders [Gasoline]	31 HP Briggs & Stratton Vanguard, "V" twin cylinders [Gasoline] <i>[35HP Engine Upgrade <b>ENG35</b> available; see page 2]</i>
<b>Air Cleaner</b>	Paper element, oiled foam precleaner	5" Donaldson cyclonic multi-stage
<b>Track Drive Pump</b>	0.775 cubic inch displacement, 12.08 GPM at 3600 RPM	1.01 cubic inch displacement, 15.7 GPM at 3600 RPM
<b>Attachment Pump</b>	Not available	0.500 cubic inch displacement, 7.8 GPM @ 3600 RPM
<b>Gas Tank</b>	Remote with fuel pump, 4.5 gal. capacity	Remote with fuel pump, 5 gal. capacity
<b>Hydraulic Oil Cooler</b>	Internally mounted, engine fan cooled (optional electric booster fan available). Cooling Core Area - 126 sq. in.	Externally mounted, 16" engine fan cooled, Cooling Core Area -190 sq. in.
<b>Attachment Valve</b>	Expandable Four (4) sectional valve	Expandable Five (5) section valve Regular Drive: 15.7 GPM @ 3000 PSI Overdrive: 23.5 GPM @ 3000 PSI
<b>Track Motors</b>	10.6 cubic inch displacement, rated at over 3500 PSI	10.6 cubic inch displacement, rated at over 3500 PSI
<b>Travel Speed</b>	Regular Drive.....1.82 MPH Overdrive ..... not available	Regular Drive..... 2.4 MPH Overdrive ..... 3.5 MPH
<b>Instrumentation</b>	Hydraulic oil temp. amp & hour gauges	Hydraulic oil temp. amp & hour gauges
<b>Chain Sprockets</b>	Induction hardened steel	Induction hardened steel
<b>Track Sprockets</b>	AR200 pre-hardened steel, plasma cut	AR200 pre-hardened steel, plasma cut
<b>Track Rollers</b>	4-1/2" diameter, 5/8" thick flanges, Solid steel (3) per side	4-1/2" diameter, 5/8" thick flanges, Solid steel (5) per side
<b>Track Chain</b>	Double lengths #551X Chain, 40,000 ultimate strength per Track	Double lengths #551X Chain, 40,000 ultimate strength per Track
<b>Track Shoes</b>	9-1/2" wide, 7/16" diameter overall laminated thickness, Grouser and Non-Marking options	9-1/2" wide, 7/16" diameter overall laminated thickness, Grouser and Non-Marking options
<b>Primary Drive Chain</b>	50H 7,800 lbs. tensile strength	60R 9,200 lbs. tensile strength
<b>Final Drive Chain</b>	80HK, 22,046 lbs. tensile strength	80HK, 22,046 lbs. tensile strength
<b>Axle Diameters</b>	7/8" dia. on Idlers; 1-3/16" diameter on Track Sprockets	7/8" dia. on Idlers; 1-3/16" diameter on Track Sprockets
<b>Park &amp; Emgr. Brake</b>	Dual 8" diameter disk type	Dual 8" diameter disk type
<b>Battery</b>	295 CCA	750 CCA
<b>Weight (no attach's)</b>	1685 lbs.	2100 lbs.
<b>Track Tensioning</b>	Industrial grade coiled steel springs (4)	Industrial grade coiled steel springs (4)
<b>Track Ground Contact</b>	5.36 sq. ft.	5.36 sq. ft.
<b>Overdrive</b>	Not Available	Continuous Use
<b>Seat</b>	Low Back, Rotatable, multiple height settings with Pin.	High Back, Rotatable, multiple height settings with Pin
<b>HC74 Hydro Circuit</b>	Optional	Included

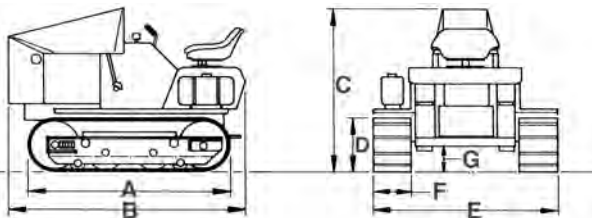

	<b>Tractor Dimensions</b>						
	<b>A</b>	<b>B</b>	<b>C</b>	<b>D</b>	<b>E</b>	<b>F</b>	<b>G</b>
<b>4800</b>	55-7/8"	57"	43"	15-1/8"	48-7/8"	9-1/2"	6"
<b>8000</b>	55-7/8"	62-1/2"	51"	15-1/8"	48-7/8"	9-1/2"	6"

C.F. STRUCK CORP. has a policy of continuous product improvement and reserves the right to change its products, specifications and dimensions at any time without notice or obligation. All dimensions and specifications are based upon best possible performance using the highest performance components available and running at 100% efficiency. Results will vary due to changes in size of engine and components, component wear, oil temperature, etc. If a particular specification or dimension is critical to your application contact the factory for more detailed information.

### PAYMENT TERMS

Payment in form of Cashier's Check, Money Order, Visa, Mastercard, Discover or Wire Transfer. 30% deposit required when placing order; payment in full & warranty acknowledgment required before shipment. Prices do not include transportation charges or any state or local taxes. Prices quoted are F.O.B. factory in Cedarburg, WI 53012. All Prices and Specifications are subject to change without notice or obligation.



# MAGNATAC® Attachment Kits



## EB460 Excavating Bucket Kit

48" wide x 15" high x 19" deep excavating bucket. Attaches with four Pins. Has bolt-on replaceable cutting edge. For tougher work add T10 Tooth Bar (see right).

EB460 Excavating Bucket Kit . . . 135 lbs.



## T10 Tooth Bar Kit

Bolt-on replaceable bar with 10 hardened "plow steel" teeth. Gives EB460 Excavating Bucket (see left) greater digging ability, and allows MB480 Material Bucket (see right) to break up packed material.

T10 Tooth Bar Kit . . . . . 15 lbs.



## MB480 Material Bucket Kit

48" wide X 19" high x 26" deep material bucket. Attaches with four Pins. Has bolt-on replaceable cutting edge. For tougher work add T10 Tooth Bar (see left).

MB480 Material Bucket Kit . . . . . 150 lbs.



## SB480S Material Bucket Kit

Heavy-Duty 48" wide x 19" high x 21" deep excavating bucket for use with SH44 Speed Hitch on HL900 Loader. Has beveled, heat-treated, "plow steel" cutting edge welded to bucket forward edge.

SB480S Bucket [Speed Hitch] . . . 170 lbs.  
SB480P Bucket [Pin Hitch] . . . . . 210 lbs.



## SB480TS Excavating Bucket Kit

Same heavy-duty bucket as SB480S Speed Bucket (at left), but with six professional-quality replaceable teeth made of special "abrasive resistant" cast steel.

SB480TS Bucket [Speed Hitch] . . . . . 200 lbs.  
SB480PT Bucket [Pin Hitch] . . . . . 240 lbs.



## DB480S Debris Bucket Kit

Heavy-duty 48" wide x 19" high x 21" deep stone and debris bucket. 1/2" thick steel sidewalls cut to form teeth that grip logs & brush. 1/2" steel rod bottom allows dirt and debris to fall through.

DB480S Bucket [Speed Hitch] . . . 200 lbs.  
DB480P Bucket [Pin Hitch] . . . . . 200 lbs.

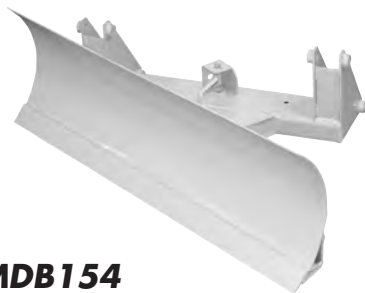

## MDB154 Angling Blade Kit

Mounts to Loader in place of Bucket. Loader's hydraulics control blade's lift. Adjust Blade's angle with single pin - no tools! [Add CK29 Cylinder Kit (below) for hydraulic angling]. Blade is 54" wide, 17" high and 3/16" thick.

MDB154 Angle Blade Kit . . . . . 230 lbs.

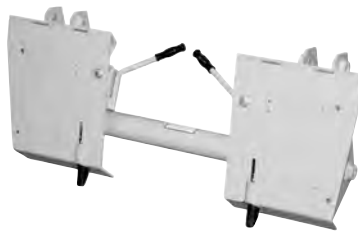

## SH44 Speed Hitch Kit

Universal Mounting Hitch allows HL900 Loader to utilize third party skid steer attachments including augers, tillers, trenchers, snow blowers, grapples, pallet forks, and many more. Check with attachment manufacturer for tractor requirements.

SH44 Speed Hitch Kit . . . . . 105 lbs.



## MDB154S Angling Blade Kit

Mounts to Loader equipped with SH44 Speed Hitch. Uses Loader's hydraulics to control blade's lift. Adjust blade angle with single pin - no tools required. [Add CK29 Cylinder Kit (below left) for hydraulic angling] Blade is 54" wide, 17" high and 3/16" thick.

MDB154S Angle Blade Kit . . . . . 250 lbs.



## CK29 Cylinder Kit

CK29 Cylinder Kit . . . . . 20 lbs.

**TR28S  
Tree  
&  
Rock  
Shovel  
Kit**



108 lbs. of solid steel plate pressed into a massive shovel. Mounts to Loader equipped with SH44 Speed Hitch. Scoops rocks and with its sharp teeth, tears out small trees & bushes with over 2000 lbs. of breakout force.

TR28S Tree/Rock Shovel Kit . . . . . 185 lbs.

**BG48  
Grapple  
Kit**



Mounts to DB480S, SB480TS, & SB480S Buckets (see page 4). Consists of four solid steel tines robotically welded to heavy-duty frame developing over 1,000 lbs of clamping force. Retracts completely to allow normal loader operations without removal. [Requires drilling (25) 3/8" holes in mating Bucket; Factory assembly available]

BG48 Grapple Kit . . . . . 145 lbs.

**HP22S Hitch Plate Kit**



Universal mounting plate for adapting attachments from other manufacturers to a SH44 Speed Hitch. Includes "keyhole" slots for attaching lift chains. Center hole provided for mounting HR2 Receiver Hitch for class II (2" square) ball mounts and related class II attachments. Specify painted or unpainted.

HP22S Hitch Plate Kit . . . . . 75 lbs.  
HR2 Hitch Receiver Kit (not shown) . . . . . 5 lbs.

**PF46S Pallet Fork Kit**

Heavy-duty pallet forks turn your HL900 Loader into a versatile forklift. Mounts to SH44 Speed Hitch in just seconds. (not shown)

PF46S Pallet Fork Kit . . . . . 425 lbs.

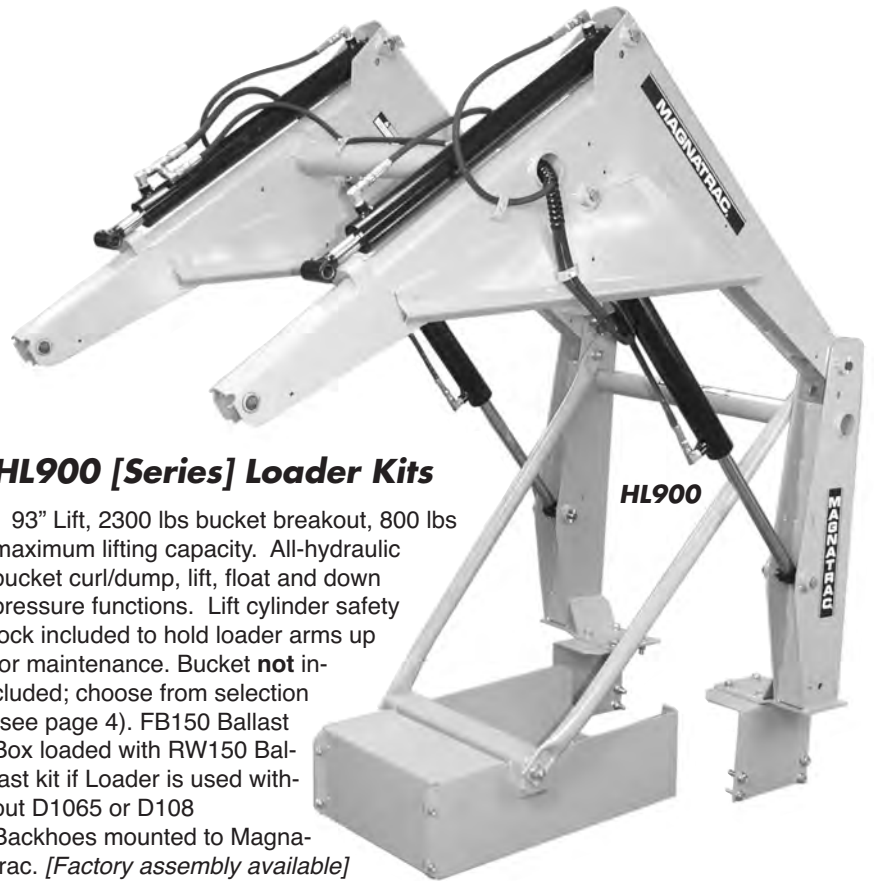

**HL900 [Series] Loader Kits**

93" Lift, 2300 lbs bucket breakout, 800 lbs maximum lifting capacity. All-hydraulic bucket curl/dump, lift, float and down pressure functions. Lift cylinder safety lock included to hold loader arms up for maintenance. Bucket **not** included; choose from selection (see page 4). FB150 Ballast Box loaded with RW150 Ballast kit if Loader is used without D1065 or D108 Backhoes mounted to Magnatrac. [Factory assembly available]

- HL900 Loader Kit [for MH4800] . . . . . 570 lbs.
- HL950 Loader Kit [for MH8000 with ROPS80] . . . . . 465 lbs.
- HL975 Loader Kit [for MH8000 without ROPS80] . . . . . 572 lbs.

**FB150 [Series] Ballast Box Kits**

Required rear counterweight when using HL900 [Series] Loader as independent attachment. Specify FB150IM Independent (shown at right) or FB150RM Rear Hitch mounting style. FB150 Ballast Box not required if HL900 Loader and D1065 or D108 Backhoe are mounted simultaneously. **Does not** include steel ballast - order RW150.

- FB150 Ballast Box Kit . . . . . 102 lbs.
- RW150 Ballast Kit . . . . . 850 lbs.

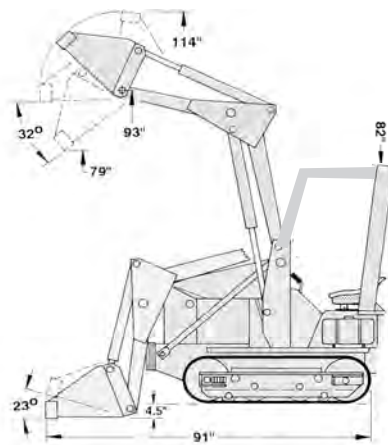
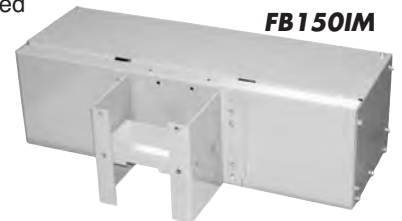

LOADER SPECIFICATIONS	
<b>LIFT CAPACITY</b> (to full height)	
HL900 . . . . .	800 lbs
<b>BREAKOUT CAPACITY</b> (arms)	
HL900 . . . . .	2000 lbs
<b>BREAKOUT CAPACITY</b> (bucket)	
HL900 . . . . .	2300 lbs
<b>Bucket Capacity</b> (heaped)	
MB480 . . . . .	9.5 cu. ft.
EB460 . . . . .	5.9 cu. ft.
SB480S . . . . .	8.0 cu. ft.

# MAGNATRAC® Attachment Kits

## D108 Backhoe Kit

Eight foot digging depth, 164° swing arc. Complete with cylinders, hoses, fittings, and six section hydraulic valve. Does **not** include "Wobble Controls", Bucket or Grapple. (See WC10 Wobble Controls [right], B808, B816, & B824 Buckets and GB15 Grapple [below].

HL900 [Series] Loader (loaded with FW20 Ballast Kit) or equivalent counterweight must be mounted to front of Magnatrac for proper balance. *[Factory assembly available]*

D108 Backhoe Kit . . . . . 865 lbs.  
FW20 Ballast Kit . . . 625 lbs.

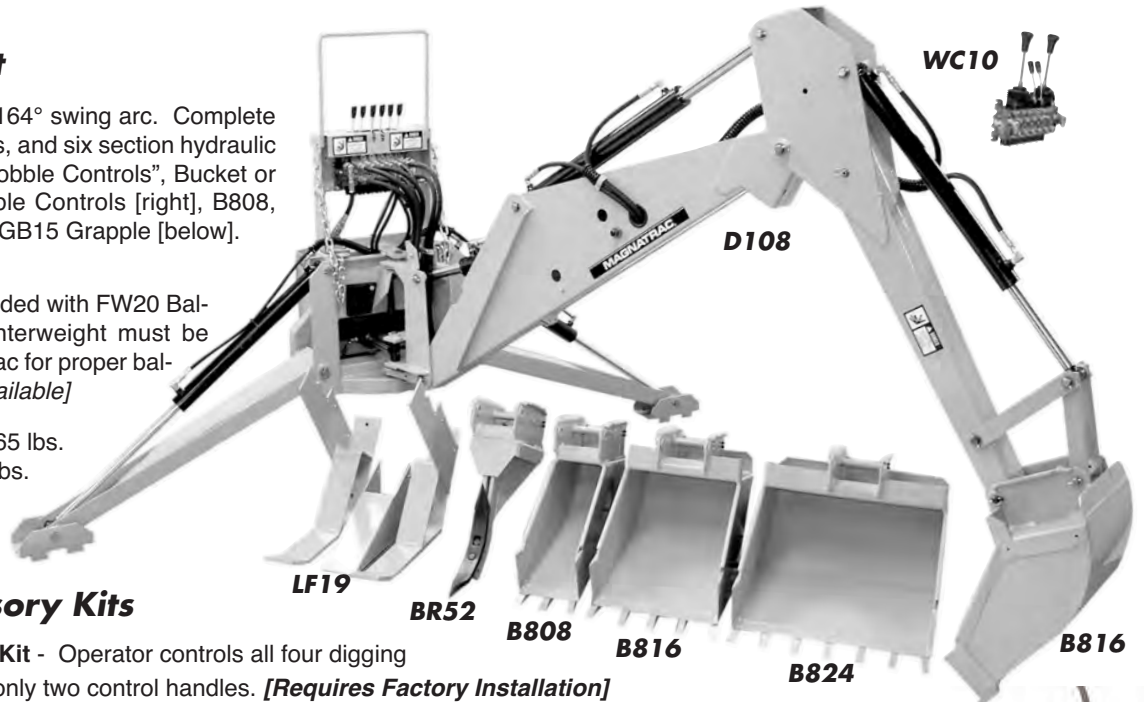

## D108 Backhoe Buckets & Accessory Kits

- WC10 **Wobble Controls Kit** - Operator controls all four digging operations with only two control handles. *[Requires Factory Installation]*
- B808 **8" Bucket Kit** - Eight inch digging width . . . . . 55 lbs.
- B816 **16" Bucket Kit** - Sixteen inch digging width . . . . . 75 lbs.
- B824 **24" Bucket Kit** - Twenty-four inch digging width . . . . . 95 lbs.
- LF19 **Log Fork Kit** - Two "forks" that bolt to interior of B816 or B824 Buckets (above) and an adjustable "thumb" mounted to the Backhoe's dipper. *[Requires drilling ten 1/2" holes in Bucket.]* . . . . . 85 lbs.
- BR52 **Frost / Chisel Tooth Ripper Kit** - Heavy-duty single tooth ripper with two replaceable teeth: (1) 16" x 2" x 1/2" thick "plow steel" tooth for stone & frost picking & hardpan penetration to 18"; the other 15" x 2" x 1/2" thick tooth, allows root cutting to depths of 18". Mounts in place of Bucket on Backhoe Dipper. . . . . 35 lbs.
- GB15 **Backhoe Grapple** - Self-leveling grapple that produces over 1,000 lbs. of clamping force. Attaches to Backhoe in place of standard Bucket. Complete with Cylinder, Fittings & Hoses . . . . . 125 lbs.

## SWB54 Six-Way Blade Kit

Extra heavy-duty, fully reinforced 54" wide x 22" high x 1/4" thick solid steel blade with 3/4" thick x 4" wide heat-treated "plow steel" cutting edge. Mounts directly to track frame. Complete with lift, tilt, and angle cylinders, hoses, fittings, mounting hardware. Features an extra heavy-duty front hitch system with total control of : lift, float, down-pressure, 25°left & 25° right angling and 9° of tilt above and 9° below horizon. NOT to be used with a HL900 [Series] Loader or D108 Backhoe in place. (Use MDB154 or MDB154S Angling Blade Kits for "dozing" in Loader applications) *[Factory assembly available]*

SWB54 Six-way Blade Kit . . . . . 525 lbs.

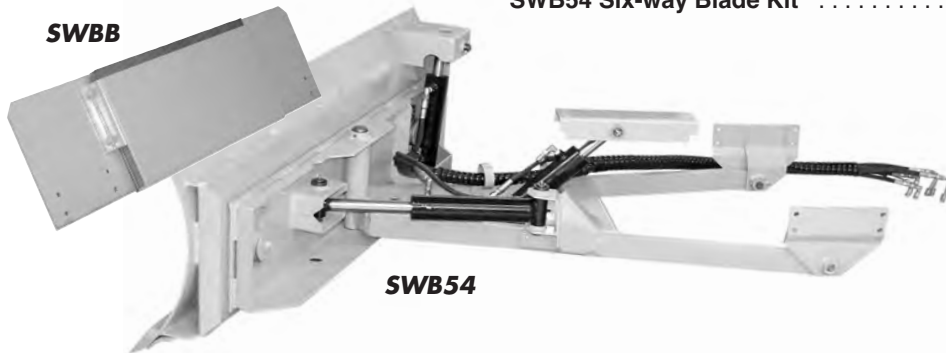

**SIX-WAY BLADE SPEC'S**

BLADE WIDTH . . . . . 54"  
TILT ANGLE (above/below horizon) . . . . . 9°  
BLADE ANGLE (left/right) . . . . . 25°  
LIFT (above/below grade) . . . . . 8-1/2" / 4"  
LIFT FORCE (at cutting edge) . . . . . 255 lbs

## SWBB Blade Extension & Weight Box

Blade extension increases blade height capacity by 9"; perfect for dozing bark chips, grain, snow, etc. Weight Box and **included** steel "ballast" increases Blade's down pressure by 221 lbs. **SWBB Blade Extension / Weight Box Kit** . . . . . 221 lbs.



# MAGNATRAC® Attachment Kits

## D1065 [Series] Backhoe Kits

80" digging depth, 120° swing arc. Complete with cylinders, hoses, fittings, and six section hydraulic valve. Does **not** include "Wobble Controls" or Bucket (see WC10 Wobble Controls & B612 Bucket below). [Factory assembly available]

HL900 [Series] Loader (loaded with FW20 Ballast Kit), SWB54 Six-Way Blade (with SWBB Blade Extension & Weight Box), or equivalent counterweight must be mounted to front of Magnatrak for proper balance.

D1065IM Backhoe Kit [Independent Mount] ..... 455 lbs.  
 D1065RM Backhoe Kit [3 Point Mount] ..... 455 lbs.

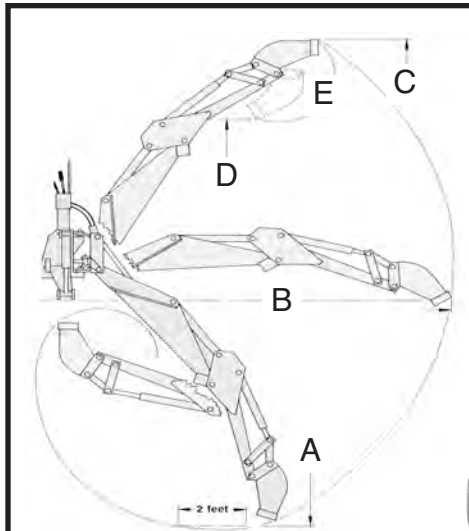

### BACKHOE DIMENSIONS

	A	B	C	D	E
D1065	80"	114"	103"	75"	162"
D108	99"	140"	118"	85"	200"

### BACKHOE RATINGS

	D1065	D108
BUCKET FORCE	2500 lbs	3200 lbs
DIPPER FORCE	1250 lbs	2250 lbs
LIFT (@ bucket pivot)	135 lbs	250 lbs
LIFT (@ dipper pivot)	210 lbs	400 lbs
SWING ARC	120°	164°
STABILIZER SPREAD	41-1/2"	119"
TRANSPORT WIDTH	41-1/2"	48-1/2"
BUCKET CAPACITIES		
B808	-	0.67 cu. ft.
B612	1.16 cu. ft.	-
B816	-	1.54 cu. ft.
B824	-	2.51 cu. ft.

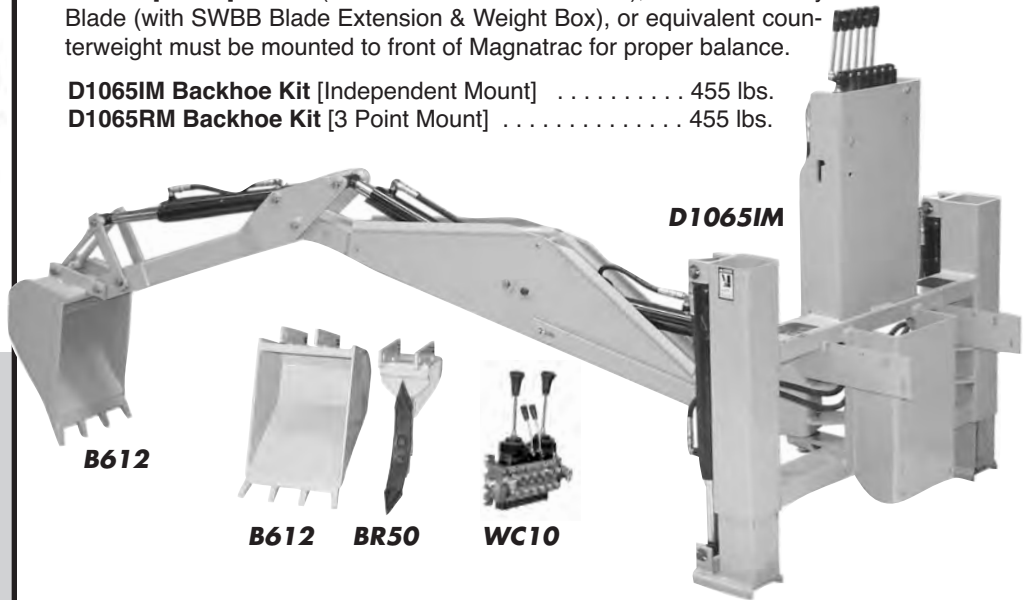

## D1065 [Series] Backhoe Buckets & Accessory Kits

**WC10 Wobble Controls Kit** - Allows operator to control all four digging operations with only two control handles. [MUST BE FACTORY INSTALLED]

**B612 12" Bucket Kit** - Twelve inch digging width ..... 40 lbs.

**BR50 Frost / Chisel Tooth Ripper Kit** - Heavy-duty single tooth ripper with two replaceable teeth: (1) 16" x 2" x 1/2" thick "plow steel" tooth for stone & frost picking & hardpan penetration to 18"; the other 15" x 2" x 1/2" thick serrated edge tooth allows root cutting to depths of 18". Mounts in place of Bucket on Backhoe. .... 25 lbs.

**RT24 Rock/Debris Thumb Kit** [not shown] ..... 35 lbs.

## RH65 Rear Hitch Kit

Full sized, all-hydraulic, three point Category #1 Rear Hitch providing "lift, float, and down pressure" to both lift arms. Check with factory for proper front counterweighting. Does **not** include PTO70 Power Takeoff (see next page). Includes cylinder safety lock to hold hitch "up" when disconnecting hydraulic source. Develops 1000 lbs. Lift. (Requires HL900 Series Loader or equivalent counterweight mounted to front of Magnatrak for proper balance) [Factory assembly available]

RH65 Rear Hitch Kit ..... 240 lbs.

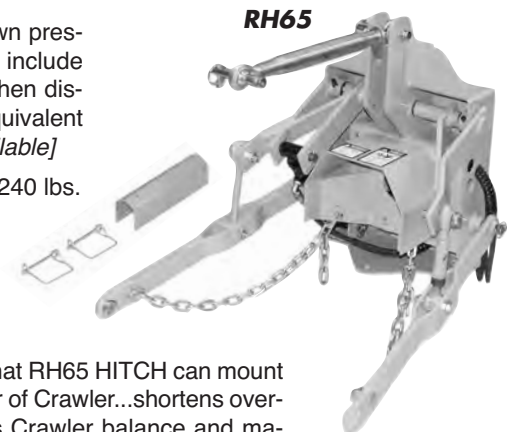

RH20

## RH20 Accessory Kit

Set of shorter "lift arms" and "center link body" so that RH65 HITCH can mount its attachments approximately 8 inches closer to rear of Crawler...shortens overall length of Crawler and attachment and improves Crawler balance and maneuverability. [Not for PTO70 Power Takeoff applications!]

RH20 Accessory Kit ..... 27 lbs.

**NOTE: Attachments for the RH65 REAR HITCH are of the standard Category #1 type and are readily available locally at most farm equipment dealers.**

# MAGNATrac® Attachment Kits



## PTO70 Power Takeoff Kit

Full power hydraulic motor with standard 1-3/8" diameter, six splined shaft. Mounts in "cavity" in RH65 REAR HITCH. Complete with hoses, fittings and all mounting hardware. Develops approximately 19 HP at 540 RPM w/25 HP Engine. *[Factory assembly available].*

**PTO70 Power Takeoff Kit** ..... 24 lbs.

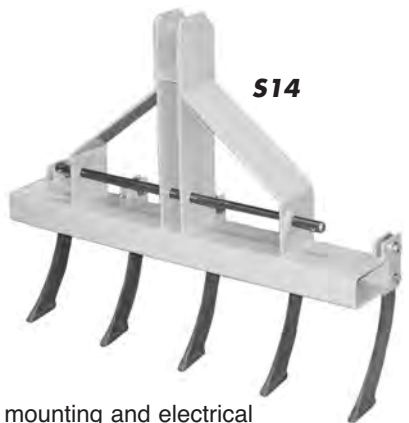

## S14 Scarifier / Ripper Kit

Heavy-duty five tooth Scarifier / Ripper. Five scarifier teeth are interchangeable on heavy-duty mounting frame to create a variety of ripping patterns. Useful for shattering hard, dry soil, compacted driveways, etc.

**S14 Scarifier / Ripper Kit** ..... 115 lbs.

## HC74 Hydraulic Circuit Kit

Standard on MH8000. Complete with hoses, fittings, power beyond plug, rotary valve and all mounting and electrical safety switch hardware. This Hydraulic Circuit is required for operation of PTO70 POWER TAKEOFF (see above) and can also be used for powering NH3A REMOTE AUGER DRIVE or 3rd party attachments...check with factory for proper applications *[Requires factory installation].*

**HC74 Hydraulic Circuit Kit** (not shown) ..... 21 lbs.



## NH3A Remote Auger Kit

Complete hydraulic auger drive assembly which can be mounted to your Loader Bucket or in place of your D108 Backhoe Bucket. Does not require a Rear Hitch or Power Takeoff...Loader and Backhoe can remain in place. Does not include Auger (see below). Requires HL900 [Series] Loader or D108 Backhoe. *[Auger Not Manufactured by C.F. Struck Corp.]*

**NH3A Remote Auger Kit** ..... 160 lbs.

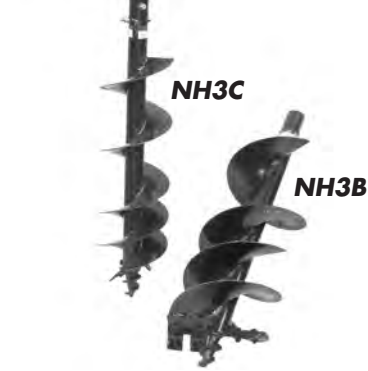

## Augers for NH3A Remote Auger

- NH3B Auger** - 12" dia. cut, alloy steel point and cutting edge, 42" length ..... 50 lbs.
- NH3C Auger** - Same as NH3B (above), but with 9" dia. cut, 42" length ..... 37 lbs.
- NH3D Auger** - 24" auger, perfect for planting small trees, 30" length (not shown) ..... 75 lbs.

## What do I do next?

Here at C.F. Struck Corp we do not believe in high pressure sales. Choosing the crawler that is right for you takes time and planning. We want to do everything we can to help, so tell us what you need.

### #1 I need more information

If you haven't done so already, please ask for our FREE planning kit and introductory DVD. It will have every piece of printed literature we have to offer, and should answer most any question you may have. Make sure and take a look at our website for even more information

[www.StruckCorp.com](http://www.StruckCorp.com)

If you have received our planning kit and your questions still aren't answered move on to #2.

### #2 I have a question

So you have read everything, combed the web site for every piece of information you could find, watched the DVD so many times you have it memorized, and you still have questions.

**Pick up the phone and give us a call or send us an email.**  
**(262) 377 - 3300**  
**info@StruckCorp.com**

Whether you want to know a performance specification, or if it will fit in your garage we'll find the answer.

### #3 I am almost ready to buy

If you've decided which Struck Crawler and attachments you need then we would like to prepare you a FREE quote. This way we double check everything for compatibility and optimum performance. We'll also do a little research and find the best shipping rate for your tractor and location.

It's FREE, and we won't bother you again, unless you ask us to.