

# SCX1500-2

The New World Standard Crawler Crane

## ASIAN ISSUE



# Take A Close Look. The SCX1500-2 Sets New Standards of Higher Crane Productivity And Profitability More Than Ever.

To answer all of demands and requirements from crawler crane users throughout the world, HITACHI SUMITOMO now offers the SCX1500-2, the New World Standard Crane of 150t class machine. Developed along the concept themes of "simple, refined and reliable", the SCX1500-2 offers new levels of safety, operability, durability and ease of maintenance.

## Advanced clutchless multiple wet-disk brake is well designed, and ensures continuous heavy-duty operation.

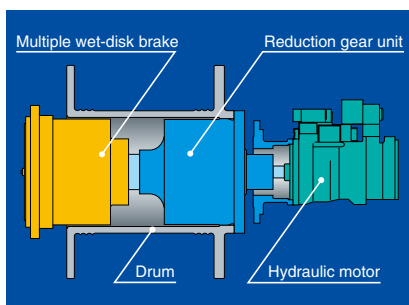

The winch uses a multiple wet-disk brake, and a forced-oil cooling system is designed to sustain brake performance even in continuous heavy-duty operations, such as hammer grabbing. This brake system is designed to provide reliability while requiring no maintenance. Also, a newly developed mechanism is used on this brake design to reduce drag resistance and it realizes a smooth friction-off between discs while a high-viscosity hydraulic oil is used as standard, contributing to longer lift of hydraulic pumps and motors.



## Powerful winch drum with bigger line pull.

The SCX1500-2 is really a versatile machine, and certainly performs not only liftcrane/luffing towercrane works but also duty cycle works under the applications of clamshell, hammer grab and so on with bigger line pull of 196kN <20t> as maximum with 26 mm dia. cable. In addition, by employing a specially-tailored power increase control, the engine always maximizes its output under any load condition in whole range of engine rpm.

## Optional third drum.

A third drum is optionally available under the same specifications as that of two main operating drums, and it accordingly enables to efficiently perform heavy duty works under an 196kN <20t> line pull.

## New negative brake system much reduces operator fatigue and enhances safety.

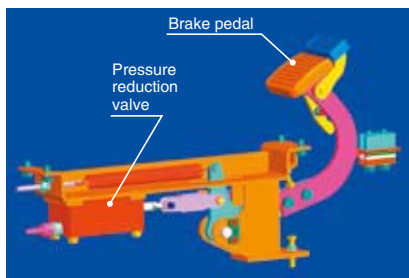

With a new negative brake of spring-applied/power hydraulically-released type applying dynamic hydraulic pressure for its release control, an effective braking can be done under an extreme light foot pedaling, and it accordingly results in greatly reducing operator fatigue, especially

during winch free-fall operation under duty cycle applications. Further, the use of negative brake system maintains a high level of brake safety even if a hydraulic pressure drop in the circuit happens.

## An aluminum-make oil cooler.

For not only corrosion resistance but also high cooling efficiency, an aluminum-make oil cooler is provided in front of engine radiator.









Linkage mechanism



### A high operation ease with specially-tailored EPC system.

Thanks to unique EPC system, an easy-precise-minute control of engine rpm and pump discharge from min. thru max. is actually possible at the same time by simply twisting the grip.

### Cab large sliding door.

For an easy entry and exit to and from the cab, a slewing-link type cab large sliding door is well designed.

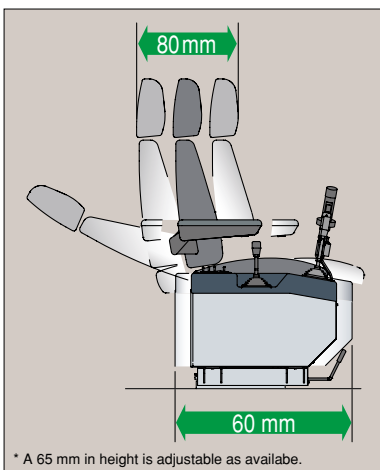

### Optional air-conditioner of outside-airintake type.

For good air-conditioning with fresh air, an outside-airintake type air-conditioner is optionally available.

### A good slewing speed control design.

Max. slewing speed can be steplessly controlled thru an easy dialing for smooth slewing for all kinds of work and operations like "higher hook hoisting and lower slewing speed" in a high lift working.



### Armchair control station with drum rotation sensors.

An armchair control station is provided for a good, easy and comfortable operation. In addition, armchair control levers of two main and boom hoist drums each fit the drum rotation sensor to let operator sense a drum rotation speed decrease gradually according to the extent of the load applied to the hoist cable, and it results in more safety lifting work, especially in blind condition.

### Slidable control station and operator seat.

To set most of suitable operator position, both right- and left-hand control stations are designed to simultaneously slide 60 mm back and forth together with operator seat, and operator seat is able to slide 80 mm independently too.

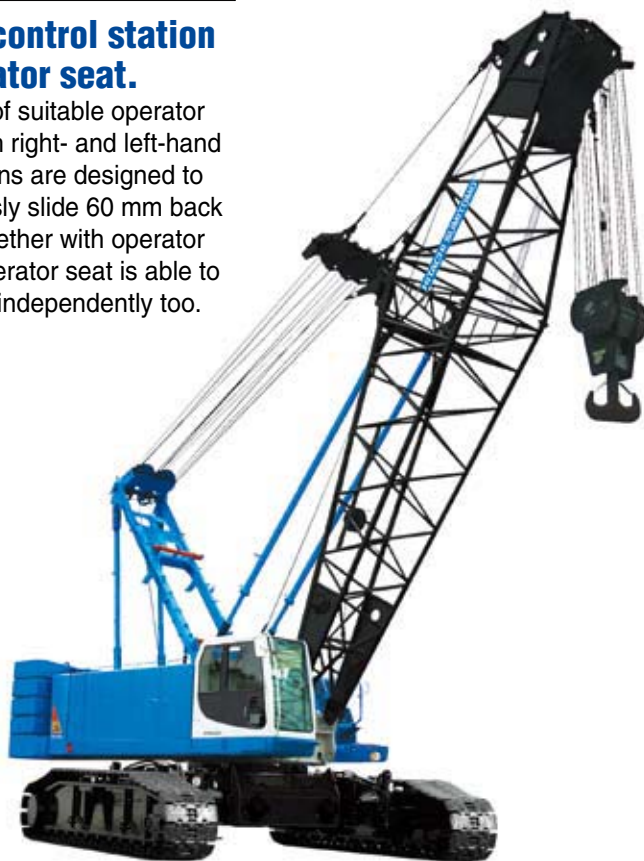

### Simplified instrument panel.

For operator convenience, all of switches and controllers are gathered in a left-handed instrument panel.





The New World Standard **SCX1500-2**

# Job-Proven Controllability and Operator Comfort

**Newly designed cab with increased visibility.**

Functional layout of controls, including armchair control levers, improves visibility -- forward, rearward and sideward. And, it accordingly results in enhancing operating ease under operator comfort with a natural position.





# Pays a keen attention to safety, transport and environment too.

## Safety



### Newly-designed Load Moment Indicator.

An easy-to-read LCD graphic display panel is well designed and a reflection-less display panel is provided on a new Load Moment Indicator (LMI) with setting ease of viewing angle. In addition, no zero-point adjustment, and data input thru interface counter-indication/message on display panel are available for easier and certain setting of operating conditions and LMI functions. Of course, "present lifting load", "rated load", "load ratio", "working radius", "boom angle", "engine rpm" and so on are indicated on the LMI display panel. Further, displayed picture and menu selection can be easily set up by panel switch in accordance with operation situation and condition.

### LMI automatically sets front-end att. erection mode with letter message.



In the range out of crane working area, the LMI display panel automatically

indicates "Now, out of crane working range" with a rigging instruction, and it is available to lift front-end att. off ground without the influence of M/L safety functions, and, after front-end att. is lifted over the range of crane working area, LMI safety function gets back automatically for safe erection work.



### Boom speed slowdown function.

This function is available just before automatic stopping at both upper and lower side limits of boom angle to prevent a shock even though control lever is still at hoisting/lowering position. This function is also available when over-loading.



### Automatic drum pawl locking device.

On boom hoist drum, it is designed to automatically lock and release drum pawl when control lever just returns to neutral position, and just actuates.

### Optional lifting height indication function.

For more safe lifting work, especially in blind condition, it is optionally available to indicate the lifting height above ground or depth below ground on display panel of LMI.



### Independent lever lock.

Each lever can be locked independently to prevent absent-minded misoperation.

### Slewing/travel alarms.

These alarms alert work crew around the machine when slewing and/or traveling to keep clear for safety.



### **Fool proof shut-off system.**

To insure safety when the operator leaves the cab, a main hydraulic shut-off switch is located in the cab exit to deactivate and lock the hydraulic system.

## **Mobility & Transportability**



### **Counterweight with horizontally-split design.**

It is able to load boom extension(s) onto counterweight when transport.

And, the reversible stack is possible to reduce the time for disassembling/assembling works.

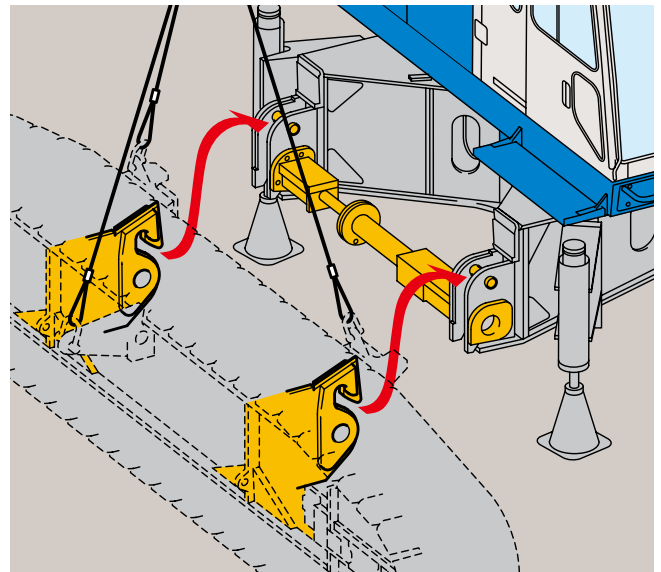

### **An assembling ease of crawler side frames.**

Thanks to "hook-on design" with hydraulic removal jointpins, crawler side frames can be easily assembled and disassembled on and from lower frame, and it accordingly result in a time saving task.

## **Environment**

The engine meets current EU Emission Regulations for Off-Road Diesel Engine-Stage 3, and Japanese Emission Standard for Diesel Construction Equipment-Stage 3, and the SCX1500-2 clears low noise levels as defined by Ministry of Land, Infrastructure and Transport of Japan under the new noise measuring methods regulated by ISO.



# SCX1500-2

## GENERAL DIMENSIONS

Unit : mm

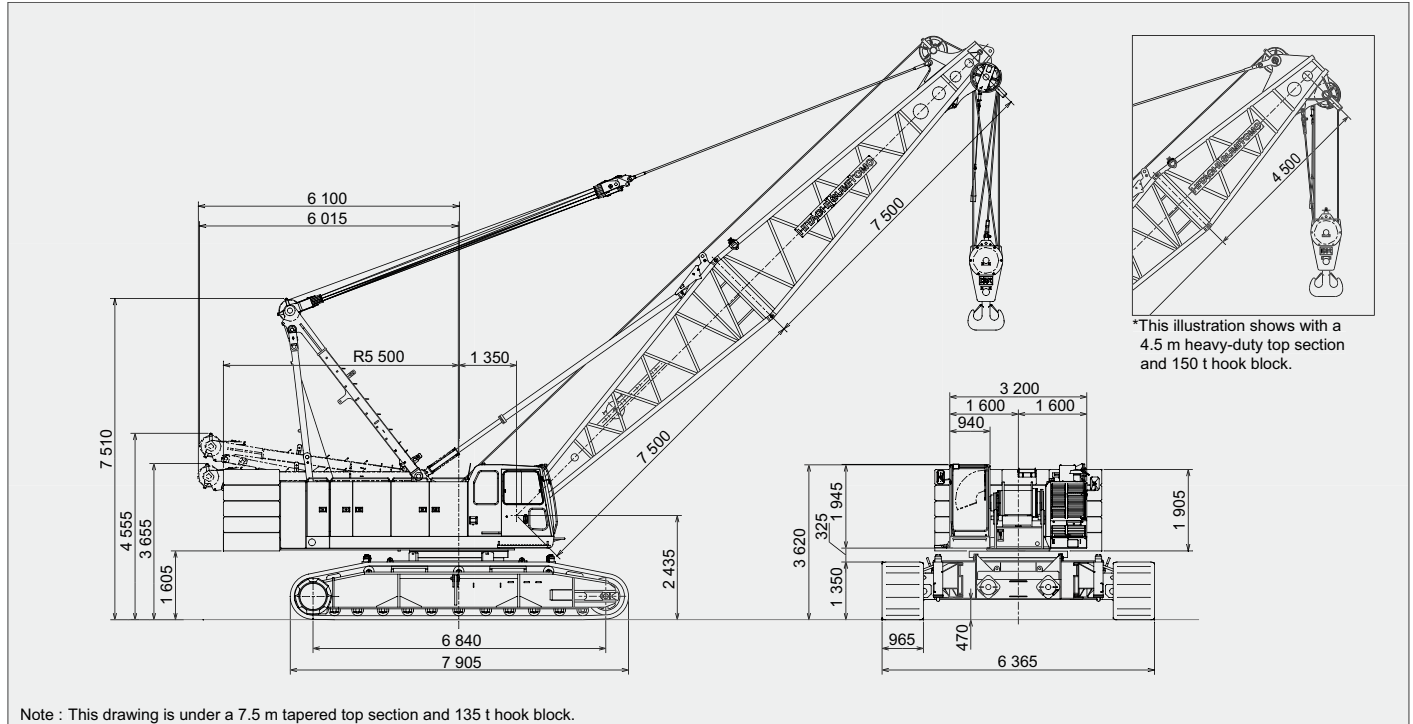

## SPECIFICATIONS

		Liftcrane application	Clamshell application
Max. lifting capacity <sup>(*1)</sup>	t × m	150 × 4.1	—
Basic boom length	m	12 or 15	15
Max. boom length	m	75	27
Fly jib length	m	10 ~ 28	—
Boom + fly jib length	m	60 + 28 / 63 + 22	—
Tower length	m	—	—
Tower jib length	m	—	—
Tower + jib length	m	—	—
Rope line speeds <sup>(*2)</sup>	Front main drum	m / min	110
	Rear main drum	m / min	110
	Boom hoist drum	m / min	46
Slewing speed	min <sup>-1</sup>	1.9	1.9
Travel speed	high/low <sup>(*3)</sup>	1.7 / 1.0	1.7 / 1.0
Gradeability	% (°)	30 (17)	30 (17)
Engine	Make & model	Isuzu 6HK1X	Isuzu 6HK1X
	Rated output	kW / min <sup>-1</sup>	212 / 2 000
Ground contact pressure	kPa	96	90.4
Operating weight	t	129 ( w / 15 m basic boom and 135 t hook block )	121.9 ( w / 15m boom and 2.5m <sup>3</sup> / 5.5t clamshell bucket )

- Notes : 1. An 150 t nominal lift is only available under 12 m basic boom (\*1).  
 2. These figures are based on drum first layer and rated engine rpm with no load, and vary under load and operating conditions (\*2).  
 3. Travel speed is based on flat, level and firm supporting surface, and under the conditions that no load must be applied and front-end att. must be 12 / 15 m basic boom (\*3).  
 4. The specifications for luffing towercrane application to be advised later.

We are constantly improving our products and therefore reserve the right to change designs and specifications without notice.  
 Units in this catalog are shown under International System of Unit; the figures in parenthesis are under Gravitational System of Units as old one.  
 Illustrations may include optional equipment and accessories, and may not include all standard equipment.

Address inquires to :

## Hitachi Sumitomo Heavy Industries Construction Crane Co., Ltd.

9-3, Higashi Ueno 6-chome, Taito-ku, Tokyo 110-0015, Japan  
 Phone: 81-3-3845-1387 Facsimile: 81-3-3845-1394  
<http://www.hsc-crane.com>